



Chipsmall Limited consists of a professional team with an average of over 10 year of expertise in the distribution of electronic components. Based in Hongkong, we have already established firm and mutual-benefit business relationships with customers from,Europe,America and south Asia,supplying obsolete and hard-to-find components to meet their specific needs.

With the principle of "Quality Parts,Customers Priority,Honest Operation,and Considerate Service",our business mainly focus on the distribution of electronic components. Line cards we deal with include Microchip,ALPS,ROHM,Xilinx,Pulse,ON,Everlight and Freescale. Main products comprise IC,Modules,Potentiometer,IC Socket,Relay,Connector.Our parts cover such applications as commercial,industrial, and automotives areas.

We are looking forward to setting up business relationship with you and hope to provide you with the best service and solution. Let us make a better world for our industry!



Contact us

Tel: +86-755-8981 8866 Fax: +86-755-8427 6832

Email & Skype: info@chipsmall.com Web: www.chipsmall.com

Address: A1208, Overseas Decoration Building, #122 Zhenhua RD., Futian, Shenzhen, China



UG300: Si5332-8EX-EVB User's Guide

The Si5332-8EX-EVB is used for evaluating the Si5332 Low Jitter Any-Frequency Clock Generator. The Si5332 uses the patented Multisynth™ technology to generate up to twelve independent clock frequencies each with 0 ppm synthesis error. The Si5332-8EX-EVB has three independent input clocks. The Si5332-8EX-EVB can be controlled and configured using the Clock Builder Pro™ (CB Pro™) software tool.

EVB FEATURES

- Powered from USB port or external power supply.
- Onboard 25 MHz XTAL allows free-run mode of operation on the Si5332 or up to 2 input clocks for synchronous clocking.
- CBPro™ GUI programmable VDD supply allows device to operate from 3.3, 2.5, or 1.8 V.
- CBPro GUI programmable VDDO supplies allow each of the 10 outputs to have its own power supply voltage selectable from 3.3, 2.5, or 1.8 V.
- CBPro GUI-controlled voltage, current, and power measurements of VDD and all VDDO supplies.
- SMA connectors for input and output clocks.

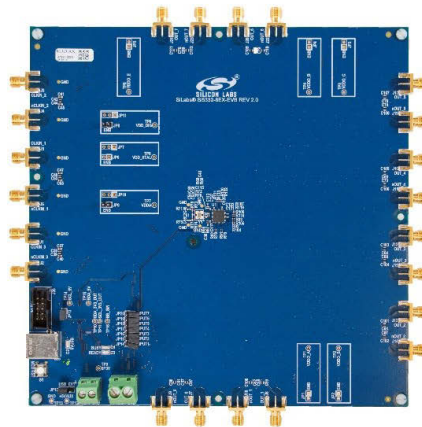

Table of Contents

- 1. Functional Block Diagram 3
- 2. Si5332 CBPro™ 4
- 3. Si5332-8EX-EVB Schematics 5
- 4. Si5332 CBPro™ EVB GUI 6
- 5. Installing ClockBuilderPro (CBPro) Desktop Software 7

1. Functional Block Diagram

Below is a functional block diagram of the Si5332-8EX-EVB. This EVB can be connected to a PC via the main USB connector for programming, control and monitoring. See section “2. Quick start” or section “7. Installing CBPro Desktop Software” for more information.

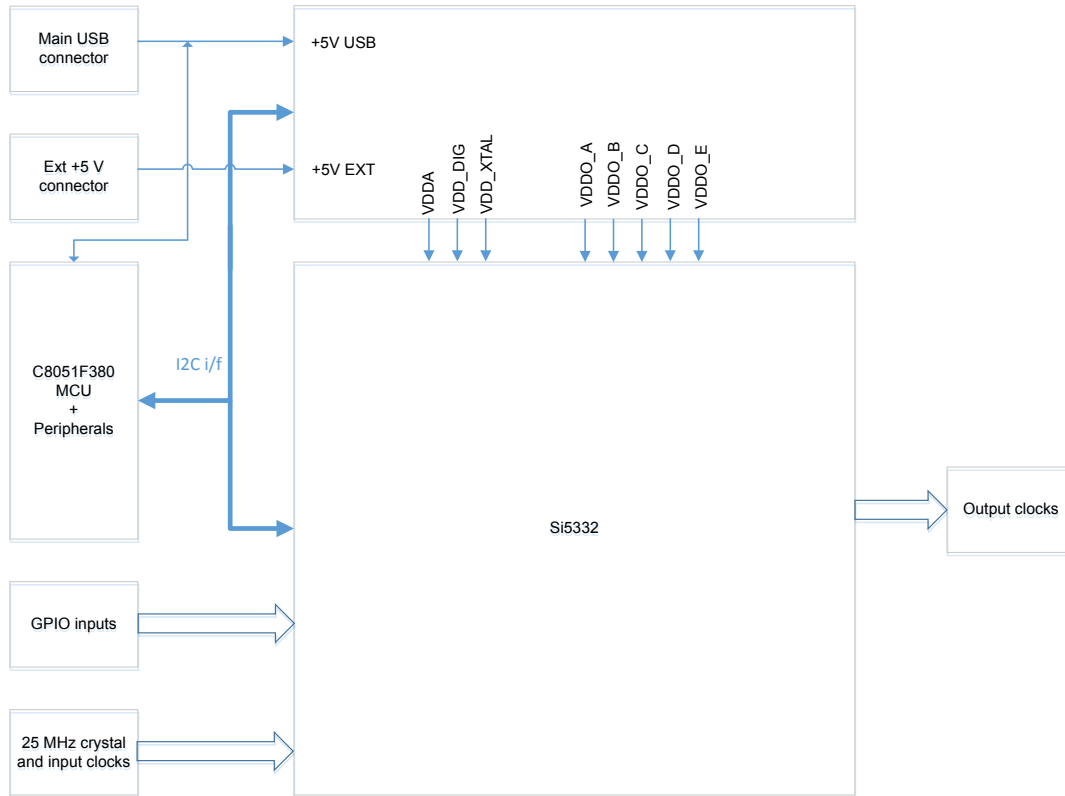

Figure 1.1. Si5332-8EX-EVB Functional Block Diagram

2. Si5332 CBPro™

The Si5332 is intended to be part of the CBPro software and this initial software release “showcases” that trait. This software contains:

1. An EVB GUI that communicates and controls the EVB by allowing the user to set VDD supplies
2. The ability to modify frequency plan (from the starting point CBPro file provided with this limited release) from an existing CBPro file.

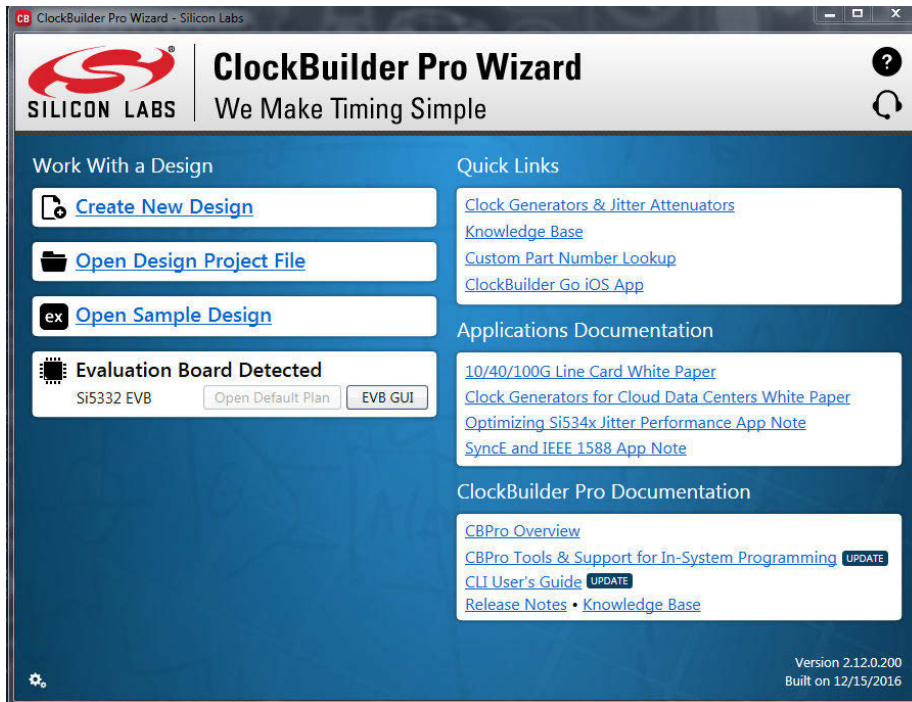

Figure 2.1. CBPro Start Screen

3. Si5332-8EX-EVB Schematics

The schematic and layout files are provided in the here: [schematics and layouts](#).

Please review the files, especially the DUT page in order to get familiar with using the EVB through CBPro™.

4. Si5332 CBPro™ EVB GUI

The EVB GUI can be used to communicate the part for register access:

The first page shows the board's identity.

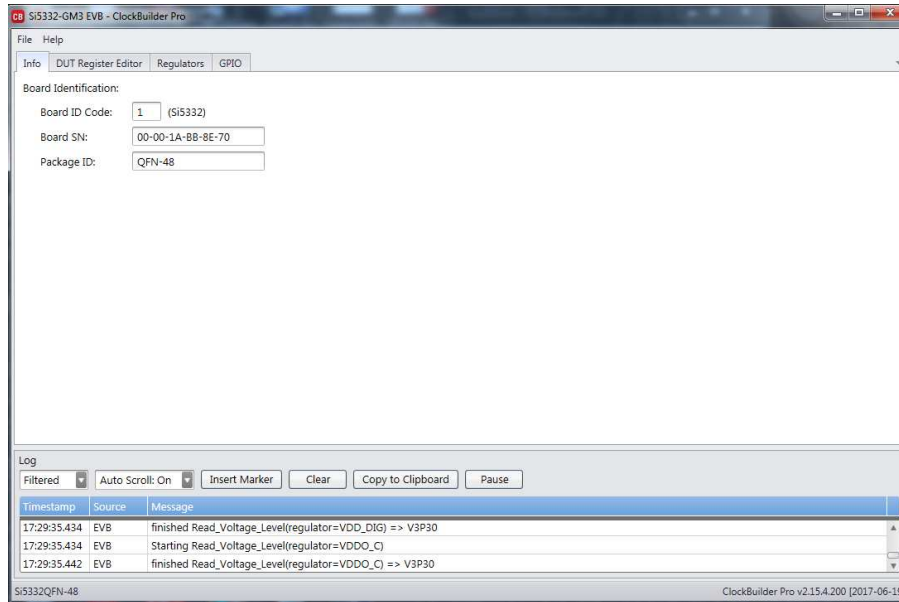

Figure 4.1. Board ID Page

The other pages for for register access, VDD control, and GPIO control.

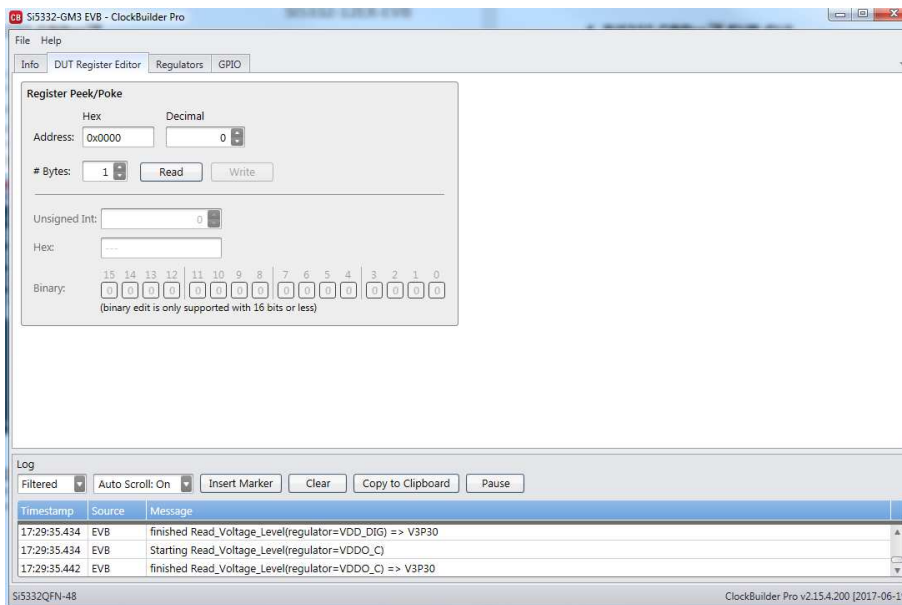
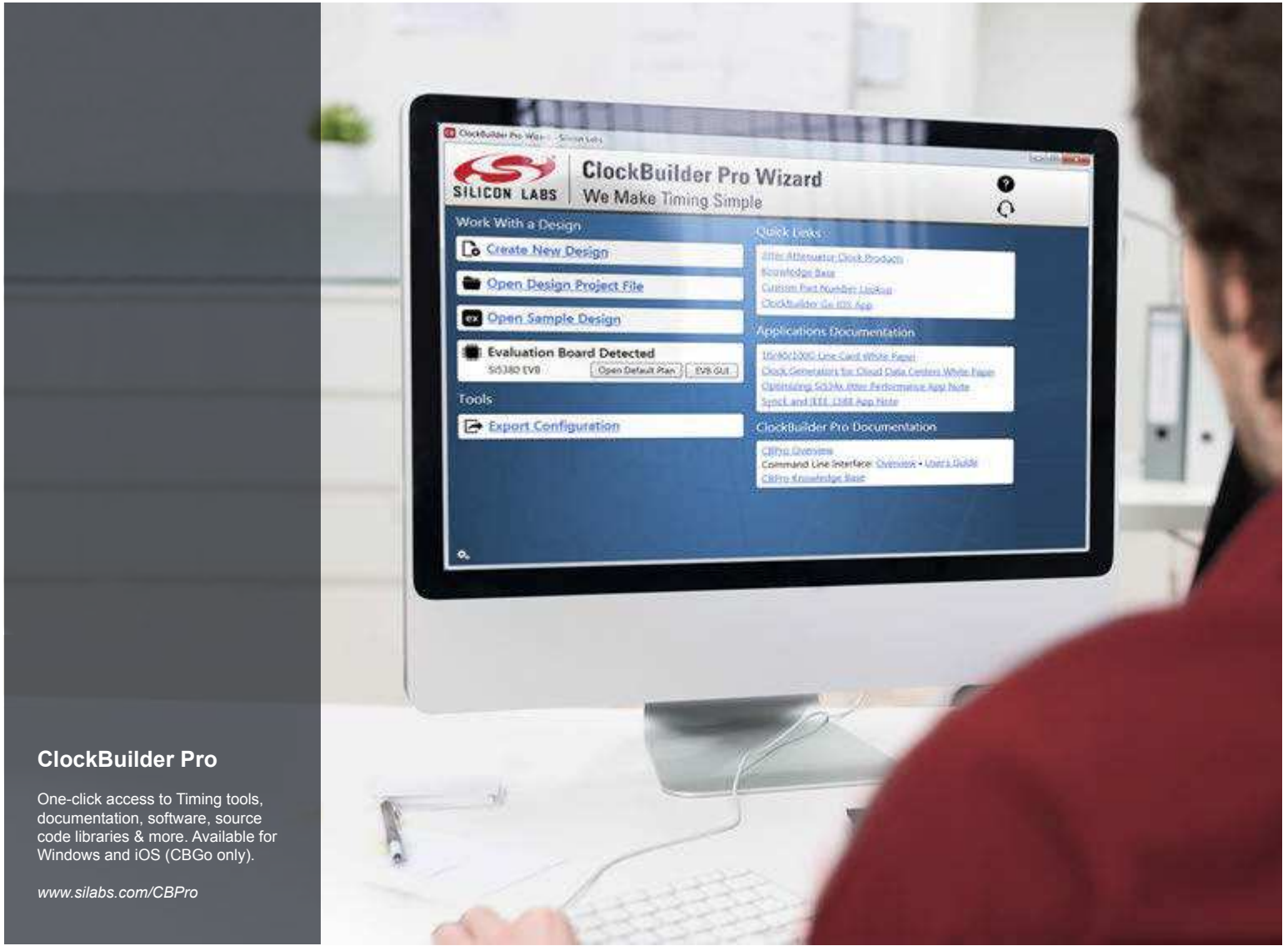

Figure 4.2. Register Access

5. Installing ClockBuilderPro (CBPro) Desktop Software

To install the CBOPro software on any **Windows 7** (or above) PC:

Go to <https://www.silabs.com/products/development-tools/software/clockbuilder-pro-software> and download ClockBuilderPro software. Both installation instructions and User's Guide for ClockBuilderPro can be found at this link. Please follow the instructions as indicated.



ClockBuilder Pro

One-click access to Timing tools, documentation, software, source code libraries & more. Available for Windows and iOS (CBGo only).

www.silabs.com/CBPro



Timing Portfolio
www.silabs.com/timing



SW/HW
www.silabs.com/CBPro



Quality
www.silabs.com/quality



Support and Community
community.silabs.com

Disclaimer

Silicon Labs intends to provide customers with the latest, accurate, and in-depth documentation of all peripherals and modules available for system and software implementers using or intending to use the Silicon Labs products. Characterization data, available modules and peripherals, memory sizes and memory addresses refer to each specific device, and "Typical" parameters provided can and do vary in different applications. Application examples described herein are for illustrative purposes only. Silicon Labs reserves the right to make changes without further notice and limitation to product information, specifications, and descriptions herein, and does not give warranties as to the accuracy or completeness of the included information. Silicon Labs shall have no liability for the consequences of use of the information supplied herein. This document does not imply or express copyright licenses granted hereunder to design or fabricate any integrated circuits. The products are not designed or authorized to be used within any Life Support System without the specific written consent of Silicon Labs. A "Life Support System" is any product or system intended to support or sustain life and/or health, which, if it fails, can be reasonably expected to result in significant personal injury or death. Silicon Labs products are not designed or authorized for military applications. Silicon Labs products shall under no circumstances be used in weapons of mass destruction including (but not limited to) nuclear, biological or chemical weapons, or missiles capable of delivering such weapons.

Trademark Information

Silicon Laboratories Inc.®, Silicon Laboratories®, Silicon Labs®, SiLabs® and the Silicon Labs logo®, Bluegiga®, Bluegiga Logo®, Clockbuilder®, CMEMS®, DSPLL®, EFM®, EFM32®, EFR, Ember®, Energy Micro, Energy Micro logo and combinations thereof, "the world's most energy friendly microcontrollers", Ember®, EZLink®, EZRadio®, EZRadioPRO®, Gecko®, ISOModem®, Micrium, Precision32®, ProSLIC®, Simplicity Studio®, SiPHY®, Telegesis, the Telegesis Logo®, USBXpress®, Zentri and others are trademarks or registered trademarks of Silicon Labs. ARM, CORTEX, Cortex-M3 and THUMB are trademarks or registered trademarks of ARM Holdings. Keil is a registered trademark of ARM Limited. All other products or brand names mentioned herein are trademarks of their respective holders.



Silicon Laboratories Inc.
400 West Cesar Chavez
Austin, TX 78701