



Chipsmall Limited consists of a professional team with an average of over 10 year of expertise in the distribution of electronic components. Based in Hongkong, we have already established firm and mutual-benefit business relationships with customers from,Europe,America and south Asia,supplying obsolete and hard-to-find components to meet their specific needs.

With the principle of “Quality Parts,Customers Priority,Honest Operation,and Considerate Service”,our business mainly focus on the distribution of electronic components. Line cards we deal with include Microchip,ALPS,ROHM,Xilinx,Pulse,ON,Everlight and Freescale. Main products comprise IC,Modules,Potentiometer,IC Socket,Relay,Connector.Our parts cover such applications as commercial,industrial, and automotives areas.

We are looking forward to setting up business relationship with you and hope to provide you with the best service and solution. Let us make a better world for our industry!



Contact us

Tel: +86-755-8981 8866 Fax: +86-755-8427 6832

Email & Skype: info@chipsmall.com Web: www.chipsmall.com

Address: A1208, Overseas Decoration Building, #122 Zhenhua RD., Futian, Shenzhen, China



Si5350/51 20-QFN EVALUATION BOARD USER'S GUIDE

Description

The Si535x-20QFN-EVB is used for evaluating the Si5350/51 any-frequency, <125 MHz CMOS clock generator + VCXO.

Features

- Fully-powered from a single USB port
- Onboard 27 MHz crystal for asynchronous operation
- SMA and test point hook for interfacing to an external clock reference
- Jumper-selectable VDD and VDDOx allows device to operate at 2.5 or 3.3 V
- Voltage supply jumpers provide easy access for use with external supplies

Functional Block Diagram

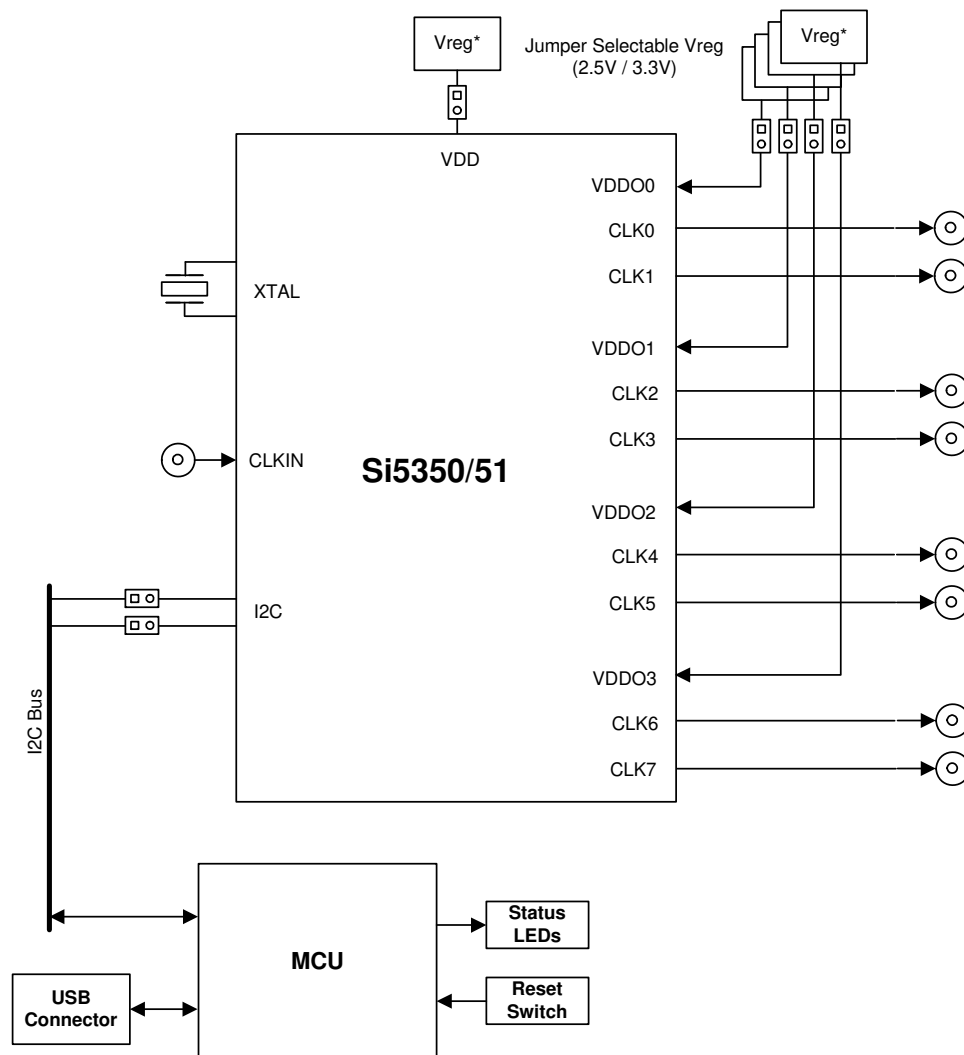

Si535x-20QFN-EVB

1. Functional Block Diagram

Figure 1 highlights the main features of the EVB. The onboard MCU is responsible for programming the Si535x timing IC, measuring the device's current consumption reported in the ClockBuilder™ Desktop, managing power, and controlling status LEDs. VDD and VDDO jumpers allow the option of choosing between 2.5 V and 3.3 V or powering the device with external supplies (see “2. Jumpers” for details). I²C jumpers allow the Si535x to be disconnected from the I²C bus, allowing external control from another I²C master.

The device can run in stand-alone asynchronous mode using the onboard 27 MHz XTAL (Y1), or it can be synchronized to an external clock using the CLKIN SMA connector or TP39/TP40.

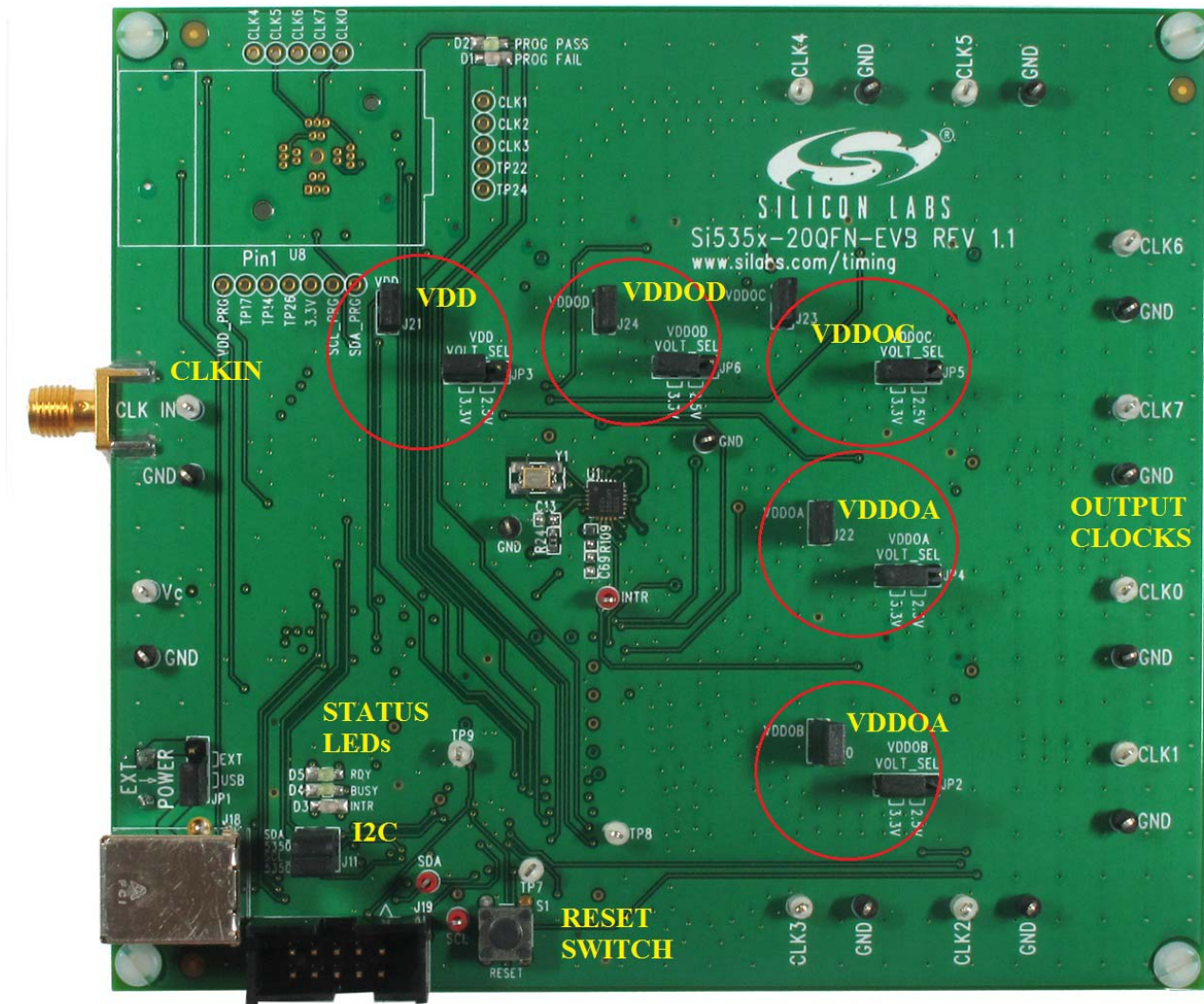

Figure 1. EVB Features

2. Jumpers

The following jumpers are available on the evaluation board:

- **VDD**—Connects the Si5350/51 pin to the VDD voltage regulator (normally installed).
- **VDD VOLT_SEL**—Allows user to select a VDD voltage of 2.5 V or 3.3 V (default 3.3 V).
- **VDDOA**—Connects the Si5350/51 pin to the VDDOA voltage regulator (normally installed).
- **VDDOA VOLT_SEL**—Allows user to select a VDDOA voltage of 2.5 V or 3.3 V (default 3.3 V).
- **VDDOB**—Connects the Si5350/51 pin to the VDDOB voltage regulator (normally installed).
- **VDDOB VOLT_SEL**—Allows user to select a VDDOB voltage of 2.5 V or 3.3 V (default 3.3 V).
- **VDDOC**—Connects the Si5350/51 pin to the VDDOC voltage regulator (normally installed).
- **VDDOC VOLT_SEL**—Allows user to select a VDDOC voltage of 2.5 V or 3.3 V (default 3.3 V).
- **VDDOD**—Connects the Si5350/51 pin to the VDDOD voltage regulator (normally installed).
- **VDDOD VOLT_SEL**—Allows user to select a VDDOD voltage of 2.5 V or 3.3 V (default 3.3 V).
- **SCL**—Connects the Si5350/51 SCL pin to the I²C bus from the MCU. Removing the jumper breaks the connection to the MCU and allows the user to feed in an external I²C signal to the device.
- **SDA**—Connects the Si5350/51 SDA pin to the I²C bus from the MCU. Removing the jumper breaks the connection to the MCU and allows the user to feed in an external I²C signal to the device.
- **EXP POWER**—Allows user to select between 5 V USB supply and 5 V external supply on J17. See Figure 1 for jumper locations.

3. Status LEDs

There are three status LEDs on the evaluation board:

- **RDY (Green)**—Indicates that the EVB is operating normally. This LED should always be on.
- **BUSY (Green)**—Indicates that the on-board MCU is communicating with the device and/or the USB host.
- **INTR (Red)**—Indicates device or EVB fault condition (also on when DUT hasn't been programmed).

4. Clock Inputs

The EVB can operate in asynchronous mode using the onboard 27 MHz crystal, synchronous mode using an external CMOS clock source, or both modes if both PLLs in the device are utilized. An SMA connector is provided to interface an external clock source to CLKIN. Additionally, CLKIN can be applied using the test hooks TP39/TP49.

Si535x-20QFN-EVB

5. Clock Outputs

Outputs must be measured with a high-impedance scope probe. A ground test point is provided 0.3" away from each clock output for ideal measurement. Most scope probes have a ground clip attached to the probe with a 3–6" length of cable. Use of these ground clips is not recommended since the ground reference is electrically far from the probe tip, especially for frequencies greater than a few Megahertz. Figure 2 shows the ideal measurement practice. Note that the probe ground closest to the probe tip is used as the reference.

Clock voltage levels can be 2.5 or 3.3 V depending on the VDDOx VOLT_SEL jumper selection.

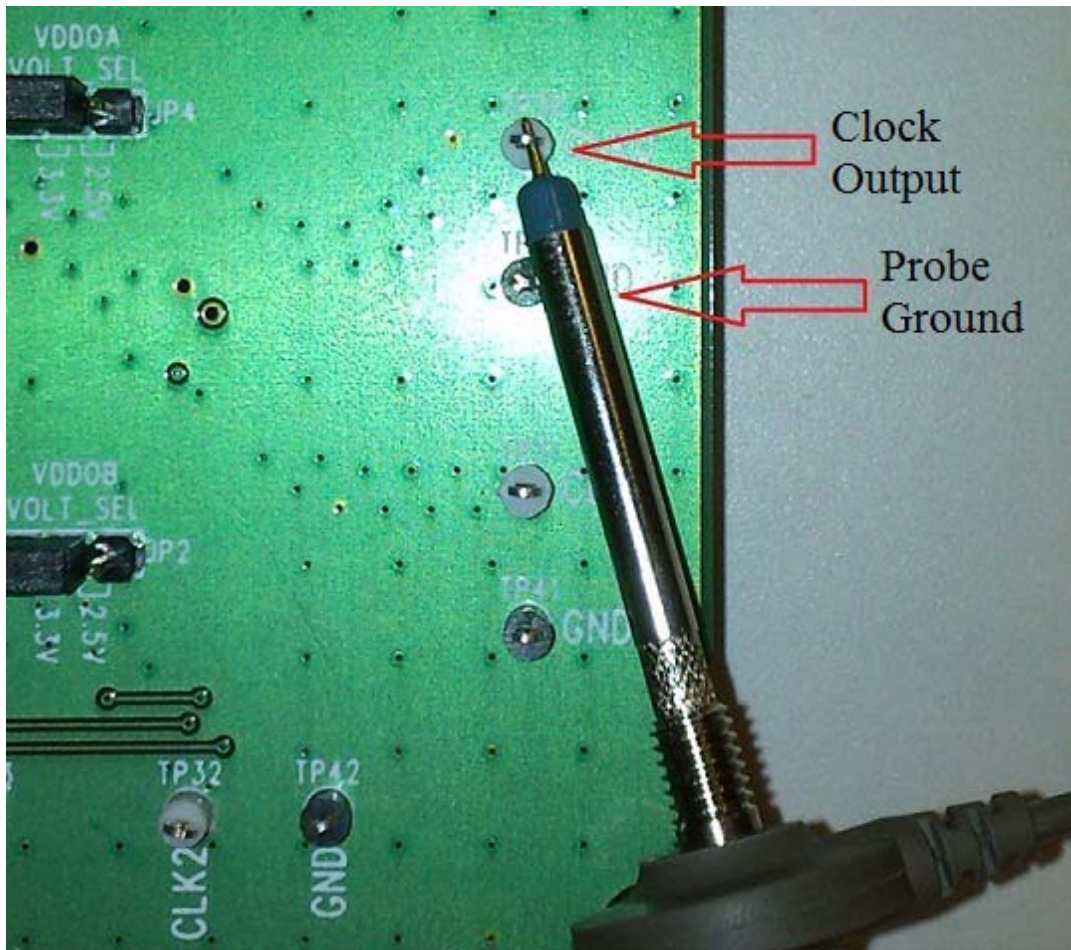

Figure 2. Measuring Output

6. Software Guide

The evaluation kit includes a software toolset called ClockBuilder Desktop - Si5350/51, consisting of two applications:

- **ClockBuilder Desktop**—Used to set up and evaluate the part and to save custom register map files.
- **Register Programmer**—Used to program individual registers on the evaluation board DUT.

6.1. Quick Start

1. Install the ClockBuilder™ Desktop software and driver (assumes that Microsoft .NET Framework 1.1 is already installed).
2. Connect a USB cable from the EVB to the PC.
3. Leave the jumpers as installed from the factory, and launch the software by clicking on Start → Programs → Silicon Laboratories → ClockBuilder Desktop. Click on one of the shortcuts in the group.

6.2. ClockBuilder Desktop Software Installation

The following sections describe how to install and use the software. There is a readme.txt file with the installation files as well as a software user guide installed with the software.

6.2.1. System Requirements

- Microsoft Windows® 2000, XP, Vista, 7
- USB 2.0
- 3 MB of free hard drive space
- 1024 x 768 screen resolution or greater
- Microsoft .NET Framework 1.1
- USBXpress 3.1.1 driver

Note: USBXpress 3.1.1 driver is provided and installed with the software. Newer or older versions of USBXpress available from other EVB kits or online have not been tested with this software.

6.2.2. Microsoft .NET Framework Installation

The Microsoft .NET Framework is required before installing and running the software. Details and installation information about the .NET Framework are available via a shortcut in the NETFramework directory or at the following web site:

www.microsoft.com/downloads/details.aspx?FamilyId=262D25E3-F589-4842-8157-034D1E7CF3A3&displaylang=en

There are multiple versions of the .NET Framework available from Microsoft, and they can be installed side-by-side on the same computer. The software requires Version 1.1 but can run under other versions. Contact your system administrator for more details.

6.2.3. ClockBuilder Desktop Software Installation

The ClockBuilder Desktop Software is installed from the ClockBuilderDesktopSwInstall.exe file.

1. Double-click the install file to start the wizard.
2. Follow the wizard instructions to complete the installation for both the software and the driver. Use the default installation location for best results.
3. After the installation is complete, click on Start → Programs → Silicon Laboratories → ClockBuilder Desktop Software. Select one of the items in the menu including the User Guide to get more details on how to run the software.

6.2.4. ClockBuilder Desktop Software Uninstall Instructions

Close all the programs and help files before running the uninstaller to ensure complete removal of the software. To uninstall the software, use the Add and Remove Programs utility in the Control Panel or click Start → Programs → Silicon Laboratories → ClockBuilder Desktop → Uninstaller

Note: The driver software must be uninstalled separately.

7. Si535X-20QFN-EVB Schematics

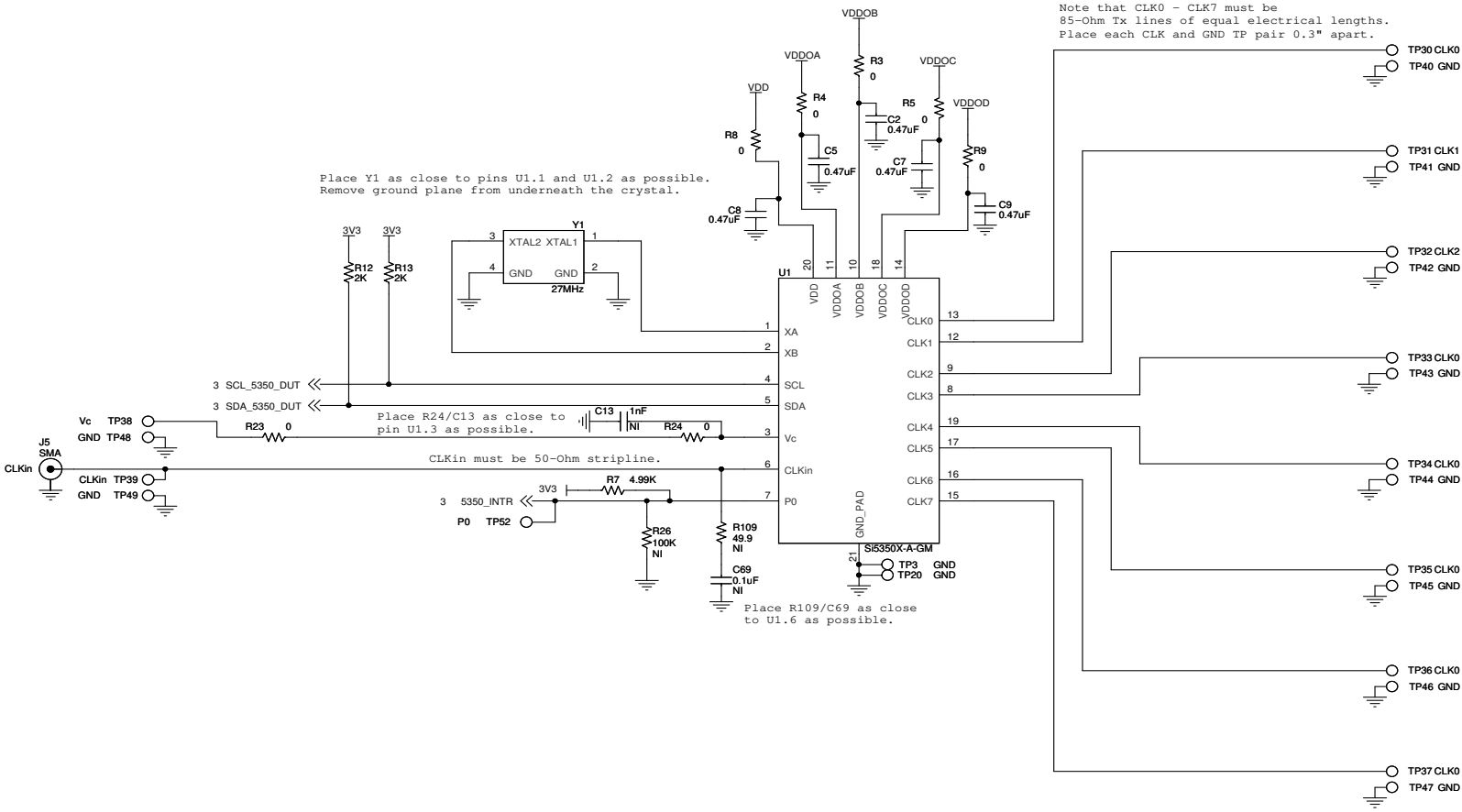

Figure 3. Si5350/51 Main

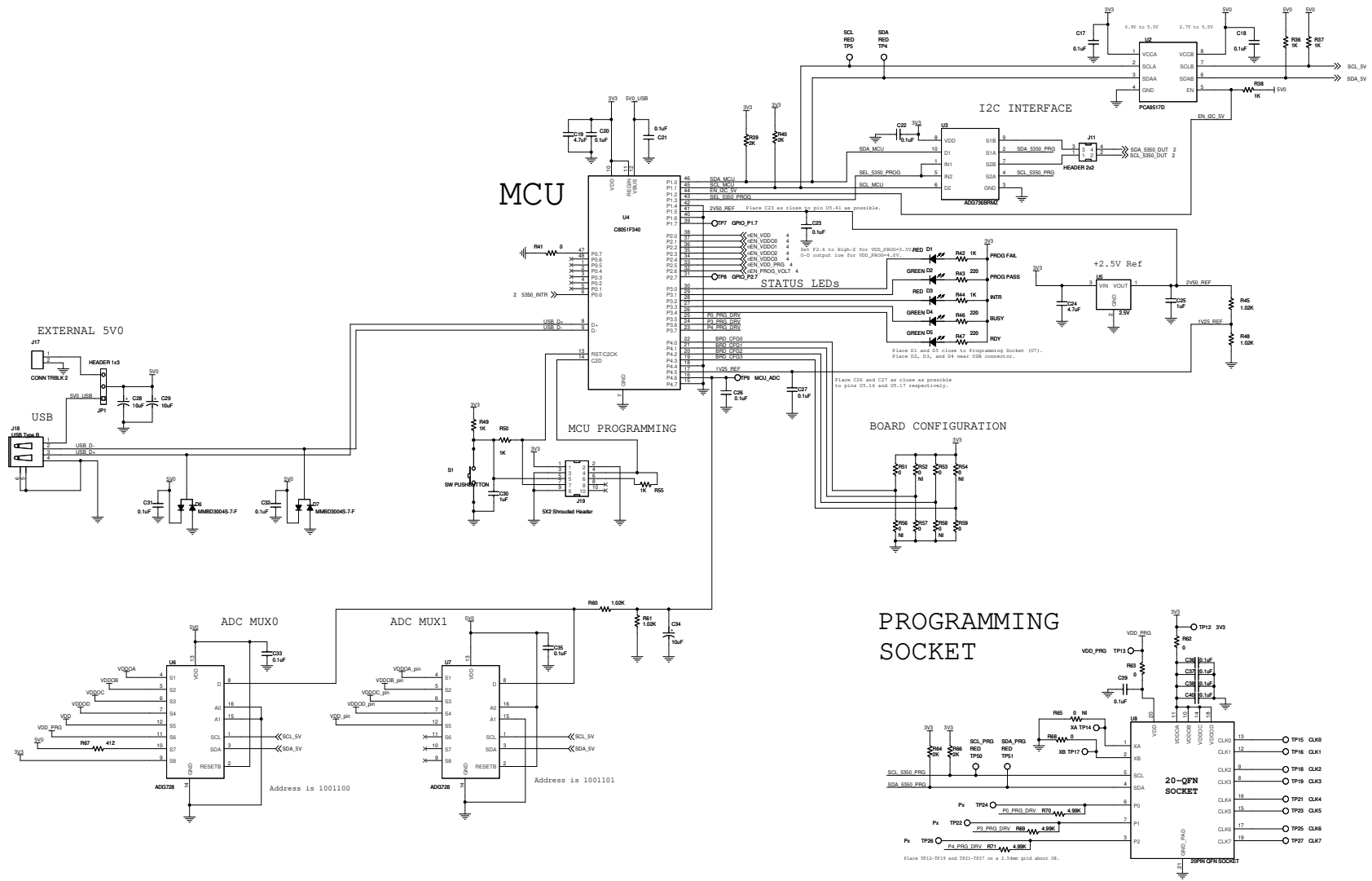

Figure 4. MCU and Programming Socket

Power Supplies

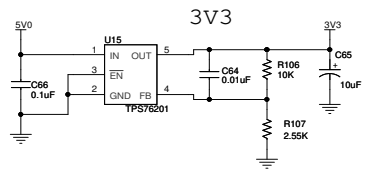
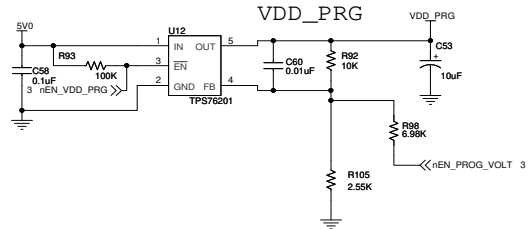
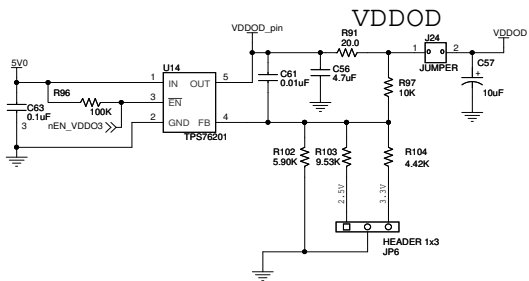
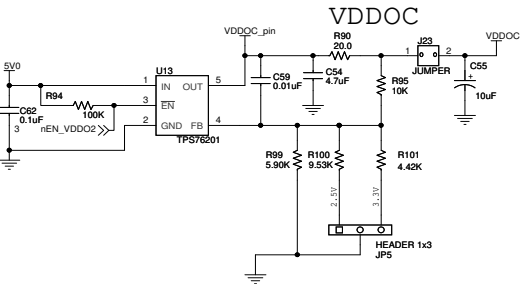
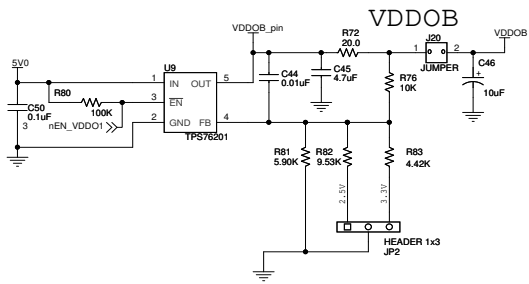
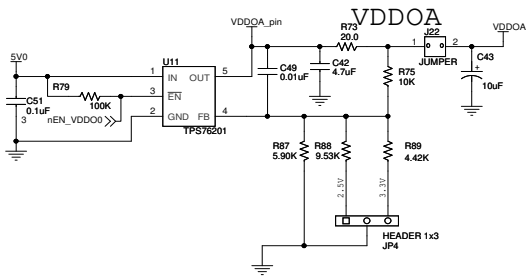
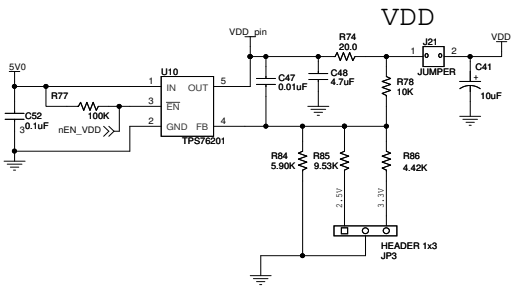

Figure 5. Power Supplies

8. Bill of Materials

Table 1. Si535x Bill of Materials

Item	Qty	Reference	Value	Manufacturer	Part Number
1	5	C2,C5,C7,C8,C9	0.1 μ F	Venkel	C0402X5R100-104K
2	1	C13	1 nF	Venkel	C0603X7R101-102K
3	17	C17,C18,C20, C21,C22,C23,C26, C27,C31,C32,C33, C35,C36,C37,C38, C39,C40	0.1 μ F	Venkel	C0402X7R100-104K
4	7	C19,C24,C42,C45, C48,C54,C56	4.7 μ F	Venkel	C1206X7R100-475M
5	2	C25,C30	1 μ F	Venkel	C1206X7R250-105K
6	10	C28,C29,C34,C41, C43,C46,C53,C55, C57,C65	10 μ F	Kemet	B45196H5106M309
7	7	C44,C47,C49,C59, C60,C61,C64	0.01 μ F	Venkel	C0603X7R160-103M
8	7	C50,C51,C52,C58, C62,C63,C66	0.1 μ F	Venkel	C0603X7R100-104M
9	1	C69	0.1 μ F	Venkel	C0603X7R100-104M
10	2	D1,D3	RED	Panasonic	LN1271RAL
11	3	D2,D4,D5	GREEN	Panasonic	LN1371G
12	2	D6,D7	MMBD3004S-7-F	Diodes Inc.	MMBD3004S-7-F
13	6	JP1,JP2,JP3,JP4, JP5,JP6	HEADER 1x3	Samtec	TSW-103-07-T-S
14	1	J5	SMA	Johnson Components	142-0701-801
15	1	J11	HEADER 2x2	Samtec	TSW-102-07-T-D
16	1	J17	CONN TRBLK 2	Phoenix Contact	1729018
17	1	J18	USB Type B	Tyco	292304-1
18	1	J19	5X2 Shrouded Header	Tyco	5103309-1
19	5	J20,J21,J22, J23,J24	JUMPER	Samtec	TSW-102-07-T-S

Si535x-20QFN-EVB

Table 1. Si535x Bill of Materials (Continued)

Item	Qty	Reference	Value	Manufacturer	Part Number
20	11	R3,R4,R5,R8,R9, R23,R24,R52,R53, R56,R59	0	Venkel	CR0603-16W-000
21	4	R12,R13,R39,R40	2 k Ω	Venkel	CR0603-10W-2001F
22	2	R64,R66	2 k Ω	Venkel	CR0603-10W-2001F
23	5	R25,R26,R29,R30, R31	100 k Ω	Venkel	CR0603-10W-104J
24	8	R36,R37,R38,R42, R44,R49,R50,R55	1 k Ω	Venkel	CR0402-16W-102J
25	1	R41	0 Ω	Venkel	CR0402-16W-000
26	3	R43,R46,R47	220 Ω	Venkel	CR0402-16W-221J
27	4	R45,R48,R60,R61	1.02 k Ω	Venkel	TFCR0402-16W-E-1021B
28	8	R51,R54,R57,R58, R62,R63,R65,R68	0 Ω	Venkel	CR0603-16W-000
29	1	R67	412 Ω	Venkel	TFCR0402-16W-E-4120B
30	3	R69,R70,R71	4.99 k Ω	Venkel	CR0603-16W-4991F
31	5	R72,R73,R74,R90, R91	20 Ω	Venkel	CR2512-1W-20R0D
32	7	R75,R76,R78,R92, R95,R97,R106	10 k Ω	Venkel	CR0603-16W-1002F
33	6	R77,R79,R80,R93, R94,R96	100 k Ω	Venkel	CR0603-10W-1003F
34	5	R81,R84,R87, R99,R102	5.90 k Ω	Venkel	CR0603-16W-5901F
35	5	R82,R85,R88, R100,R103	9.53 k Ω	Venkel	CR0603-16W-9531F
36	5	R83,R86,R89, R101,R104	4.42 k Ω	Venkel	CR0603-16W-4421F
37	1	R98	6.98 k Ω	Venkel	CR0603-16W-6981F
38	2	R105,R107	2.55 k Ω	Venkel	CR0603-16W-2551F
39	1	R109	49.9 Ω	Venkel	CR0603-16W-49R9F
40	1	S1	SW PUSHBUTTON	Mountain Switch	101-0161-EV
41	6	TP2,TP3,TP6, TP10,TP20,TP29	BLACK	Kobiconn	151-203-RC

Table 1. Si535x Bill of Materials (Continued)

Item	Qty	Reference	Value	Manufacturer	Part Number
42	3	TP4,TP5,TP11	RED	Kobiconn	151-207-RC
43	14	TP7,TP8,TP9, TP30,TP31,TP32, TP33,TP34,TP35, TP36,TP37,TP38, TP39,TP52	WHITE	Kobiconn	151-201-RC
44	18	TP12,TP13,TP14, TP15,TP16,TP17, TP18,TP19,TP21, TP22,TP23,TP24, TP25,TP26,TP27, TP28,TP50,TP51	RED	Kobiconn	151-207-RC
45	10	TP40,TP41,TP42, TP43,TP44,TP45, TP46,TP47,TP48, TP49		1-pin header	
46	1	U2	PCA9517D	NXP	PCA9517D
47	1	U3	ADG736BRMZ	ADI	ADG736BRMZ
48	1	U4	C8051F340	SiLabs	C8051F340-GQ
49	1	U5	2.5V	Analog Devices	AD1582BRT
50	2	U6,U7	ADG728	Analog Devices	ADG728BRUZ
52	7	U9,U10,U11,U12, U13,U14,U15	TPS76201	TI	TPS76201DBV
53	1	Y1	27 MHz	TXC	7M-27.000MEEQ-T

Si535x-20QFN-EVB

9. Approved Crystals

The crystals listed in Table 2 have been approved for use with the Si5350/51 family of devices. Note that this device has on-chip load capacitors that can be configured for 0, 6, 8, and 10 pF. For crystals with any other rated load capacitance, external capacitors may be required to achieve the best absolute accuracy.

Table 2. Approved Crystals

Mfr	Part Number	Freq	Load Capacitance	Initial Accuracy	Stability over Temp	Web Site
Kyocera	CX3225SB25000D0FLJZ1	25 MHz	8 pF	±10 ppm	±15 ppm	http://global.kyocera.com/index.html
	CX3225SB27000D0FLJZ1	27 MHz				
Sunny	SP10115J6-25.000MHz	25 MHz	10 pF	±15 ppm	±30 ppm	http://www.sunny-usa.com/
	SP10115J6-27.000MHz	27 MHz				
NDK	NX3225GA-25.000M-STD-CRG-2	25 MHz	8 pF	±20 ppm	±30 ppm	http://www.ndk.com/en/
	NX3225GA-27.000M-STD-CRG-2	27 MHz				
Epson	FA-238 25.0000MB-K	25 MHz	10 pF	±50 ppm	±30 ppm	http://www.eea.epson.com/
TXC	7M-27.000MEEQ	27 MHz	10 pF	±10 ppm	±10 ppm	http://www.txc.com.tw

NOTES:

Si535x-20QFN-EVB

CONTACT INFORMATION

Silicon Laboratories Inc.
400 West Cesar Chavez
Austin, TX 78701
Tel: 1+(512) 416-8500
Fax: 1+(512) 416-9669
Toll Free: 1+(877) 444-3032

Please visit the Silicon Labs Technical Support web page:
<https://www.silabs.com/support/pages/contacttechnicalsupport.aspx>
and register to submit a technical support request.

The information in this document is believed to be accurate in all respects at the time of publication but is subject to change without notice. Silicon Laboratories assumes no responsibility for errors and omissions, and disclaims responsibility for any consequences resulting from the use of information included herein. Additionally, Silicon Laboratories assumes no responsibility for the functioning of undescribed features or parameters. Silicon Laboratories reserves the right to make changes without further notice. Silicon Laboratories makes no warranty, representation or guarantee regarding the suitability of its products for any particular purpose, nor does Silicon Laboratories assume any liability arising out of the application or use of any product or circuit, and specifically disclaims any and all liability, including without limitation consequential or incidental damages. Silicon Laboratories products are not designed, intended, or authorized for use in applications intended to support or sustain life, or for any other application in which the failure of the Silicon Laboratories product could create a situation where personal injury or death may occur. Should Buyer purchase or use Silicon Laboratories products for any such unintended or unauthorized application, Buyer shall indemnify and hold Silicon Laboratories harmless against all claims and damages.

Silicon Laboratories and Silicon Labs are trademarks of Silicon Laboratories Inc.

Other products or brandnames mentioned herein are trademarks or registered trademarks of their respective holders.