



Chipsmall Limited consists of a professional team with an average of over 10 year of expertise in the distribution of electronic components. Based in Hongkong, we have already established firm and mutual-benefit business relationships with customers from,Europe,America and south Asia,supplying obsolete and hard-to-find components to meet their specific needs.

With the principle of "Quality Parts,Customers Priority,Honest Operation,and Considerate Service",our business mainly focus on the distribution of electronic components. Line cards we deal with include Microchip,ALPS,ROHM,Xilinx,Pulse,ON,Everlight and Freescale. Main products comprise IC,Modules,Potentiometer,IC Socket,Relay,Connector.Our parts cover such applications as commercial,industrial, and automotives areas.

We are looking forward to setting up business relationship with you and hope to provide you with the best service and solution. Let us make a better world for our industry!



## Contact us

Tel: +86-755-8981 8866 Fax: +86-755-8427 6832

Email & Skype: info@chipsmall.com Web: www.chipsmall.com

Address: A1208, Overseas Decoration Building, #122 Zhenhua RD., Futian, Shenzhen, China



## Si537x-EVB EVALUATION BOARD USER'S GUIDE

### Description

The Si5374/75/76 Any Frequency Precision Clocks are based on Silicon Labs 3rd-generation DSPLL technology, which provides any-frequency synthesis in a highly integrated PLL solution that eliminates the need for external VCXO and loop filter components. The devices have excellent phase noise and jitter performance. All of the devices support 350 fs RMS jitter generation across the 12 kHz to 20 MHz jitter filter bandwidth. For all devices, the DSPLL loop bandwidth is digitally programmable, providing jitter performance optimization at the application level. These devices are ideal for providing clock multiplication/clock division and jitter attenuation in mid-range and high-performance timing applications where printed circuit board real estate is at a premium.

### Features

The Si537x-EVB includes the following:

- CD with documentation and EVB software including the Si537x\_DSPLLsim configuration software utility.
- EVB circuit board
- Si537x-EVB User's Guide (this document)

### Functional Block Diagram

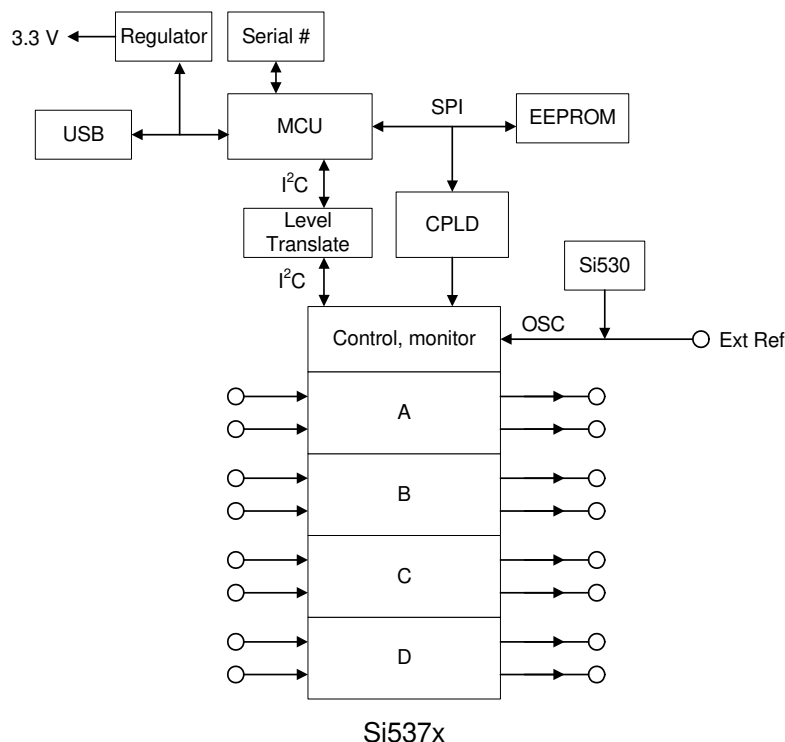



# Si537x-EVB

## 1. Introduction

The Si537x-EVB provides a platform for evaluating Silicon Labs' Si5374, Si5375, and Si5376 Any Frequency Precision Clocks. These devices are jitter attenuating quad DSPLLs that are microprocessor controlled using an I<sup>2</sup>C interface. The Si5374 and the Si5376 have eight clock inputs and 8 clock outputs, whereas the Si5375 has 4 clock inputs and 4 clock outputs. The Si5374 has the added feature of lower loop BW than the Si5375 and Si5376.

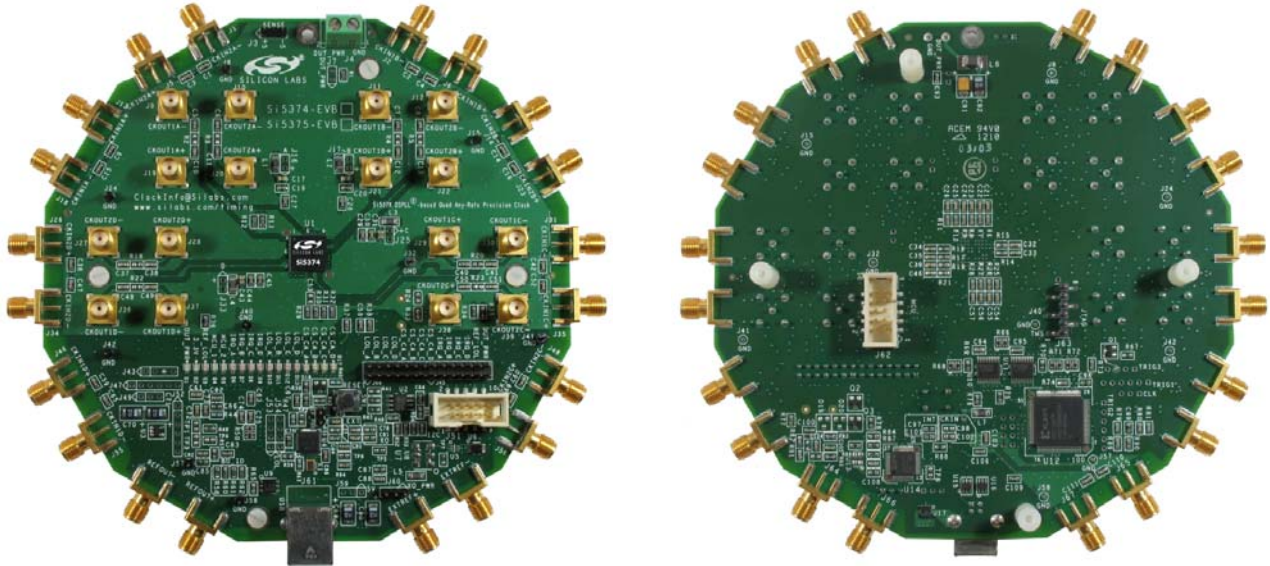

Figure 1. Si537x-EVB

Table 1. Si537x Selection Summary

Device	# Input/ Output Clocks	Frequency Range		DSPLL Loop Bandwidth Range	Hitless Switching	VCO Freeze	Free Run	Digital Hold	Package
		Input	Output						
Si5374	8/8	2 kHz–710 MHz	2 kHz–808 MHz	4–525 Hz	✓		✓	✓	10x10 mm 80-PBGA
Si5375	4/4	2 kHz–710 MHz	2 kHz–808 MHz	60 Hz–8.4 kHz		✓	✓		10x10 mm 80-PBGA
Si5376	8/8	2 kHz–710 MHz	2 kHz–808 MHz	60 Hz–8.4 kHz	✓		✓	✓	10x10 mm 80-PBGA

## 2. Applications

The Si5374/75/76 Any Frequency Precision Clocks offer a comprehensive feature set, including any frequency synthesis, jitter attenuation, fully integrated loop filter, multiple clock inputs, multiple clock outputs, alarm and status outputs, hitless switching between multiple input clocks, programmable output clock format (LVPECL, LVDS, CML, CMOS), and output phase adjustment between all output clocks. For more details, consult the Silicon Labs timing products website at [www.silabs.com/timing](http://www.silabs.com/timing).

The Si537x-EVB has a Silicon Labs MCU (C8051F430) that supports USB communications with a PC host. The Si5374/75/76 devices are controlled and monitored through the I<sup>2</sup>C serial port. A CPLD is connected to the MCU and stores pin configuration data and reads the device status pins. The MCU communicates to the Si537x device using I<sup>2</sup>C through a voltage level translator. However, the user has the option of bypassing the MCU and controlling the devices from an external serial device. On-board termination is included so that the user can evaluate either single-ended or differential as well as ac or dc coupled clock inputs and outputs. A separate DUT (device under test) power supply connector is included. LEDs are provided for convenient monitor of key status signals. The user can select between a number of reference oscillator options, including external sources and various on-board options.

For more detailed information about the applications of these devices, please see their respective data sheets.

## 3. Si5374/75/76-EVB Quick Start

For more detailed information about these devices, see their respective data sheets.

## 4. Functional Description

The Si537x-EVB and software allows for a complete and simple evaluation of the functions, features, and performance of the Si5374/75/76 Any Frequency Precision Clocks. For the following material, refer to the schematics in section “7. Schematics.”

### 4.1. Block Diagram

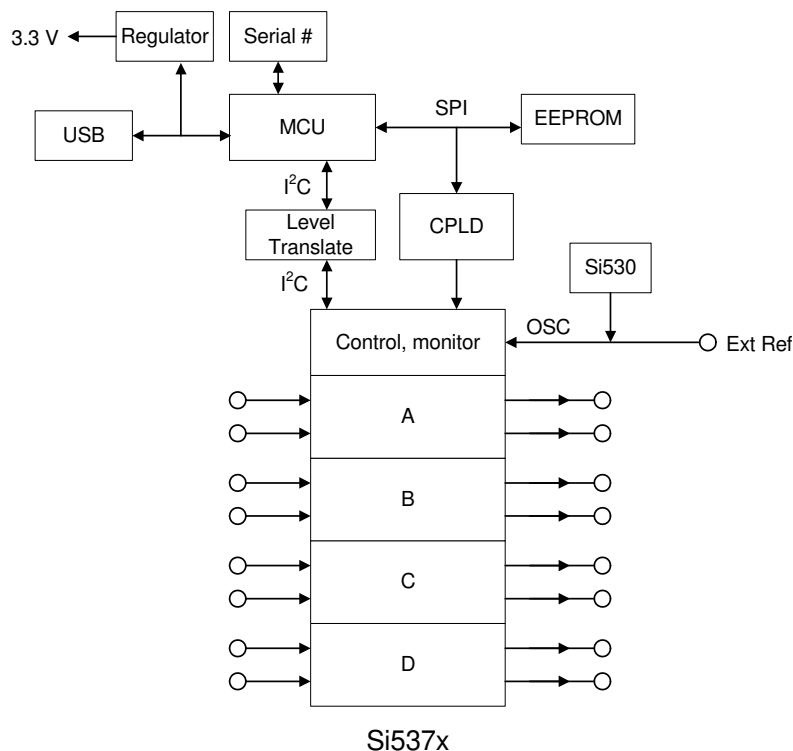

**Figure 2. Si537x-EVB Block Diagram**

Figure 2 is a block diagram of the evaluation board and it is helpful to refer to this diagram. The MCU communicates to the host PC over a USB connection. The MCU controls and monitors the Si537x pins through the CPLD, which provides level translation between the MCU and the Si537x. I<sup>2</sup>C level translation is provided separately. A number of different options are provided for the required Si537x external reference oscillator.

### 4.2. Si537x Device

To minimize noise and crosstalk, the Si537x device has separate and filtered V<sub>DD</sub> supplies. Two-pin jumper plugs (J16, J17, J25, and J33) are provided so that the distinct power supplies can be monitored.

### 4.3. Input Clocks

The input clocks are all located at the edge of the board. For each clock input pair, each input is ac terminated with 50 Ω to ground. With this configuration, single ended inputs can be implemented by simply leaving the unused clock input disconnected. If low frequency clock inputs are in use, the reactance of the 100 nf capacitors (C12, C13, C14, etc.) can become significant and they should be replaced with 0 Ω resistors. In some circumstances, the ac termination should be removed and replaced. CMOS inputs are typically best terminated by using series source termination at the output of the CMOS driver and completely removing all of the on-board input termination.

Regardless of the termination scheme in use, a scope should be used to verify that none of the clock input specifications found in the data sheet are being violated.

## 4.4. Output clocks

The output clocks all use vertical mount SMA connectors and are ac coupled. There may be circumstances (e.g., CMOS outputs) for which the 100 nF capacitors should be replaced with 0  $\Omega$  resistors. Pads for resistors between the two halves of the outputs are provided for CMOS outputs so that the outputs can be put in parallel for greater drive strength.

## 4.5. OSC Reference Source

The Si537x requires a low-jitter reference on its OSC\_P and OSC\_N input pins. To provide a clock source, the user has a number of different options:

1. The factory default configuration is a 121.109 MHz Si530 crystal oscillator (XO). For this configuration install C78 and C81 (in the silkscreen XO box on the top of the board), remove C97 and C101 (in the INT silkscreen box on the bottom of the board), and remove C77 and C80 (in the silkscreen box EXT on the top of the board). J50 should be removed and J60 should select the desired XO supply voltage of 3.3 V by jumpering J60.2 to J60.3.
2. There are provisions for three different XO oscillator packages in industry standard pinouts: 5x7 mm, 3.2x5 mm, and 3.2x2.5 mm. If any of these are used, be sure to install C78 and C81 (in the silkscreen XO box on the top of the board), remove C97 and C101 (in the INT silkscreen box on the bottom of the board), and remove C77 and C80 (in the silkscreen box EXT on the top of the board). J50 should be removed and J60 should select the desired XO supply voltage of either the Si537x  $V_{DD}$  or 3.3 V.
3. An off-board, external reference oscillator may be used instead of the Si530 XO. If this is desired, C98 and C102 (in the CKIN silkscreen box on the bottom of the board), C101 and C97 (in the INT silkscreen box on the bottom of the board), and C78 and C81 (in the silkscreen XO box on the top of the board) should all be removed and C77 and C80 (in the EXT silkscreen box on the top of the board) should be installed. If this mode is selected, the clock input should be applied to J64 and J66. Both J50 and J60 should be removed so that the other references sources are not powered and do not add noise.
4. A PCB footprint for a reference Si5326 is included on the EVB. If it is installed, the Si5326 is initialized by the MCU and EEPROM so that it powers up with an output that is 114.285 MHz based on its crystal, X1. The output of the Si5326 can be monitored at J65 and J67 and can be changed to most any frequency using *DSPLLsim*. Free run at 114.285 MHz is the factory default Si5326 frequency plan. If a reference OSC frequency in the 37–41 MHz band is to be used, be sure to set the RATE register (reg 2) for all of the DSPLLs to 0101.

For options 2 and 4 above, an external OSC reference XO in the 37–41 MHz frequency band can also be used. With this approach, the output jitter will be higher by an amount that is illustrated in “AN591: Crystal Selection for the Si5315 and Si5317,” Figures 3 and 4. It will also be necessary to create an Si537xDSPLLsim frequency plan with the appropriate RATE\_REG (at addr 2) setting of 0001.

It is also possible to have the reference Si5326 lock onto an external clock source instead of locking to its 114.285 MHz crystal in free run mode. If this mode is desired, install C98 and C102 (in the CKIN silkscreen box on the bottom of the board) and then load the appropriate frequency plan into the reference Si5326 using *DSPLLsim*. The external clock source is connected to J64 and J66. If the Si5326 is being used, J50 should be installed and J60 should be removed.

Though they will result in slightly lower performance, single ended reference clock inputs can be connected to J66, with the unused J64 connected to ground. In all cases, when a single ended reference oscillator is in use, C53 (located close to the Si537x) should be installed.

# Si537x-EVB

---

## 4.6. CPLD

The CPLD provides various functions including level translation and the buffering of monitor/control of signals for the Si537x DUT and the Si5326 reference source. Examples are the LOL, IRQ, and CS\_CA signals from the Si537x as well as the SPI port connection to the reference Si5326.

## 4.7. MCU

The MCU is the intermediary between the PC host and the Si537x DUT. The host's USB port provides power for the MCU and the LEDs through a 3.3 V regulator (U17). U6 provides I<sup>2</sup>C level translation to the DUT V<sub>DD</sub> voltage level. U2 is an EEPROM that is used to initialize the reference Si5326. J51 is an I<sup>2</sup>C serial port connector by which an external I<sup>2</sup>C master can control the on-board Si537x or by which the on-board MCU can control an Si537x that resides on a external target board.

## 4.8. Power and LEDs

J4 is the main Si537x power connector. Remote sensing for the power supply is provided by J3. DUT current can be monitored by removing R1 and connecting to J7. U10 and U11 are buffers that are used to drive the LEDs. The status outputs are available at J44/45.

## 5. Connectors and LEDs

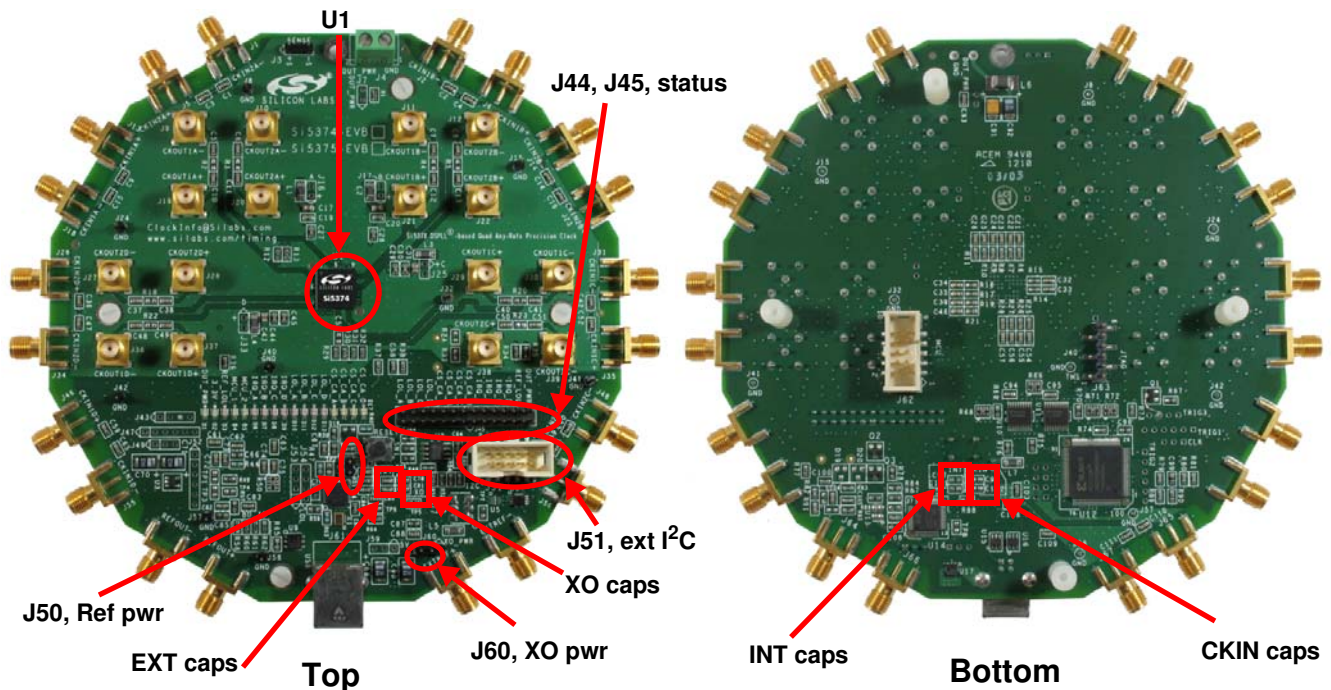

**Figure 3. Connectors, Top, and Bottom Views**

J51 can be used as an attachment point for controlling the Si537x DUT from an external I<sup>2</sup>C master or to use the MCU to control an Si537x DUT that resides on an external target board.

To control the on-board Si537x from an external I<sup>2</sup>C master, disconnect the cable from the USB connector (J61), thereby depriving the EVB of its 5 V power source. A lack of 3.3 V power will disable the U6 level translator (by virtue of U6.8) so that the MCU will be isolated from the external I<sup>2</sup>C bus that should be applied to J51.

To control an external Si537x from the on-board MCU, the on-board Si537x must be held in reset so that it does not assert either of the two I<sup>2</sup>C bus signals. This can be done by opening the Si537x Register Programmer and going to the Options pull down menu on the top toolbar and selecting "Switch to External Control Mode."



**Table 2. External I<sup>2</sup>C**

<b>J51</b>	<b>Name</b>	<b>Comment</b>
J51.1	SDA	serial data
J51.3	SCL	serial clock
J51.9	DUT_RST_L	DUT reset

J45 is used to make external connections to status signals:

**Table 3. Status**

<b>J45</b>	<b>Name</b>	<b>Comment</b>
J45.27	DUT_PWR	+2.5 or 1.8 V
J45.25	REF_LOL	
J45.23	IRQ_D	
J45.21	IRQ_C	
J45.19	IRQ_B	
J45.17	IRQ_A	
J45.15	CS_CA_D	
J45.13	CS_CA_C	
J45.11	CS_CA_B	
J45.9	CS_CA_A	
J45.7	LOL_D	
J45.5	LOL_C	
J45.3	LOL_B	
J45.1	LOL_A	

The LEDs are used to quickly determine the board status:

**Table 4. LED Descriptions**

<b>LED</b>	<b>Color</b>	<b>Label</b>
D17	yellow	CS_CA_D
D16	yellow	CS_CA_C
D15	yellow	CS_CA_B
D14	yellow	CS_CA_A
D13	red	LOL_D
D12	red	LOL_C
D11	red	LOL_B
D10	red	LOL_A
D9	red	IRQ_D
D8	red	IRQ_C
D7	red	IRQ_B
D6	red	IRQ_A
D5	green	MCU_2
D4	green	MCU_1
D3	red	REF_LOL
D2	green	3.3 V
D1	green	DUT_PWR

# Si537x-EVB

---

## 6. EVB Software Installation

The release notes and the procedure for installing the EVB software can be found on the release CD included with the EVB. These items can also be downloaded from the Silabs web site: [www.silabs.com/timing](http://www.silabs.com/timing). Follow the links for 4-PLL Jitter attenuators, and look under the Tools tab.

<b>Program</b>	<b>Description</b>
Si537x_DSPLLsim	Provides the high level control of the Si537x device. It has the frequency planning wizard as well as control of the pins in an organized, intuitive manner. Register maps and other configuration files can be saved and opened.
Setting Utility	This application allows for quick read/write access to each control word of the Si537x device. It can save and open text files.
Register Prgmr	Provides a low-level, hex register read/write capability on a byte basis (as opposed to control word). Register map files can be opened and saved in its batch mode.
Register Viewer	Displays the current register map data in a table format sorted by register address. Can save and print the register map.

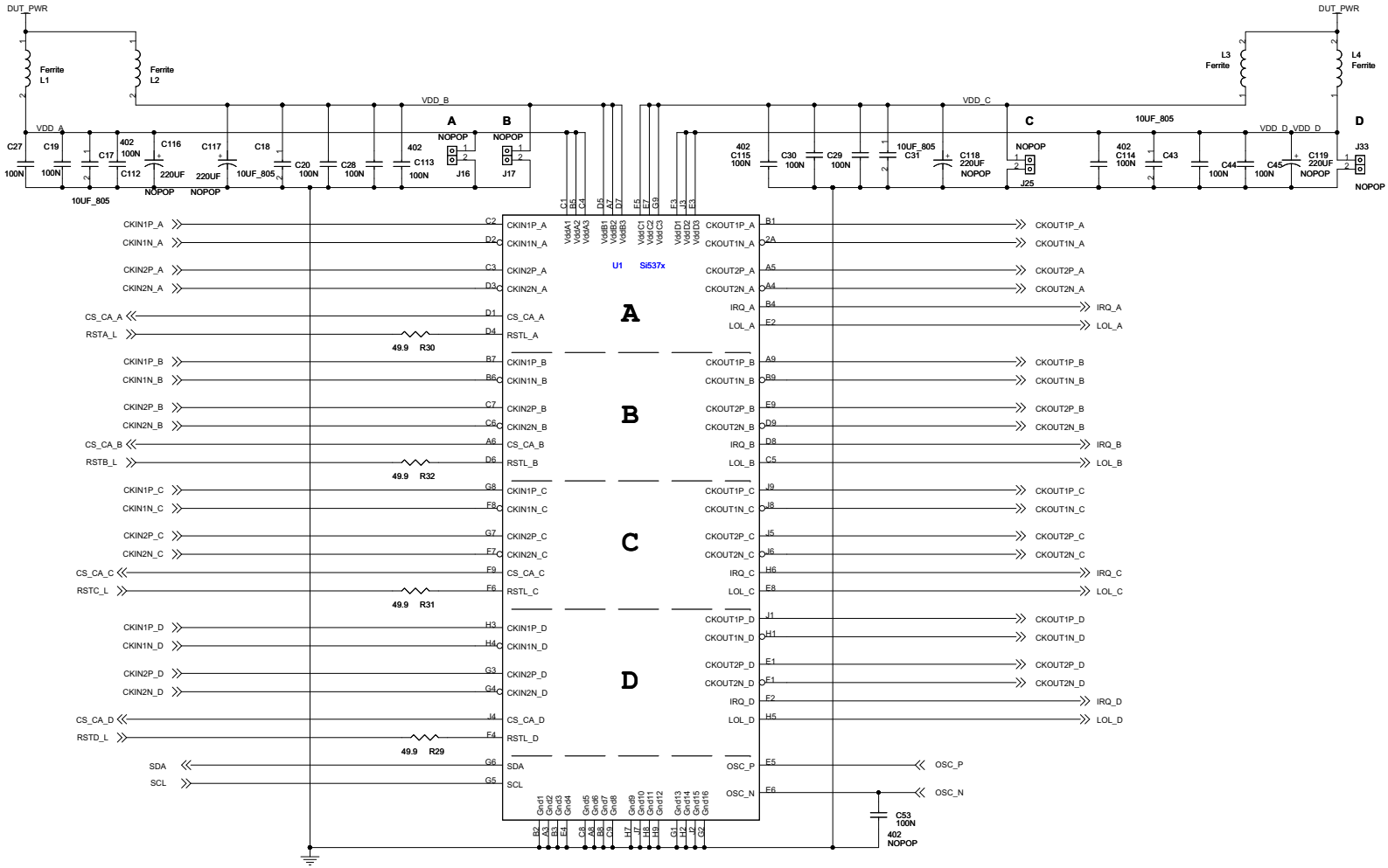

Figure 4. Si537x



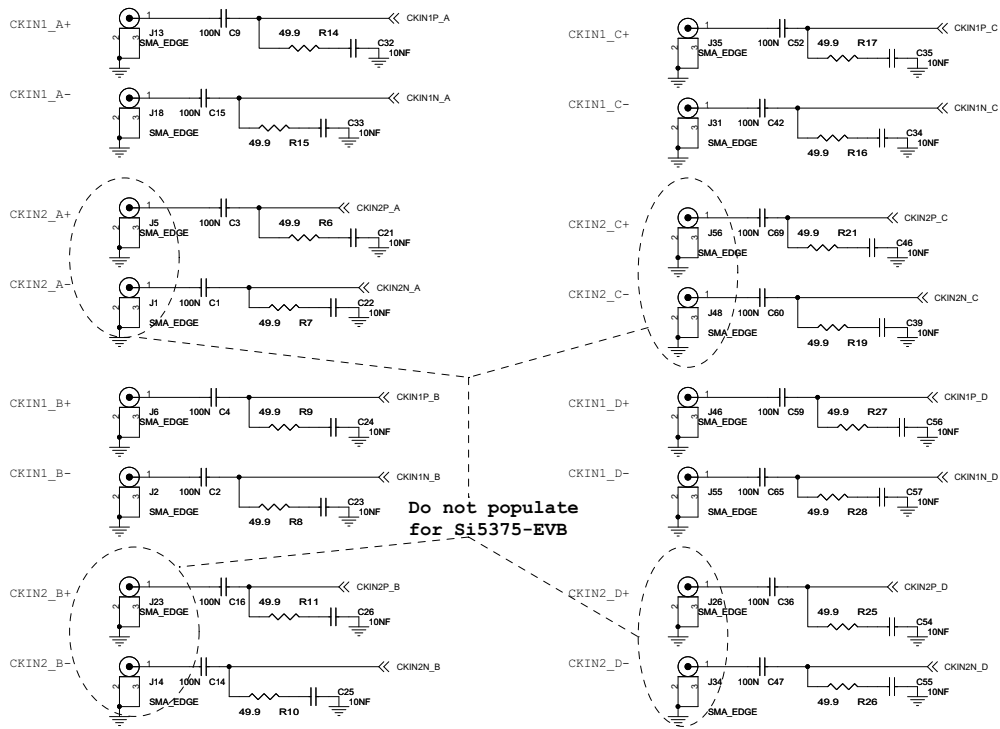

Figure 5. Clock Inputs

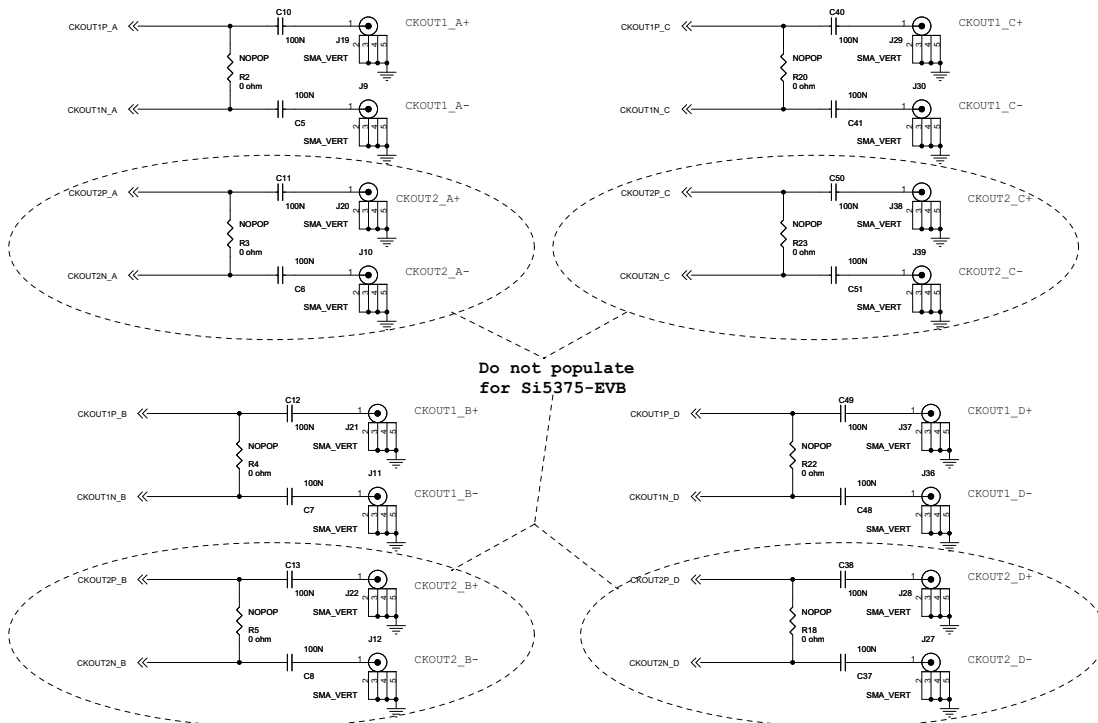

Figure 6. Clock Outputs

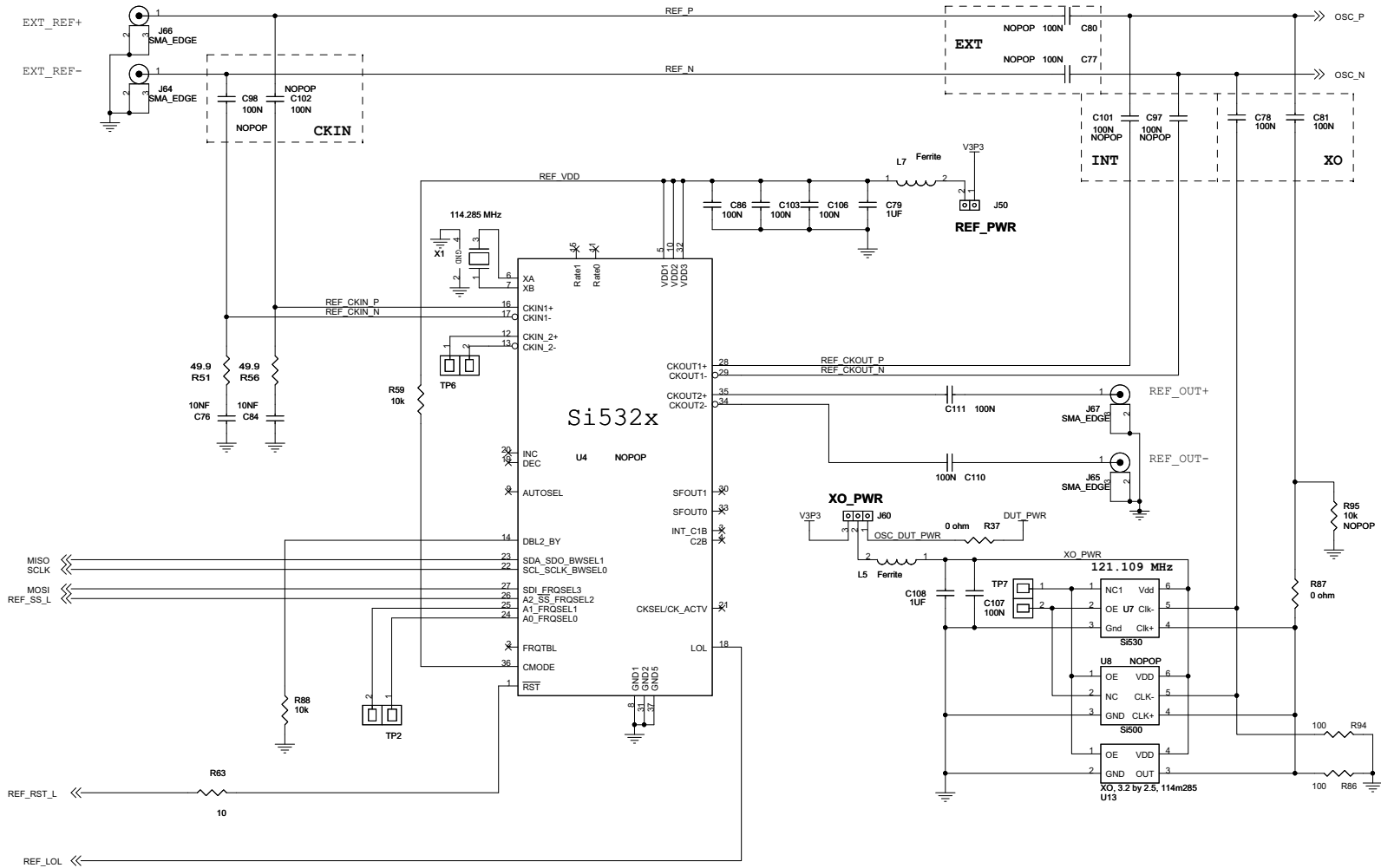

Figure 7. Reference Oscillators

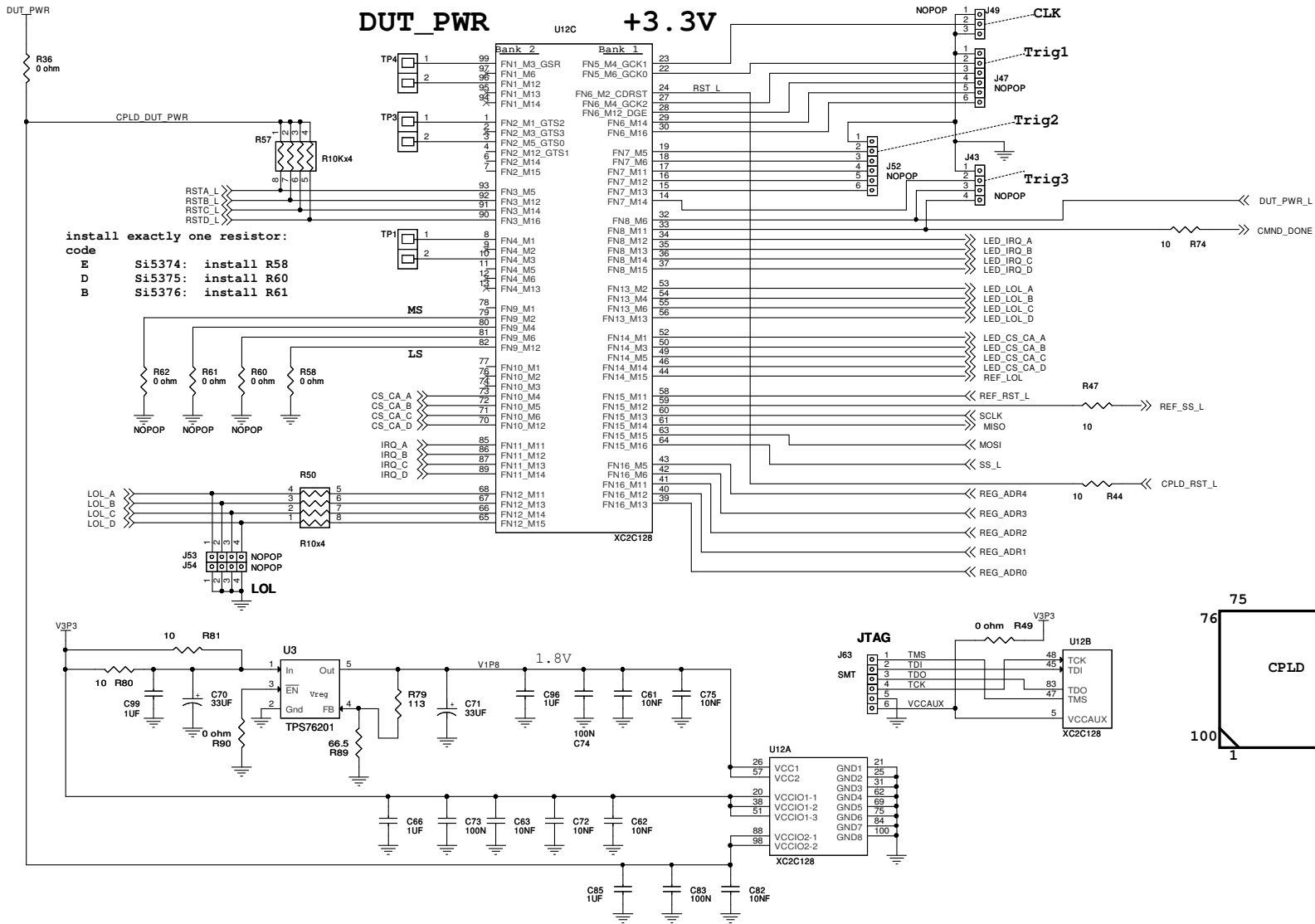

Figure 8. CPLD

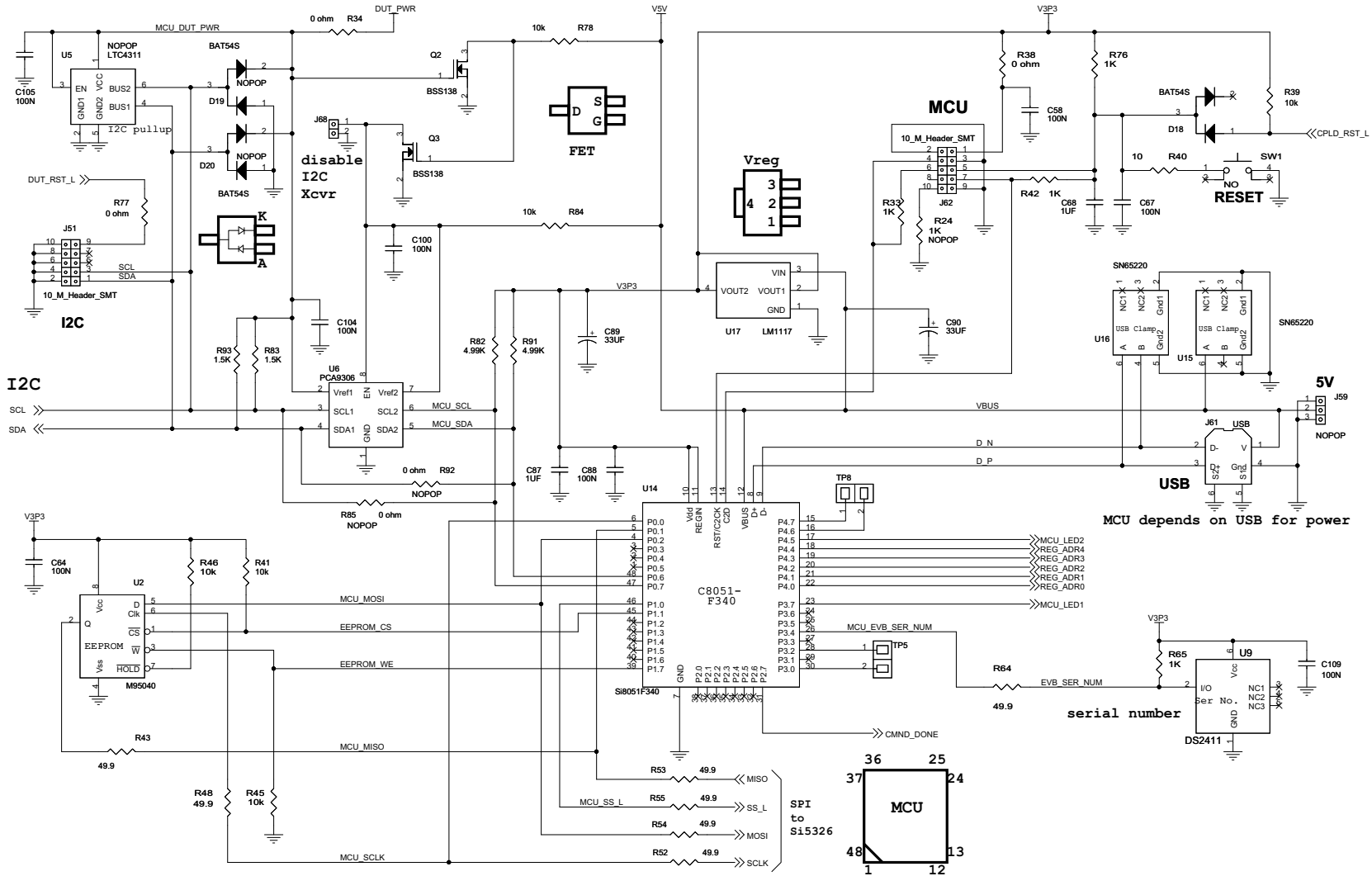

Figure 9. MCU



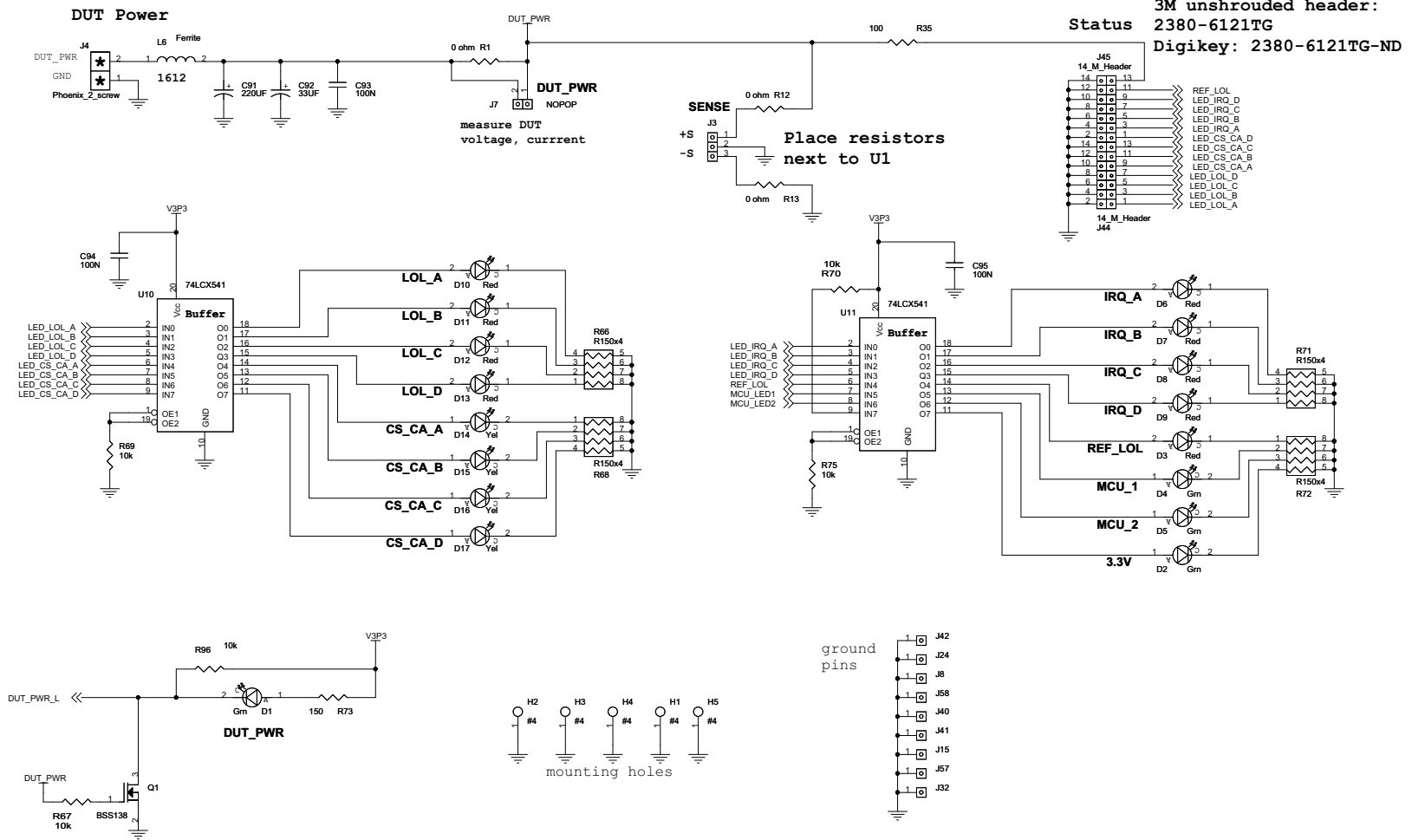

Figure 10. Power and LEDs

## 8. Bill of Materials

Table 5. Si537x-EVB Bill of Materials

Item	Qty	Reference	Part	Mfgr	Mfr Part Num	BOM	Digikey	Footprint
1	62	C1,C2,C3,C4, C5,C6,C7,C8, C9,C10,C11, C12,C13,C14, C15,C16,C19, C20,C27,C28, C29,C30,C36, C37,C38,C40, C41,C42,C44, C45,C47,C48, C49,C50,C51, C52,C58,C59, C60,C64,C65, C67,C69,C73, C74,C83,C86, C88,C93,C94, C95,C97,C100, C101,C103, C104,C105, C106,C107, C109,C110,C111	100N	Venkel	C0603X7R160-104KNE			603
2	4	C17,C18,C31,C43	10UF_805	Venkel	C0805Y5V6R3106ZN			805
3	24	C21,C22,C23,C24, C25,C26,C32,C33, C34,C35,C39,C46, C54,C55,C56,C57, C61,C62,C63,C72, C75,C76,C82,C84	10NF	Venkel	C0603X7R160-103KNE			603
5	8	C66,C68,C79,C85, C87,C96,C99,C108	1UF	Venkel	C0603X7R6R3-105KNE			603
6	3	C70,C89,C90	33UF	Venkel	TA006TCM336MBR			3528
7	2	C71,C92	33UF	Venkel	TA0006TCM336MBR			3528
9	1	C91	220UF	Kemet	T494B227M004AT		399-4631-1-ND	SM_C_3528_21
10	4	D1,D2,D4,D5	Grn	Panasonic	LN1371G		P491CT-ND	LED_gull
11	9	D3,D6,D7,D8,D9, D10,D11, D12,D13	Red	Lumex	LN1271RAL		P493CT-ND	LED_gull
12	4	D14,D15,D16,D17	Yel	Panasonic	LN1471YTR		P11125CT-ND	LED_gull
13	1	D18	BAT54S	Fairchild	BAT54S		BAT54SFSCCT-ND	SOT23

# Si537x-EVB

**Table 5. Si537x-EVB Bill of Materials (Continued)**

Item	Qty	Reference	Part	Mfgr	Mfr Part Num	BOM	Digikey	Footprint
16	20	J1,J2,J5,J6,J13,J14,J18,J23,J26,J31,J34,J35,J46,J48,J55,J56,J64,J65,J66,J67	SMA_EDGE	Johnson	142-0701-801		J502-ND	SMA_EDGE_p062
17	2	J3,J60	Jmpr_3pin					3pin_p1pitch
18	1	J4	Phoenix_2_screw	Phoenix	MKDSN 1.5/2-5.08		277-1247-ND	Phoenix2pinM_p2pitch
20	9	J8,J15,J24,J32,J40,J41,J42,J57,J58	Jmpr_1pin					1pin_p1pitch
21	16	J9,J10,J11,J12,J19,J20,J21,J22,J27,J28,J29,J30,J36,J37,J38,J39	SMA_VERT	Johnson	142-0701-211		J494-ND	SMA_VERT
23	2	J44,J45	unshrouded_Header	3M	2380-6121TG		2380-6121TG-ND	28pin thru hole header
26	1	J50	Jmpr_2pin					
27	2	J51,J62	10_M_Head er_SMT	Samtec	HTST-105-01-lm-dv-a			10pinMdualHeader_p1pitch_smt
28	1	J61	USB	FCI	61729-0010BLF		609-1039-ND	USB_typeB
29	1	J63	SMT	Sullins	GZC36SABN-M30		S1033-36-ND	6pin_m_smt
30	6	L1,L2,L3,L4,L5,L7	Ferrite	Venkel	FBC1206-471H			1206
31	1	L6	Ferrite	Steward	HI1612X560R-10			1612
32	3	Q1,Q2,Q3	BSS138	On Semi	BSS138LT1G		BSS138LT10SCT-ND	SOT23
33	14	R1,R12,R13,R29,R30,R31,R32,R34,R36,R37,R38,R49,R61,R77,R87,R90,R23,R62,R85,R92	0 Ω	Venkel	CR0603-16W-000T			603
35	25	R6,R7,R8,R9,R10,R11,R14,R15,R16,R17,R19,R21,R25,R26,R27,R28,R43,R48,R51,R52,R53,R54,R55,R56,R64	49.9	Venkel	CR0603-16W-49R9FT			603
37	4	R33,R42,R65,R76	1K	Venkel	CR0603-16W-1001FT			603
38	1	R35, R86, R94	100	Venkel	CR0603-16W-1000FT			603

**Table 5. Si537x-EVB Bill of Materials (Continued)**

Item	Qty	Reference	Part	Mfgr	Mfr Part Num	BOM	Digikey	Footprint
39	13	R39,R41,R45,R46, R57,R59,R67,R69, R70,R75,R78,R84, R88	10k	Venkel	CR603-16W-1002FT			603
40	7	R40,R44,R47,R63, R74,R80,R81	10	Venkel	CR0603-16W-10R0FT			603
41	1	R50	R10x4	Panasonic	EXB-38V100JV		Y9100CT-ND	1206x4
42	4	R66,R68,R71,R72	R150x4	Panasonic	EXB-38V151JV		Y9151CT-ND	1206x4
43	1	R73	150	Venkel	CR0603-16W-1500FT			603
44	1	R79	113	Venkel	CR0603-16W-1130FT			603
45	2	R82,R91	4.99K	Venkel	CR0603-16W-4991FT			603
46	2	R83,R93	1.5K	Venkel	CR0603-16W-1501FT			603
48	1	R89	66.5	Venkel	CR0603-16W-66R5FT			603
49	1	SW1	NO	Mountain Switch	101-0161-EV		101- 0161(mouser)	4pin Switch
51	1	U1	Si537x	Silicon Labs	Si537x			10x10 mm BGA
52	1	U2	M95040	ST Micro	M95040-WMN6P			SOIC-8
53	1	U3	TPS76201	TI	TPS76201DBVT		296-11013-1-ND	SOT23-5
56	1	U6	PCA9306	TI	PCA9306DCTR-ND		296-18509-1-ND	SM8
57	1	U7	Si530_2.5V PECL	Silicon Labs	530EB121M109DG			5x7 mm
59	1	U9	DS2411	Maxim/ Dallas	DS2411P			TSOC-6
60	2	U10,U11	74LCX541	Fairchild	74LCX541MTC_NL		TC74LCX541FTF CT-ND	TSSOP-20
61	1	U12	XC2C128	Xilinx	XC2C128-7VQG100I			VQG100
63	1	U14	Si8051F340	Silicon Labs	C8051F340-GQ			TQFP-48
64	2	U15,U16	SN65220	TI	SN65220DBVT		296-9694-1-ND	SOT23-6
65	1	U17	FAN1540B	Fairchild	FAN1540BPMX		FAN1540BMPXC T-ND	MLP6
66	1	X1	114.285 MH z	TXC	7MA1400014			xtal_3p2by2p5
	4		spacer	SPC Tech- nology	2397			
	4		screw	Richco	NSS-4-4-01			
4	1	C53	10NF	Venkel	C0603X7R160-103KNE	NOPOP		603
8	6	C77,C78,C80,C81, C98,C102	100N	Venkel	C0603X7R160-104KNE	NOPOP		603



# Si537x-EVB

**Table 5. Si537x-EVB Bill of Materials (Continued)**

Item	Qty	Reference	Part	Mfgr	Mfr Part Num	BOM	Digikey	Footprint
14	2	D19,D20	BAT54S	Fairchild	BAT54S	NOPOP	BAT54SFSC-ND	SOT23
19	5	J7,J16,J17,J25,J33	Jmpr_2pin			NOPOP		
22	3	J43,J53,J54	Jmpr_4pin			NOPOP		4pin_p1pitch
24	2	J47,J52	Jmpr_6pin			NOPOP		6pin_p1pitch
25	2	J49,J59	Jmpr_3pin			NOPOP		3pin_p1pitch
34	14	R2,R3,R4,R5,R18, R20,R22,	0 ohm	Venkel	CR0603-16W-000T Note: install R58 for Si5374-EVB, install R60 for Si5375-EVB	NOPOP		603
36	1	R24	1K	Venkel	CR0603-16W-1001FT	NOPOP		603
50	8	TP1,TP2,TP3,TP4, TP5,TP6, TP7,TP8	test_points	none	none	NOPOP		
54	1	U4	Si5326	Silicon Labs	Si5326C-C-GM	NOPOP		QFN-36
55	1	U5	LTC4311	LinearTech	LTC4311ISC6#TRMPBF	NOPOP	LTC4311CSC6#T RMPBFCT-ND	SC70
58	1	U8	Si500	Silicon Labs		NOPOP		3x5 mm_6pin
62	1	U13	XO, 3.2 by 2.5	Pericom	FKB420001	NOPOP		3x2 mm
67	1	—	heatsink	Aavid Thermalloy	375324B00035G	NOPOP		10x10 mm

## 9. Layout

Contact Silicon Labs to obtain the Allegro Board file.

## DOCUMENT CHANGE LIST

### Revision 0.2 to Revision 0.3

- Various changes to accommodate 1.8 V operation.

### Revision 0.3 to Revision 0.4

- Removed software installation instructions and directed reader to refer to release CD or download from Silicon Labs web site.

### Revision 0.4 to Revision 0.5

- Changed U7 to LVPECL, part number Si530EB121M109G.
- Installed 100  $\Omega$  resistors at R94 and R86.

### Revision 0.5 to Revision 0.6

- Added Si5376.
- Updated "Description" on page 1.

**NOTES:**



## ClockBuilder Pro

One-click access to Timing tools, documentation, software, source code libraries & more. Available for Windows and iOS (CBGo only).

[www.silabs.com/CBPro](http://www.silabs.com/CBPro)



**Timing Portfolio**  
[www.silabs.com/timing](http://www.silabs.com/timing)



**SW/HW**  
[www.silabs.com/CBPro](http://www.silabs.com/CBPro)



**Quality**  
[www.silabs.com/quality](http://www.silabs.com/quality)



**Support and Community**  
[community.silabs.com](http://community.silabs.com)

### Disclaimer

Silicon Laboratories intends to provide customers with the latest, accurate, and in-depth documentation of all peripherals and modules available for system and software implementers using or intending to use the Silicon Laboratories products. Characterization data, available modules and peripherals, memory sizes and memory addresses refer to each specific device, and "Typical" parameters provided can and do vary in different applications. Application examples described herein are for illustrative purposes only. Silicon Laboratories reserves the right to make changes without further notice and limitation to product information, specifications, and descriptions herein, and does not give warranties as to the accuracy or completeness of the included information. Silicon Laboratories shall have no liability for the consequences of use of the information supplied herein. This document does not imply or express copyright licenses granted hereunder to design or fabricate any integrated circuits. The products must not be used within any Life Support System without the specific written consent of Silicon Laboratories. A "Life Support System" is any product or system intended to support or sustain life and/or health, which, if it fails, can be reasonably expected to result in significant personal injury or death. Silicon Laboratories products are generally not intended for military applications. Silicon Laboratories products shall under no circumstances be used in weapons of mass destruction including (but not limited to) nuclear, biological or chemical weapons, or missiles capable of delivering such weapons.

### Trademark Information

Silicon Laboratories Inc., Silicon Laboratories, Silicon Labs, SiLabs and the Silicon Labs logo, CMEMS®, EFM, EFM32, EFR, Energy Micro, Energy Micro logo and combinations thereof, "the world's most energy friendly microcontrollers", Ember®, EZLink®, EZMac®, EZRadio®, EZRadioPRO®, DSPLL®, ISOModem®, Precision32®, ProSLIC®, SiPHY®, USBXpress® and others are trademarks or registered trademarks of Silicon Laboratories Inc. ARM, CORTEX, Cortex-M3 and THUMB are trademarks or registered trademarks of ARM Holdings. Keil is a registered trademark of ARM Limited. All other products or brand names mentioned herein are trademarks of their respective holders.



**SILICON LABS**

Silicon Laboratories Inc.  
400 West Cesar Chavez  
Austin, TX 78701  
USA

<http://www.silabs.com>