



Chipsmall Limited consists of a professional team with an average of over 10 year of expertise in the distribution of electronic components. Based in Hongkong, we have already established firm and mutual-benefit business relationships with customers from,Europe,America and south Asia,supplying obsolete and hard-to-find components to meet their specific needs.

With the principle of “Quality Parts,Customers Priority,Honest Operation,and Considerate Service”,our business mainly focus on the distribution of electronic components. Line cards we deal with include Microchip,ALPS,ROHM,Xilinx,Pulse,ON,Everlight and Freescale. Main products comprise IC,Modules,Potentiometer,IC Socket,Relay,Connector.Our parts cover such applications as commercial,industrial, and automotives areas.

We are looking forward to setting up business relationship with you and hope to provide you with the best service and solution. Let us make a better world for our industry!



## Contact us

Tel: +86-755-8981 8866 Fax: +86-755-8427 6832

Email & Skype: info@chipsmall.com Web: www.chipsmall.com

Address: A1208, Overseas Decoration Building, #122 Zhenhua RD., Futian, Shenzhen, China



## CLASS D AUDIO AMPLIFIER REFERENCE DESIGN USER'S GUIDE

### 1. Kit Contents

The Si824x Class D Audio Amplifier Reference Design Kit contains the following items:

- Audio Class D Amplifier reference design board featuring:
  - Si8241 ISOdriver
  - Si8610 Digital Isolator

### 2. Introduction

This User's Guide discusses the Silicon Labs Audio Class D amplifier reference design, a stereo, two-state, half-bridge Class D amplifier leveraging the performance advantages of the Si8241 ISOdriver. This two-channel Class D Audio Amplifier delivers 120 W per channel into 8  $\Omega$ , while enabling < 0.02% THD at 60 W and > 95 dB SNR.

High-power audio systems are adopting digital audio technology and evolving toward lower-power, “green” products that meet Energy Star™ guidelines. Class-D audio systems have started penetrating the high-end markets where low noise, extremely good THD performance, and very high output power are required in consumer and industrial applications. The Si824x audio driver family consists of single-chip, isolated, Class-D gate drivers powering audio systems delivering from 30 W up to 1000 W of audio power.

Occasionally, a new IC is introduced that challenges the current technological hegemony. With features that make these products the perfect drivers for Class D amplification, the Silicon Labs Si8241/44 Audio Gate Drivers represent a new standard for the Class D amplifier industry. Based on Silicon Labs' proprietary isolation technology, the Si824x audio drivers incorporate input-to-output isolation that enables level-translation of signals without additional external circuits. The Si824x audio drivers feature adjustable dead-time control for achieving optimal THD, overlap protection that safeguards against shoot-through current damage, robust immunity to latch-up and high-voltage transients, and lower BOM costs and PCB footprints compared to non-isolated gate drive solutions. A typical audio driver application using the Si824x is shown in Figure 1. For more information on the Si824x audio driver, refer to the Si824x data sheet at [www.silabs.com/products/audio](http://www.silabs.com/products/audio).

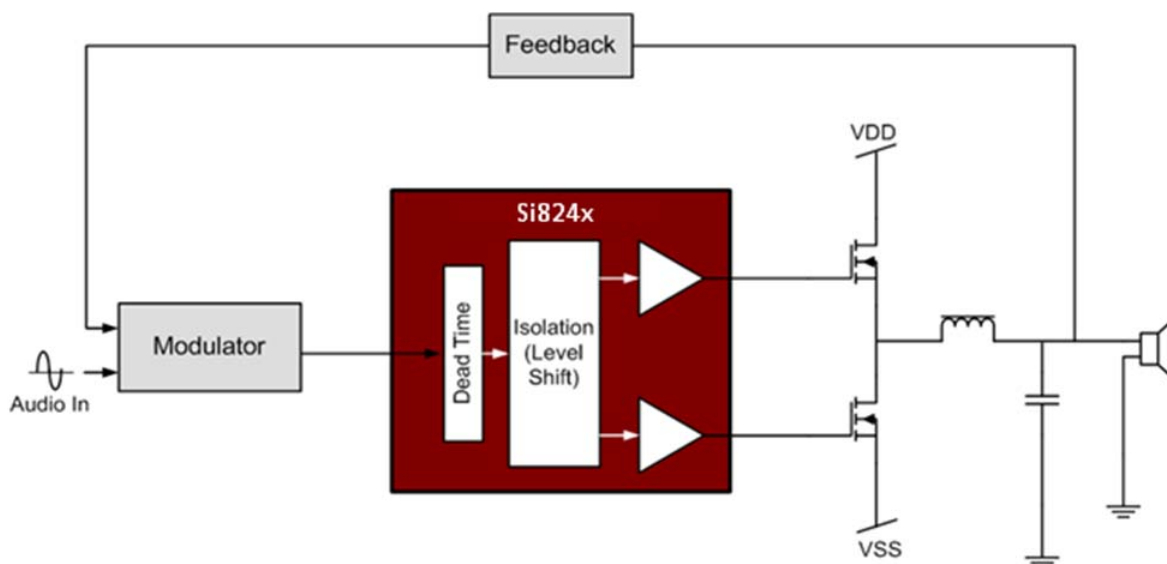

Figure 1. Si824x-Based Class D Audio Driver Block Diagram



# Si824xClassD-KIT

## 3. Hardware Overview and Demo

### 3.1. Reference Design Board Architecture

The Silicon Labs Class D reference design architecture uses a phase-shift, self-oscillating modulation approach that is capable of achieving far greater signal-to-noise ratio than clock driven amplifiers (see Figure 2). This self-oscillating implementation eliminates the circuitry necessary to generate the triangle waveform. To keep the circuit as simple as possible, a two-state, half-bridge is implemented and exemplifies the benefits of using the Si8241 Audio Gate Driver.

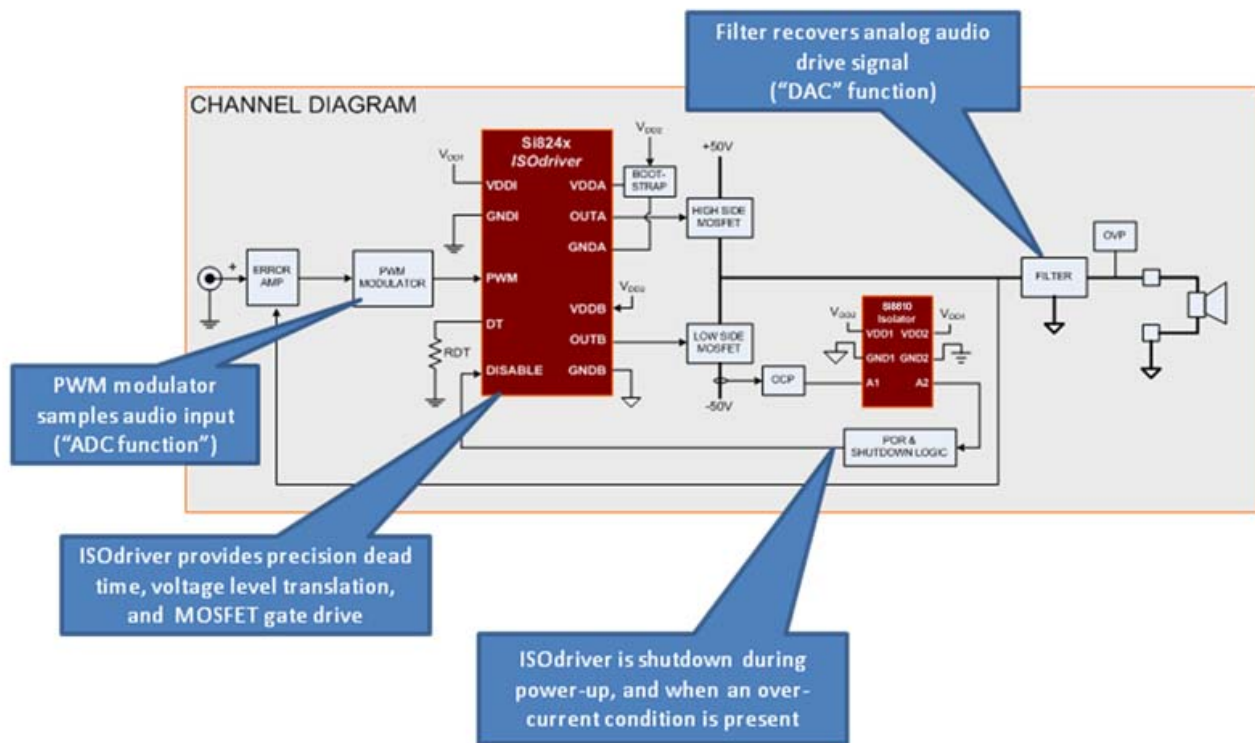

Figure 2. Block Diagram of Si8241-Based Class D Amplifier

### 3.2. Setting up the Class D Amplifier

Figure 3 illustrates connections necessary to power the Class D amplifier. The user will need the following items:

- MP3 player (or equivalent line out audio source)
- Audio Y-Cable (stereo male to Dual RCA Male)
- $\pm 50$  V supply capable of sourcing 3 Amps
- $\pm 12$  V supply capable of sourcing 500 mA
- Two speakers (up to 150 W)
- Silicon Labs Class D reference design board

#### Warning:

1. To protect the amplifier and speakers, before turning on the main power (the  $\pm 50$  V supplies) to the amplifier, ensure that the audio source from the MP3 player has its volume set to the lowest possible level.
2. The L-bracket can heat up to 80 °C and should be handled with care.

## 3.3. Powering up the Class D Amplifier and Playing Music

After the audio source, audio Y-cable, supplies, and speakers have been properly connected as shown in Figure 3.

1. Turn on the  $\pm 12$  V supplies.
2. Then, turn on the  $\pm 50$  V supplies. Notice that LED1 should turn on for about 1 sec and then turn off. This on and off sequence clears any overcurrent protection faults and indicates to the user that the amplifier is ready to amplify the audio input signal. If the LED does not turn off after about 1 sec, cycle on and off the  $\pm 12$  V supplies. Repeat this step until the LED turns off. If the LED never turns off, the board has probably been damaged.
3. With the audio source's volume turned down to its lowest output level, start the audio source.
4. Adjust the volume to the desired listening level.
5. Enjoy your music!

**Note:** If the power being delivered to the speakers is too great, the overcurrent protection circuitry will trip and shut off audio to the speakers, protecting the amplifier. LED1 will turn on in this condition. See "4.4. Overcurrent Protection" on page 4 for more details on clearing this fault condition.

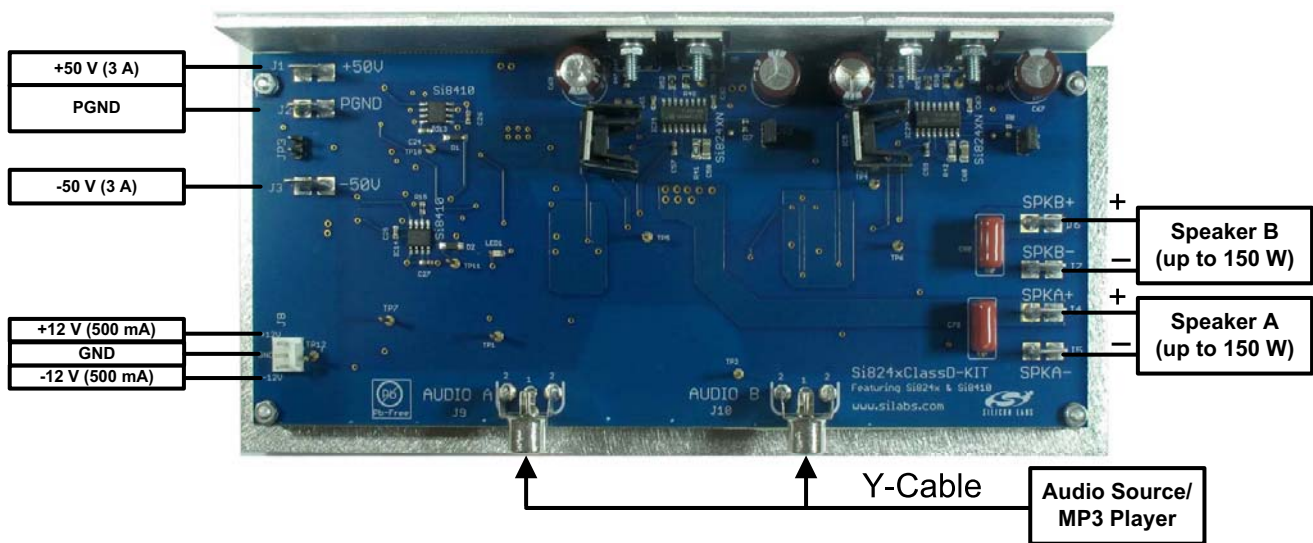

Figure 3. Si824xClassD-KIT (Top View)

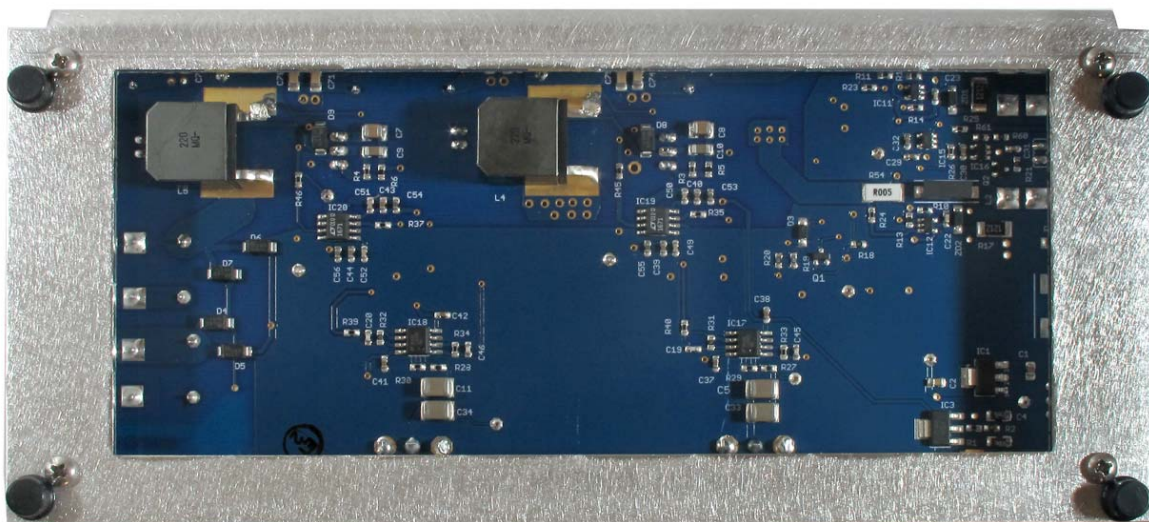

Figure 4. Si824xClassD-KIT (Bottom View)

# Si824xClassD-KIT

## 4. Additional Features and Architectural Considerations

### 4.1. Gate Drive Structure

Figure 5 illustrates the ease with which the Si8241 can drive a two-state, half-bridge class D amplifier. The boot supply tied to D1 must be 12 V higher than the  $-50$  V reference ( $-38$  V) so that the MOSFETs each have a 12 V drive signal. The closed loop gain of the Silicon Labs Class D reference design is implemented such that approximately 1 V<sub>pp</sub> input will yield full output power into an 8  $\Omega$  load.

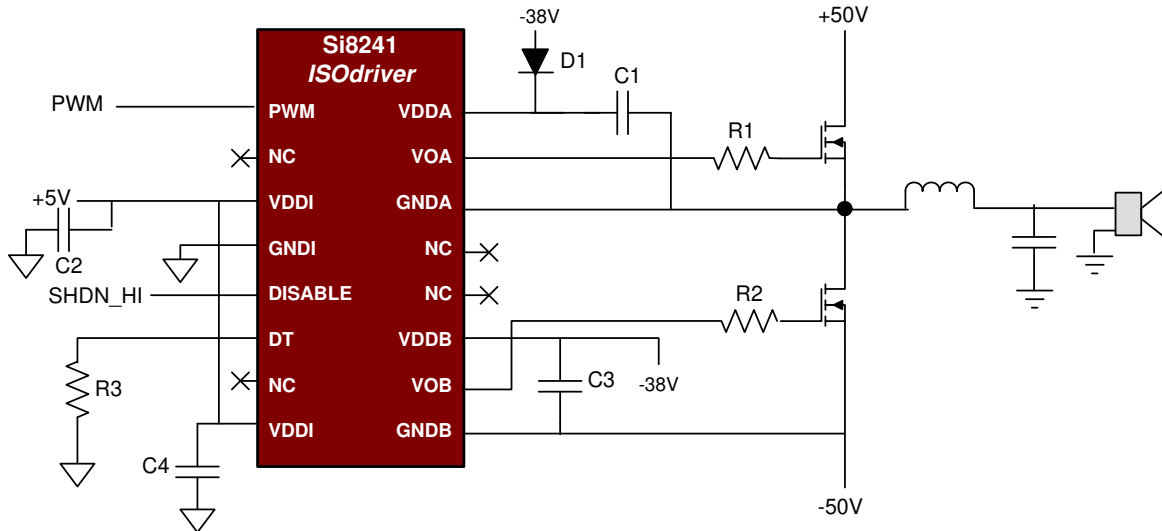

Figure 5. Si8241 Audio Gate Driver Gate Drive Circuit

### 4.2. Self Oscillation

The amplifier is self-oscillating, enabling its signal-to-noise ratio to far exceed that of a clock driven system. The main mechanism for this is the delta-sigma effect of shifting in-band noise to a much higher out-of-band frequency. The amplifier is a basic, phase-shift type, which has significant advantages over an amplifier running as a hysteretic oscillator. There is a pole in the forward path  $G(s)$  and a pole in the feedback path  $H(s)$ . The  $180^\circ$  phase shift, coupled with the transport delay, yields an oscillation frequency of nearly 500 kHz. The frequency of oscillation is set by capacitors in each audio channel where reducing capacitance value increases oscillation frequency. Tight tolerance capacitors are used to keep the channel frequencies as close to each other as possible.

### 4.3. Heat Sink L-Bracket

The amplifier design includes an L-bracket to sink excess heat from the power transistors. At full power, the L-bracket's temperature should increase to no higher than 80 degrees Celsius.

### 4.4. Overcurrent Protection

The Silicon Labs Class D reference design has an overcurrent protection circuit consisting of a low-power comparator floating off the upper and lower bus voltages. The upper rail circuit is shown in Figure 6 and is duplicated on the lower rail. It monitors the current flowing through the 0.005  $\Omega$  resistor (RSENSE). Zener diode D1 and resistor R4 supply power to the comparator and the Silicon Labs Si8610 digital isolator. The Si8610 performs the necessary level shifting to interface to the shutdown circuitry. The circuit is set to trip at roughly a 20 A fault, usually caused by a short-circuit across the speaker terminals or a large overdrive signal at the audio inputs. Note the upper and lower overcurrent circuits are ORed together through a pair of diodes and sent to the reset control circuit. The normally low Si8610 A1 input is driven high upon detection of an overcurrent condition and asserts the SHUTDOWN signal, forcing the reset controller to assert a reset signal, momentarily halting amplifier operation. The reset control circuit attempts restart after one second, and, if the fault is still present, again cycles reset in "hiccup" mode with a frequency of one second. This process continues until the fault is removed. Overcurrent protection can be removed by uninstalling JP1 and JP2.

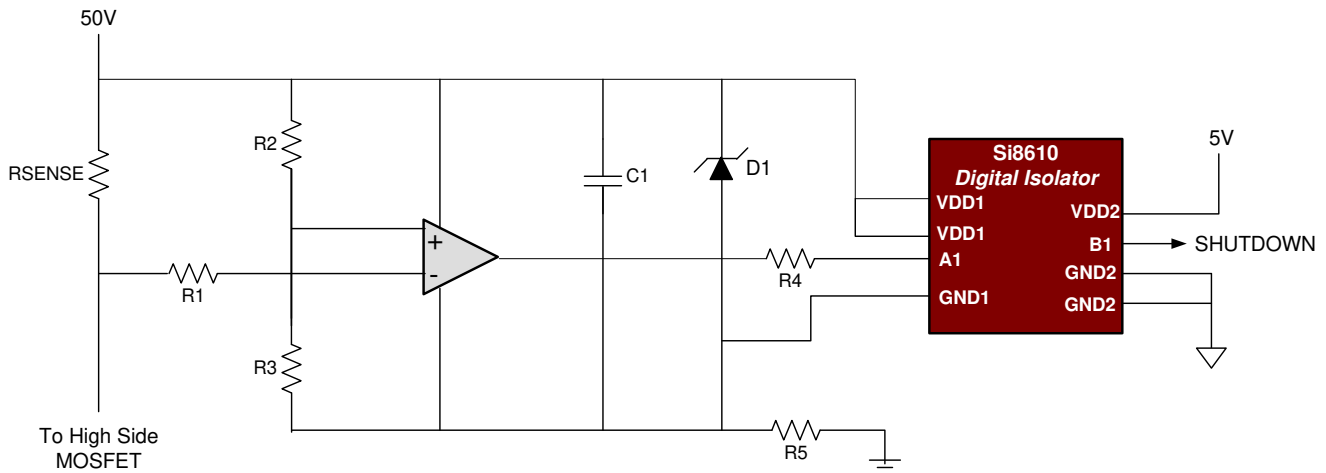

**Figure 6. Over Current Protection Circuit**

## 4.5. Undervoltage Protection

The undervoltage protection comparator monitors the positive bus voltage and releases the undervoltage lockout when the voltage is above 37 V. The amplifier starts up after a one-second delay. Note that the red LED remains lit when the amplifier is in shutdown mode and turns off when the amplifier is enabled.

## 4.6. Other Features

A protection circuit jumper (JP 3) option is included that allows the amplifier to be manually shut down. This jumper can be replaced with a switch or other control circuit, allowing the amplifier to be muted. The one-second undervoltage lockout delay allows the op-amps and comparator to settle before the shut-down circuit is released, thereby preventing speaker pops. To aid in system performance evaluation, there are individual jumper options (JP1 and JP2) on each channel that allow the user to enable or disable each channel independently of the other.

## 4.7. Performance

The Silicon Labs Class D reference design board was tested for THD + N, SNR, DFD, and IFD with an Audio Precision analyzer. During these tests, the main power (the  $\pm 50$  V supplies) used a TR180 from Hypex electronics (a low-noise supply) to maximize the amplifier's measured performance.

# Si824xClassD-KIT

## 5. Si8241-Based Class D Amplifier Connection Description

The Si8241-based Class D Amplifier has two Si8241 ISOdrivers and two Si8610 digital isolators installed. Refer to Figure 7 for the locations of the various I/O connectors and major components. Relevant user connection points are detailed below.

- |        |          |  |
|--------|----------|--|
| ■ J1   | +50 V    | Positive Input Power: Input power connection +50 V, 3 A. |
| ■ J2   | PGND     | Power Ground Return, 0 V.                                |
| ■ J3   | -50 V    | Negative Input Power: Input power connection -50 V, 3 A. |
| ■ J4   | SPKA+    | Speaker A positive terminal                              |
| ■ J5   | SPKA-    | Speaker A negative terminal                              |
| ■ J6   | SPKB+    | Speaker B positive terminal                              |
| ■ J7   | SPKB-    | Speaker B negative terminal                              |
| ■ J8   | VBIAS    | ±12 V Bias supply connector (500 mA)                     |
| ■ J9   | AUDIO A  | RCA input female connector channel A                     |
| ■ J10  | AUDTIO B | RCA input female connector channel B                     |
| ■ JP1  | OCPCISA  | Over current protection disable channel A channel        |
| ■ JP2  | OCPCISB  | Over current protection disable channel B channel        |
| ■ JP3  | MUTE     | Amplifier Mute or manual shut down                       |
| ■ LED1 | FAULT    | Over current protection fault indicator LED              |

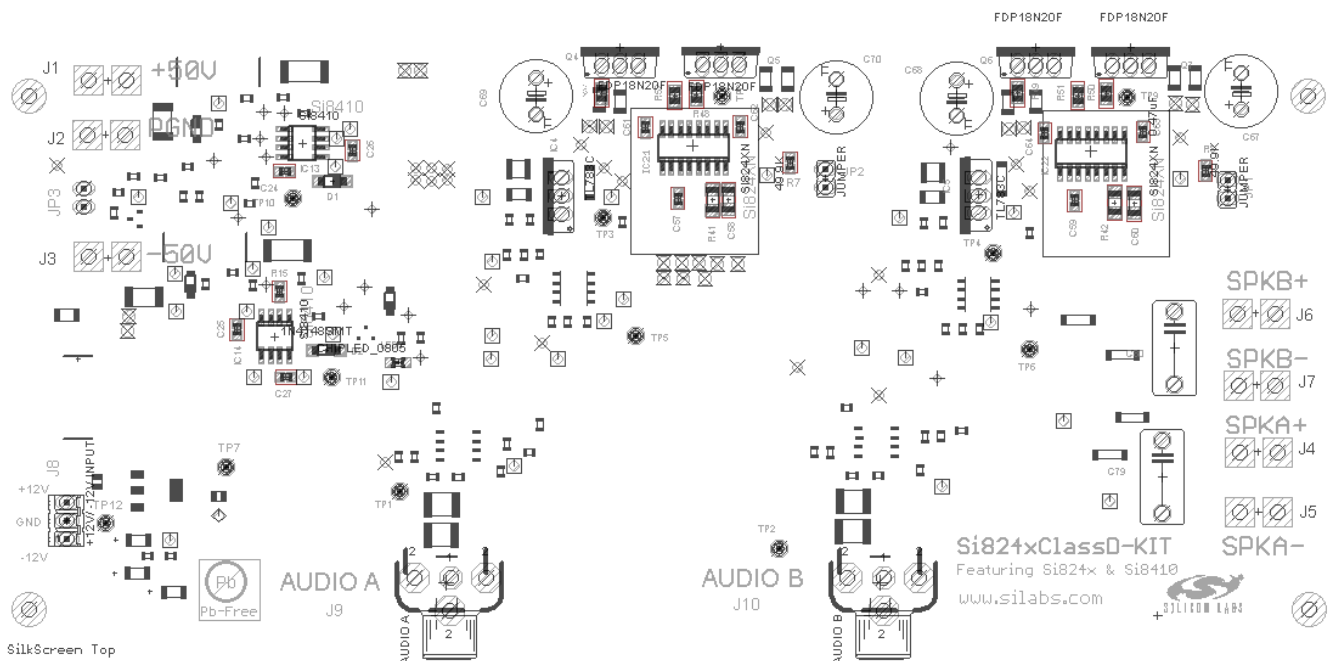

Figure 7. Si8241 Si8241-Based Class D Amplifier Silkscreen

### 5.1. Voltage and Current Sense Test Points

The Si824x Class D Audio Amplifier reference design has several test points. These test points correspond to the respective pins on the Si8241, Si8610 as well as other useful inspection points. See “6. Schematics” for more details.



## 6. Schematics

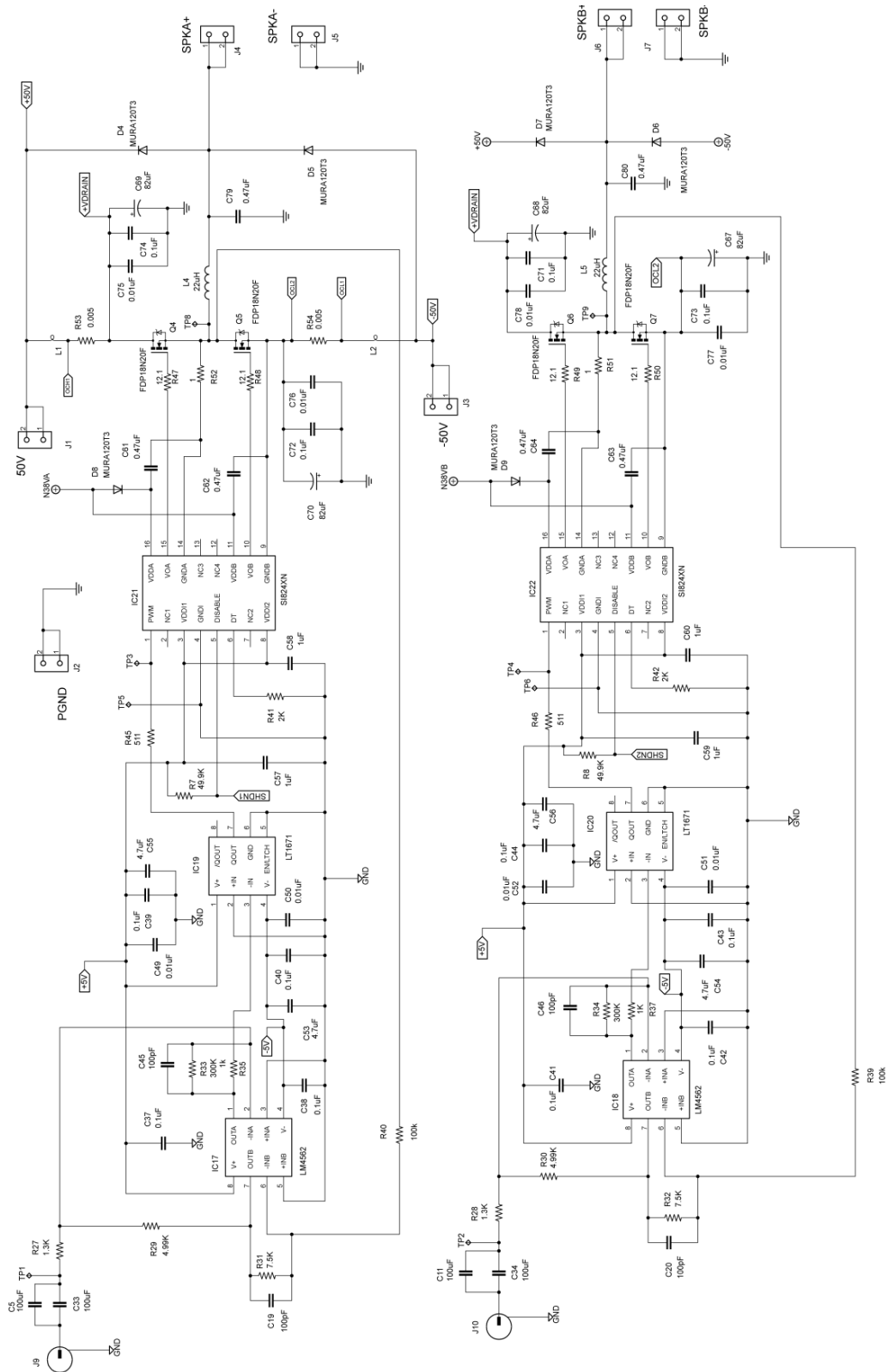

Figure 8. Si824x Class D Audio Amplifier Reference Design Schematic (1 of 2)



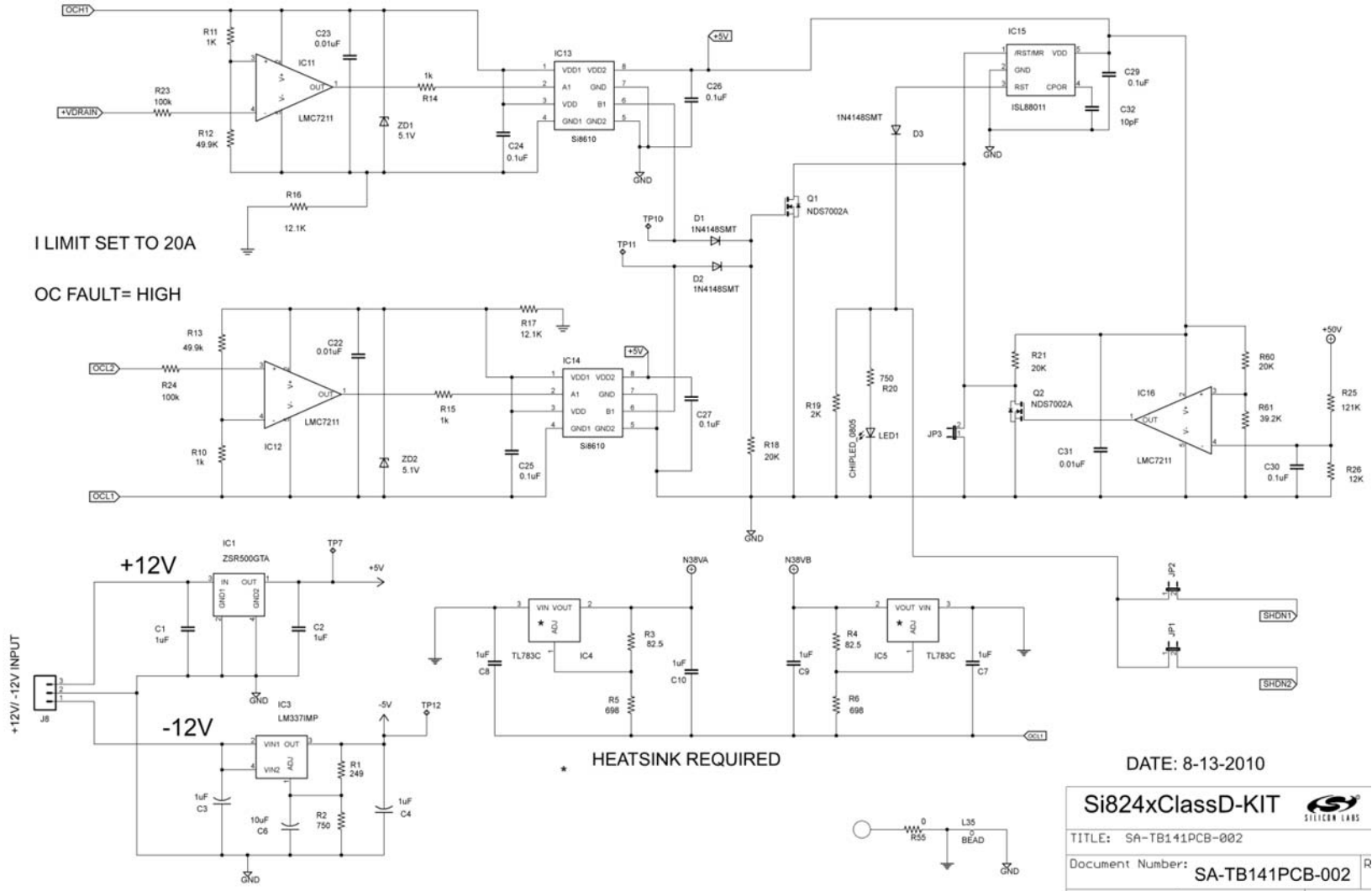

Figure 9. Si824x Class D Audio Amplifier Reference Design Schematic (2 of 2)

## 7. Bill of Materials

Table 1. Si824x Class D Audio Amplifier Reference Design Bill of Materials

Qty	Ref	Description	Mfr. Part Number	Mfr	Digikey Part Number
2	C1, C2	1 $\mu$ F, 25 V, X5R, 0805 Ceramic Capacitor	08053D105KAT2A	AVX	478-1409-6-ND
2	C3, C4	1 $\mu$ F, 16 V, 3216 Tantalum Capacitor	T491A105M016AT	Kemet	399-3681-6-ND
14	C24–C27, C29, C30, C37–C44	0.1 $\mu$ F, 50 V, X7R, 0603 Ceramic Capacitor	GRM188R71H104- KA93D	Murata	490-1519-6-ND
1	C6	10 $\mu$ F, 10 V, 3216 Tantalum Capacitor	T491A106M010AT	Kemet	399-3686-6-ND
2	C7,C8	1 $\mu$ F, 100 V, X7R, 1210 Ceramic Capacitor	GRM32ER72A105- KA01L	Murata	490-1857-1-ND
4	C9, C10, C58, C60	1 $\mu$ F, 25 V, X5R, 1206 Ceramic Capacitor	GRM319R61E105K C36D	Murata	490-1807-6-ND
2	C57, C59	1 $\mu$ F, 10 V, X5R, 0603 Ceramic Capacitor	GRM188R61A105- KA61D	Murata	490-1543-6-ND
7	C22, C23, C31, C49–C52	0.01 $\mu$ F, 50 V, X7R, 0603 Ceramic Capacitor	06035C103KAT2A	AVX	478-1227-6-ND
1	C32	10 pF, 50 V, COG, 0603 Ceramic Capacitor	06035A100JAT2A	AVX	478-1163-6-ND
4	C5, C11, C33, C34	100 $\mu$ F, 6.3 V, X5R, 1812 Ceramic Capacitor	C4532X5R0J107M	TDK	445-1413-2-ND
4	C19, C20, C45, C46	100 pF, 50 V, COG, 0603 Ceramic Capacitor	GRM1885C1H101- JA01D	Murata	490-1427-6-ND
4	C53–C56	4.7 $\mu$ F, 6.3 V, X5R, 0603 Ceramic Capacitor	06036D475MAT2A	AVX	478-2582-6-ND
4	C61–C64	0.47 $\mu$ F, 16 V, X5R, 0603 Ceramic Capacitor	C0603X7R160- 474MNE	AVX	478-1248-6-ND

# Si824xClassD-KIT

**Table 1. Si824x Class D Audio Amplifier Reference Design Bill of Materials (Continued)**

Qty	Ref	Description	Mfr. Part Number	Mfr	Digikey Part Number
4	C67-C70	82 $\mu$ F, 63 V, KZE Series Electrolytic Cap	EKZE630ESS820M JC5S	Chemi-Con	565-1721-ND
4	C71-C74	0.1 $\mu$ F, 100 V, X7R, 1206 Ceramic Capacitor	12061C104MAT2A	AVX	478-3786-6-ND
4	C75-C78	0.01 $\mu$ F, 100 V, COG, 1206 Ceramic Capacitor	12061C103JAT2A	AVX	478-3783-6-ND
2	C79, C80	0.47 $\mu$ F, 250 V Film Capacitor	ECQ-E2474KB	Panasonic ECG	P10975-ND
3	D1-D3	100 V 150 mA SOD123 Diode	1N4148W-13-F	Diodes Inc.	1N4148W-13-FDIDKR-ND
6	D4-D9	Fast Recovery 200 V 2 A Diode SMA	MURA120T3G	On Semi	MURA120T3GOSCT-ND
2	ZD1, ZD2	Diode Zener 500 mW 5.1 V SOD-123	MMSZ4689-TP	Micro Commercial Co.	MMSZ4689-TPMSCT-ND
1	IC1	IC Voltage Reg 5.0 V 200 mA SOT223	ZSR500GTA	ZETEX	ZSR500GCT-ND
1	IC3	Adjustable Negative Regulators SOT-223	LM337IMP	National Semi	LM337IMPDKR-ND
2	IC4, IC5	High-Voltage Adjustable Regulator TO220	TL783CKCSE3	TI	296-20687-5-ND
3	IC11, IC12, IC16	CMOS Comparator SOT23-5	LMC7211BIM5/ NOPB	National Semi	LMC7211BIM5CT-ND
2	IC13, IC14	Single Channel Digital Isolator SOIC8	Si8610BB-B-IS	Silabs	
1	IC15	Voltage Supervisor with Adjustable Power-on Reset SOT23-5	ISL88011IH531Z- TK	Intersil	ISL88011IH531Z-TKDKR-ND
2	IC17, IC18	IC Opamp Audio Ster AB 8SOIC	LM4562MA/NOPB	National Semi	LM4562MA-ND

**Table 1. Si824x Class D Audio Amplifier Reference Design Bill of Materials (Continued)**

Qty	Ref	Description	Mfr. Part Number	Mfr	Digikey Part Number
2	IC19, IC20	IC Comp Grnd-sensing LowPwr 8SOIC	LT1671CS8#PBF	Linear Tech	LT1671CS8#PBF-ND
2	IC21, IC22	Isodriver Narrow Body	Si8241BB-B-IS1	Silabs	
7	J1–J7	1/4 inch-Faston	62409-1	Tyco Electronics	A24742-ND
1	J8	3 Pin Conn Header	22-23-2031	Molex Inc.	WM4201-ND
2	J9, J10	Conn RCA Jack Metal R/A YEL PCB	RCJ-014	CUI Inc.	CP-1403-ND
3	JP1–JP3	Jumper	TSW-102-07-T-S	Samtec	SAM1035-02-ND
3	L1, L2, L35	Ferrite Bead	2773021447	Fair-Rite	
2	L4, L5	22 $\mu$ H, 7 A, 8.3 m $\Omega$ Inductor	7G14A-220M-R	Sagami	
1	LED1	LED Chip LED 645NM Red Diff 0805	LH R974-LP-1-0-20-R18	Osram	475-1415-6-ND
2	Q1, Q2	MOSFET N-CH 60 V 280 mA SOT-23	NDS7002A	Fairchild Semi	NDS7002ACT-ND
4	Q4–Q7	200V, 18A N-Channel MOSFET	FDP18N20F	Fairchild Semi	FDP18N20F-ND
1	R1	249 $\Omega$ , 0603 1% SMT Resistor	ERJ-3EKF2490V	Panasonic ECG	P249HDKR-ND
2	R2, R20	750 $\Omega$ , 0603 1% SMT Resistor	ERJ-3EKF7500V	Panasonic ECG	P750HCT-ND
2	R3, R4	82.5 $\Omega$ , 0603 1% SMT Resistor	ERJ-3EKF82R5V	Panasonic ECG	P82.5HDKR-ND
2	R5, R6	698 $\Omega$ , 0603 1% SMT Resistor	ERJ-3EKF6980V	Panasonic ECG	P698HDKR-ND
4	R7, R8, R12, R13	49.9 k $\Omega$ , 0603 1% SMT Resistor	ERJ-3EKF4992V	Panasonic ECG	P49.9KHCT-ND
1	R26	12 k $\Omega$ , 0603 1% SMT Resistor	ERJ-3EKF1202V	Panasonic ECG	P12.0KHCT-ND
6	R10, R11, R14, R15, R35, R37	1 k $\Omega$ , 0603 1% SMT Resistor	ERJ-3EKF1001V	Panasonic ECG	P1.00KHCT-ND



# Si824xClassD-KIT

**Table 1. Si824x Class D Audio Amplifier Reference Design Bill of Materials (Continued)**

Qty	Ref	Description	Mfr. Part Number	Mfr	Digikey Part Number
2	R16, R17	12.1 k $\Omega$ , 2010 1% SMT Resistor	ERJ-12SF1212U	Panasonic ECG	P12.1KACCT-ND
3	R18, R21, R60	20 k $\Omega$ , 0603 1% SMT Resistor	ERJ-3EKF2002V	Panasonic ECG	P20.0KHCT-ND
2	R29, R30	4.99 k $\Omega$ , 0603 1% SMT Resistor	ERJ-3EKF4991V	Panasonic ECG	P4.99KHCT-ND
4	R23, R24, R39, R40	100 k $\Omega$ , 0603 1% SMT Resistor	ERJ-3EKF1003V	Panasonic ECG	P100KHCT-ND
1	R25	121 k $\Omega$ , 0603 1% SMT Resistor	ERJ-3EKF1213V	Panasonic ECG	P121KHCT-ND
2	R27, R28	1.3 k $\Omega$ , 0603 1% SMT Resistor	ERJ-3EKF1301V	Panasonic ECG	P1.30KHCT-ND
2	R31, R32	7.5 k $\Omega$ , 0603 1% SMT Resistor	ERJ-3EKF7501V	Panasonic ECG	P7.50KHCT-ND
2	R33, R34	300 k $\Omega$ , 0603 1% SMT Resistor	ERJ-3EKF3003V	Panasonic ECG	P300KHCT-ND
3	R19, R41, R42	2 k $\Omega$ , 0603 1% SMT Resistor	ERJ-3EKF2001V	Panasonic ECG	P2.00KHCT-ND
2	R45, R46	511 $\Omega$ , 0603 1% SMT Resistor	ERJ-3EKF5110V	Panasonic ECG	P511HCT-ND
4	R47–R50	12.1 $\Omega$ , 0805 1% SMT Resistor	ERJ-6ENF12R1V	Panasonic ECG	P12.1CCT-ND
2	R51, R52	1 $\Omega$ , 0805 1% SMT Resistor	RC0805FR-071RL	Yageo	311-1.00CRCT-ND
2	R53, R54	0.005 $\Omega$ , 3264 1% SMT Resistor	MCS3264R005FE	Panasonic ECG	MCS3264R005FERCT-ND
1	R55	0 $\Omega$ , 1206 1% SMT Resistor	ERJ-8GEY0R00V	Panasonic ECG	P0.0ECT-ND
1	R61	39.2 k $\Omega$ 0603 1% SMT Resistor	ERJ-3EKF3922V	Panasonic ECG	P39.2KHCT-ND
2	HS1	Heatsink TO-220 5W BLK	576802B00000G	AAVID Thermalloy	HS121-ND
12	TP1-TP12	Test Pad	3103-2-00-21-00-00-08-0	MILL-MAX MAN.	ED5052-ND
4	Shoulder Washer	Washer/bushing #4 X .031"L NYLON	3049	Keystone	3049-ND

**Table 1. Si824x Class D Audio Amplifier Reference Design Bill of Materials (Continued)**

Qty	Ref	Description	Mfr. Part Number	Mfr	Digikey Part Number
4	Insulator	Insulator Mica .860X.520" .141" TO-220	4672	Keystone	4672K-ND
4	Screw	Hdwr Mtg Screw TO- 220CASE 4/40 THR 1PC	4690	Keystone	4690K-ND
4	Screw	Hdwr Mtg Screw 1/ 4" 4/40 , PCB L- Bracket Mount	9900	Keystone	9900K-ND
4	Lock Washer	Hdwr Mtg Lock- washer Plastic 2PC	4693	Keystone	4693K-ND
4	Nut	Hdwr Mtg Nut 4/40 Thread 2PC	4694	Keystone	4694K-ND
	Heat Compound	Heat Trans Compound Silicone	860-150G	MG Chemicals	473-1097-ND
4	Standoff	Stdoff Hex M/F 4-40 .375"L Alum	8400	Keystone	8400K-ND
1	HTSNK	L Bracket Heat Sink	SIHS-1	Red River PRC MFG	
4	Bumpons, Feet, Pads, Grips	Bumpon Cylindrical .312X.215 BLK	SJ61A6	3M	SJ5744-0-ND
7	J1-J7	Conn Fast Recept 18-22 AWG .250	2-520264-2	Tyco Electronics	A27821-ND
2	JP1, JP2 Shorting Jumper	Conn Jumper Shorting Gold Flash	SPC02SYAN	Sullins Connector Solutions	S9001-ND

# Si824xClassD-KIT

---

## 8. Ordering Guide

Ordering Part Number	Type
Si824xClassD-KIT	Audio Class D Amplifier reference design kit using Si8241BB-B-IS1.

## DOCUMENT CHANGE LIST

### Revision 0.1 to Revision 0.2

- Updated Table 1, “Si824x Class D Audio Amplifier Reference Design Bill of Materials,” on page 9.

### Revision 0.2 to Revision 0.3

- Replaced Si8410 with Si8610.



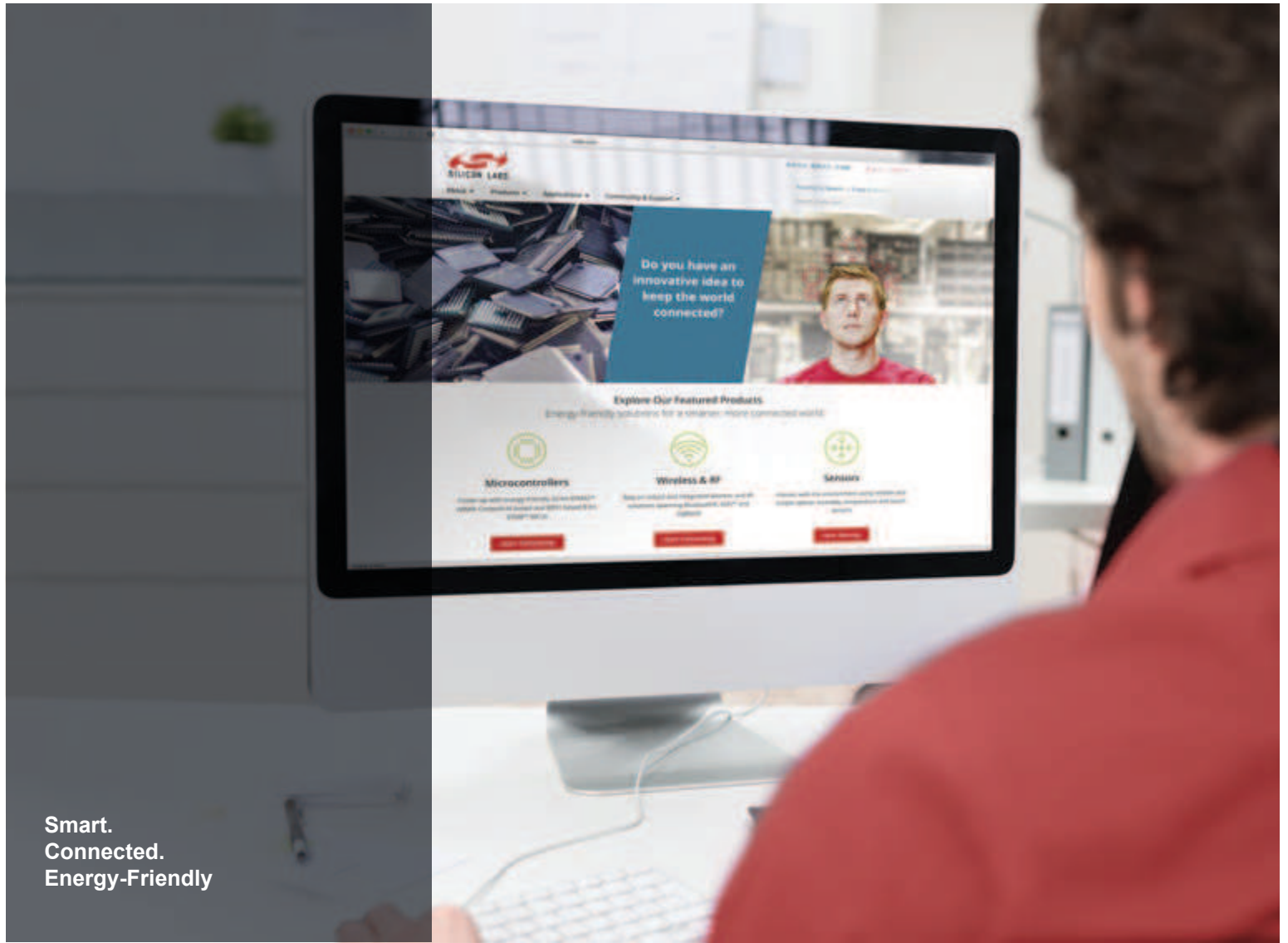

Smart.  
Connected.  
Energy-Friendly



**Products**  
[www.silabs.com/products](http://www.silabs.com/products)

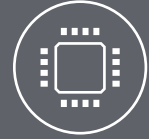

**Quality**  
[www.silabs.com/quality](http://www.silabs.com/quality)



**Support and Community**  
[community.silabs.com](http://community.silabs.com)

**Disclaimer**  
Silicon Laboratories intends to provide customers with the latest, accurate, and in-depth documentation of all peripherals and modules available for system and software implementers using or intending to use the Silicon Laboratories products. Characterization data, available modules and peripherals, memory sizes and memory addresses refer to each specific device, and "Typical" parameters provided can and do vary in different applications. Application examples described herein are for illustrative purposes only. Silicon Laboratories reserves the right to make changes without further notice and limitation to product information, specifications, and descriptions herein, and does not give warranties as to the accuracy or completeness of the included information. Silicon Laboratories shall have no liability for the consequences of use of the information supplied herein. This document does not imply or express copyright licenses granted hereunder to design or fabricate any integrated circuits. The products are not designed or authorized to be used within any Life Support System without the specific written consent of Silicon Laboratories. A "Life Support System" is any product or system intended to support or sustain life and/or health, which, if it fails, can be reasonably expected to result in significant personal injury or death. Silicon Laboratories products are not designed or authorized for military applications. Silicon Laboratories products shall under no circumstances be used in weapons of mass destruction including (but not limited to) nuclear, biological or chemical weapons, or missiles capable of delivering such weapons.

**Trademark Information**  
Silicon Laboratories Inc.®, Silicon Laboratories®, Silicon Labs®, SiLabs® and the Silicon Labs logo®, Bluegiga®, Bluegiga Logo®, Clockbuilder®, CMEMS®, DSPLL®, EFM®, EFM32®, EFR®, Ember®, Energy Micro, Energy Micro logo and combinations thereof, "the world's most energy friendly microcontrollers™", Ember®, EZLink®, EZRadio®, EZRadioPRO®, Gecko®, ISOModem®, Precision32®, ProSLIC®, Simplicity Studio®, SiPHY®, Telegesis, the Telegesis Logo®, USBXpress® and others are trademarks or registered trademarks of Silicon Laboratories Inc. ARM, CORTEX, Cortex-M3 and THUMB are trademarks or registered trademarks of ARM Holdings. Keil is a registered trademark of ARM Limited. All other products or brand names mentioned herein are trademarks of their respective holders.



Silicon Laboratories Inc.  
400 West Cesar Chavez  
Austin, TX 78701  
USA  
<http://www.silabs.com>