



Chipsmall Limited consists of a professional team with an average of over 10 year of expertise in the distribution of electronic components. Based in Hongkong, we have already established firm and mutual-benefit business relationships with customers from,Europe,America and south Asia,supplying obsolete and hard-to-find components to meet their specific needs.

With the principle of “Quality Parts,Customers Priority,Honest Operation,and Considerate Service”,our business mainly focus on the distribution of electronic components. Line cards we deal with include Microchip,ALPS,ROHM,Xilinx,Pulse,ON,Everlight and Freescale. Main products comprise IC,Modules,Potentiometer,IC Socket,Relay,Connector.Our parts cover such applications as commercial,industrial, and automotives areas.

We are looking forward to setting up business relationship with you and hope to provide you with the best service and solution. Let us make a better world for our industry!



## Contact us

Tel: +86-755-8981 8866 Fax: +86-755-8427 6832

Email & Skype: info@chipsmall.com Web: www.chipsmall.com

Address: A1208, Overseas Decoration Building, #122 Zhenhua RD., Futian, Shenzhen, China



---

## Si82XX EVALUATION BOARD USER'S GUIDE

---

### 1. Introduction

The Si823x isolated driver family combines two independent isolated drivers into a single package. The Si8230/1/3/4 are high-side/low-side drivers, and the Si8232/5/6 are dual drivers. Versions with peak output currents of 0.5 A (Si8230/1/2) and 4.0 A (Si8233/4/5/6) are available. The Si8220/21 is a high-performance functional upgrade for opto-coupled drivers, such as the HCPL-3120 and the HPCL-0302 providing 2.5 A of peak output current. These ISOdrivers utilize Silicon Laboratories' proprietary silicon isolation technology, which provides a choice of 2.5, 3.75, or 5.0 kVrms withstand voltages. All drivers operate with a maximum output supply voltage of 24 V. High integration, low propagation delay, small installed size, flexibility, and cost-effectiveness make the family ideal for a wide range of isolated MOSFET/IGBT gate drive applications.

The Si82xx evaluation board allows designers to evaluate Silicon Lab's family of ISOdrivers. The boards come populated with 5 kVrms versions of the Si8220, Si8233, Si8234, and Si8235. The board includes land pads for common surface mount and through-hole packaged FET/IGBT power transistors. The board also includes patch area for additional prototyping that can be used to accommodate any load configuration a designer might need to evaluate. For more ISOdriver information, visit Silicon Labs web site at [www.silabs.com/isolation](http://www.silabs.com/isolation). The product data sheet and numerous application notes can be referenced to help facilitate designs.



# Si82xx-EVB UG

## 2. Kit Contents

The Si82xx Evaluation Kit contains the following items:

- Si82xx-based evaluation board (Si82xx-EVB) shown in Figure 1.
- Si8220, Opto-input, 2.5 A, 5 kV ISOdriver
- Si8233, 2-input, 4 A, 5 kV, High-Side/Low-Side ISOdriver
- Si8234, PWM-input, 4 A, 5 kV High-Side/Low-Side ISOdriver
- Si8235, 2-input, 4 A, 5 kV Dual ISOdriver

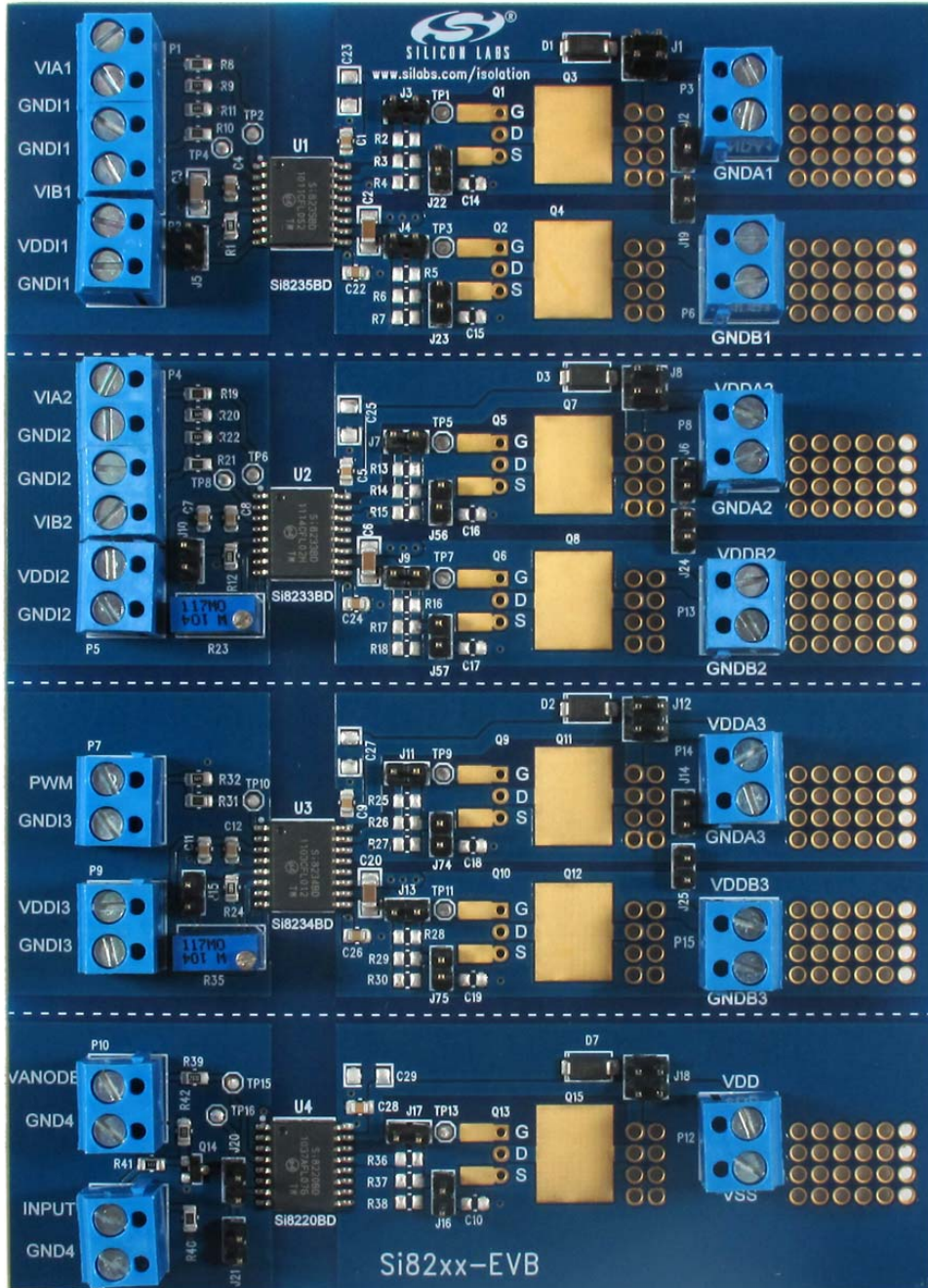

Figure 1. Si82xx Evaluation Board Overview

## 3. Si82xx ISOdriver Board Overview

The Si82xx evaluation board is populated with the following ISOdrivers:

- Si8220 in wide-body SOIC-16 package, opto-input, 2.5 A, 5 kV ISOdriver
- Si8233 in wide-body SOIC-16 package, 2-input, 4 A, 5 kV High-Side/Low-Side ISOdriver
- Si8234 in wide-body SOIC-16 package, PWM-input, 4 A, 5 kV High-Side/Low-Side ISOdriver
- Si8235 in wide-body SOIC-16 package, 2-input, 4 A, 5 kV Dual ISOdriver
- High-side and low-side land pads for surface mount packaged FET/IGBT power transistors (not populated)
- High-side and low-side land pads for through-hole packaged FET/IGBT power transistors (not populated)
- Patch area

The Si82xx board is four separate evaluation boards in one, with each section featuring a different ISOdriver (Si8220, Si8233, Si8234, or Si8235). Each section is isolated from the other sections and requires its own power supplies to power the given section's ISOdriver. Each section's ISOdriver is designed to be powered separately with input supplies for VDDI (5.5 V, 500 mA) and output supplies for VDDA, VDDB, or VDD up to 24 V. The user is expected to connect their desired drive-trane topology and load to the outputs of the appropriate ISOdriver and the patch area. Figure 2 shows a silkscreen overview of the board.

Please note the voltage rating for the prepopulated components in the Si82xx BOM section of this document before applying power to the ISOdriver and customer specific driver-trane. Applying a voltage to a component that is higher than its rating can cause permanent device damage. If the install components do not meet the user's requirements, these components need to be replaced before proceeding. Moreover, if a user wants to evaluate an ISOdriver in a wide-body package other than the ones populated, this can be accomplished by removing the footprint-compatible device installed on the evaluation board and replacing it with the desired footprint-compatible ISOdriver.

# Si82xx-EVB UG

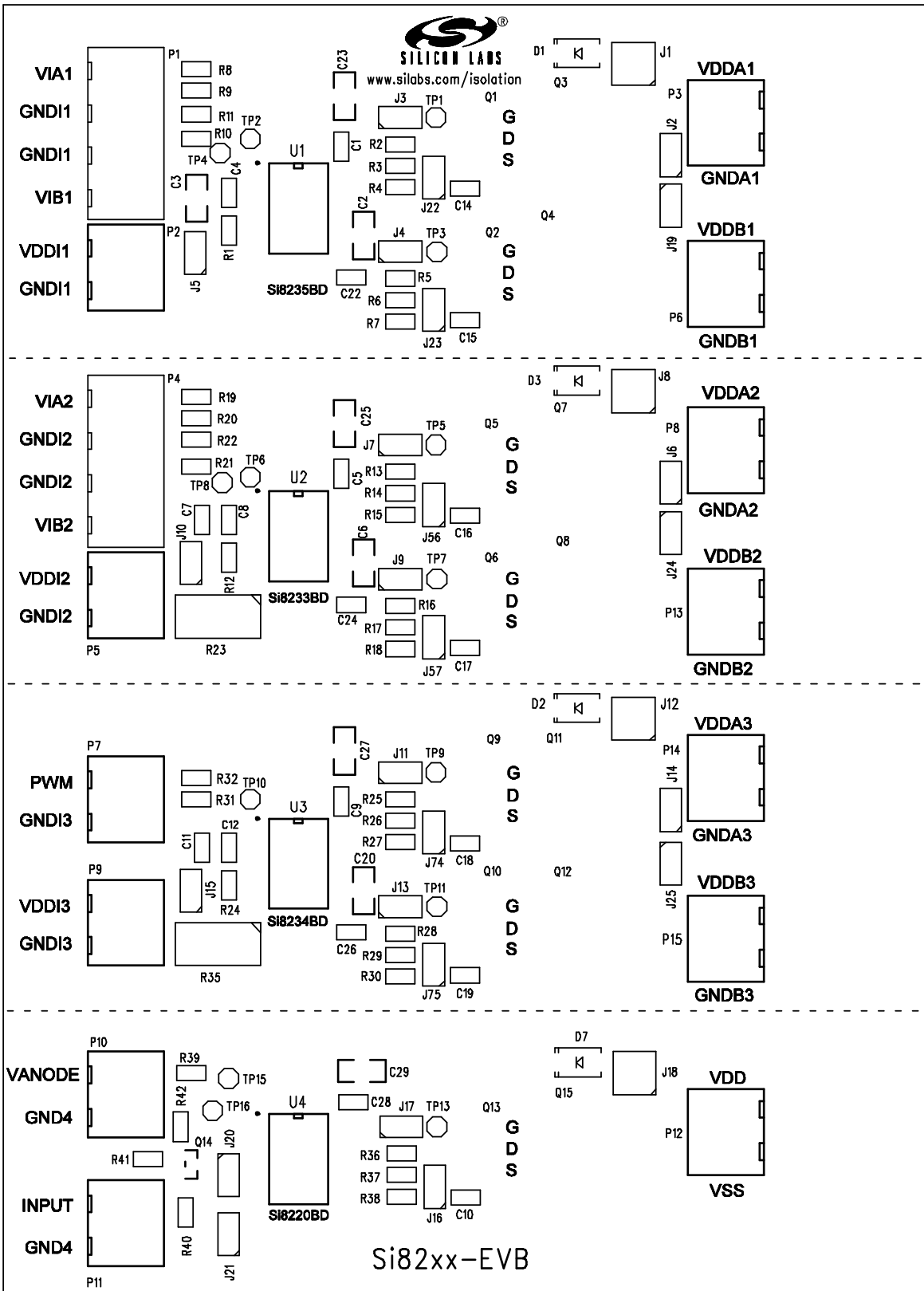

Figure 2. Si82xx Evaluation Board Silkscreen

### 3.1. Si82xx ISOdriver Board Test

Figure 3 illustrates the Si8234 with VDDI powered from 5 V and VDDA and VDDB powered from 15 V. A 10 kHz signal is applied to the Si8234's PWM input. As shown, the Si8234 transmits a 10 kHz signal to VOA and VOB (Channel 3 illustrates VOA output, and Channel 2 illustrates VOB output). Note that VOA and VOB are 180° out of phase, as would be expected of a PWM driver. In this setup, no drive-trane was connected to the outputs (VOA and VOB) of the Si8234. Nevertheless, the potentiometer, R35, can be adjusted to dynamically change the dead-time of the Si8234 if desired. Duplicating this setup is an excellent test to become familiar with the evaluation board. To repeat this test, perform the following steps:

1. Install a shunting jumper to J12 (Position 1, 2).
2. Install a shunting jumper to J14.
3. Install a shunting jumper to J11.
4. Install a shunting jumper to J13.
5. Connect a 5 Vp-p square wave to P7.
6. Connect a 5 V (100 mA) supply to P9.
7. Connect a 15 V (100 mA) supply to P14.
8. Connect a 15 V (100 mA) supply to P15.
9. Connect a scope probe to TP9 to view VOA.
10. Connect a scope probe to TP11 to view VOB.

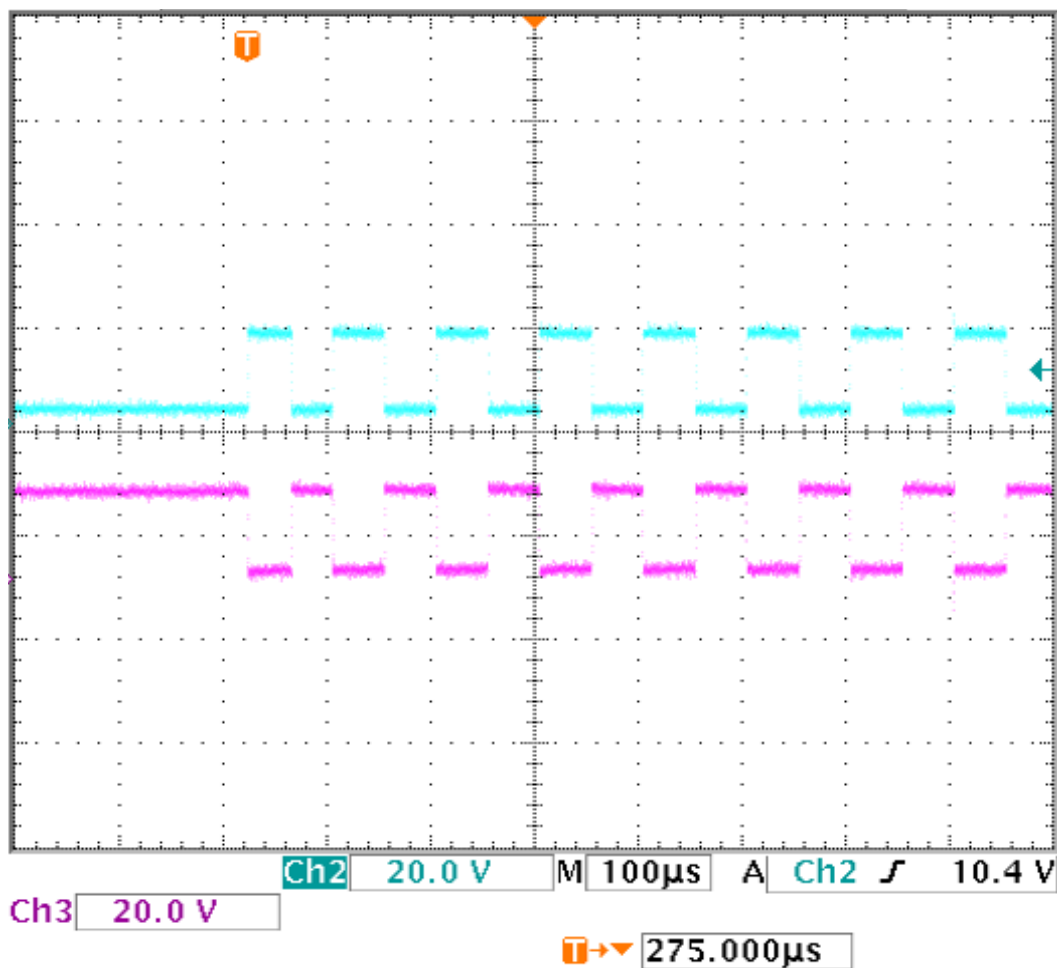

Figure 3. Si8234 PWM Outputs

## 4. Si82xx Evaluation Board Schematics

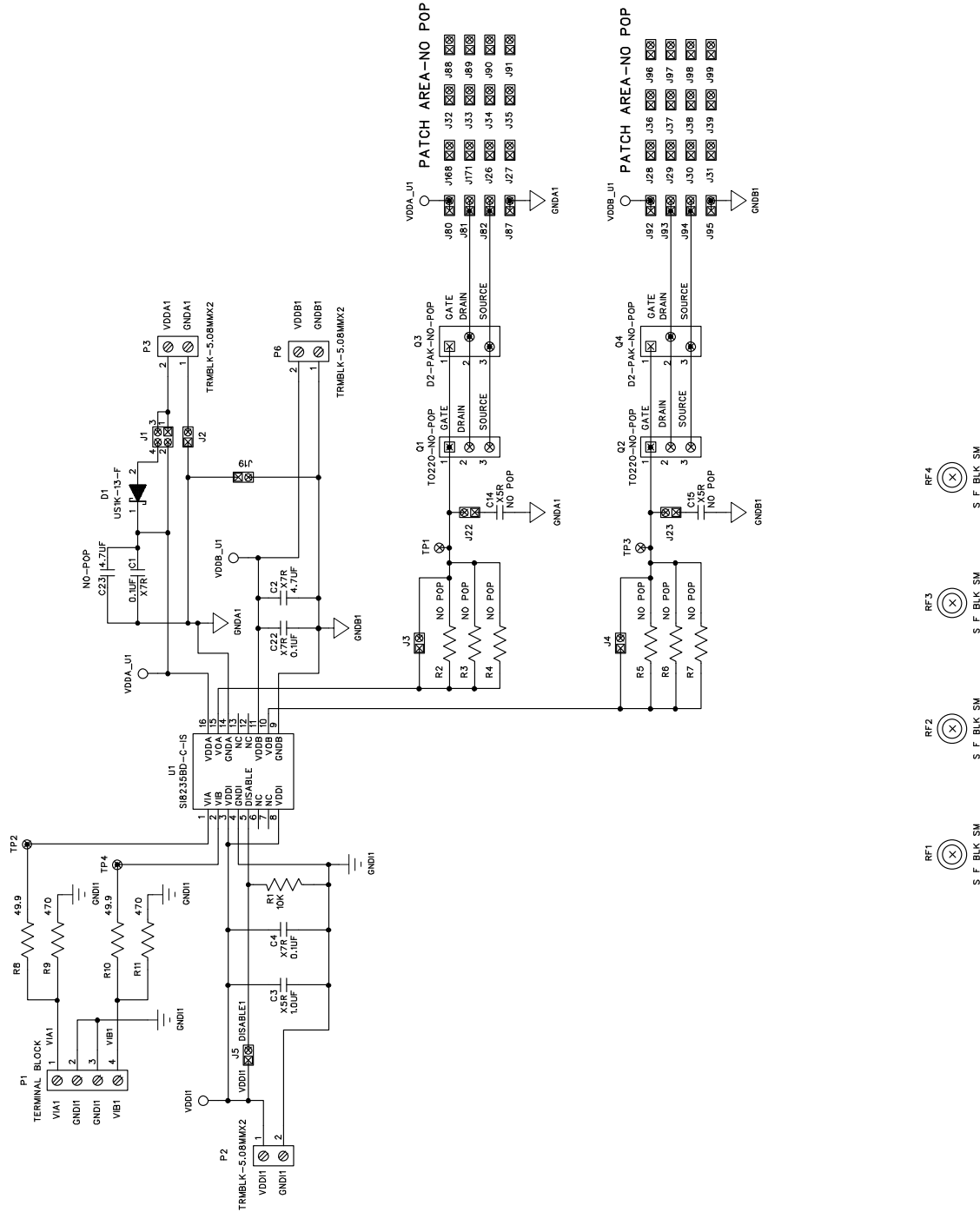

Figure 4. Si82xx Evaluation Board Schematic (1 of 4)

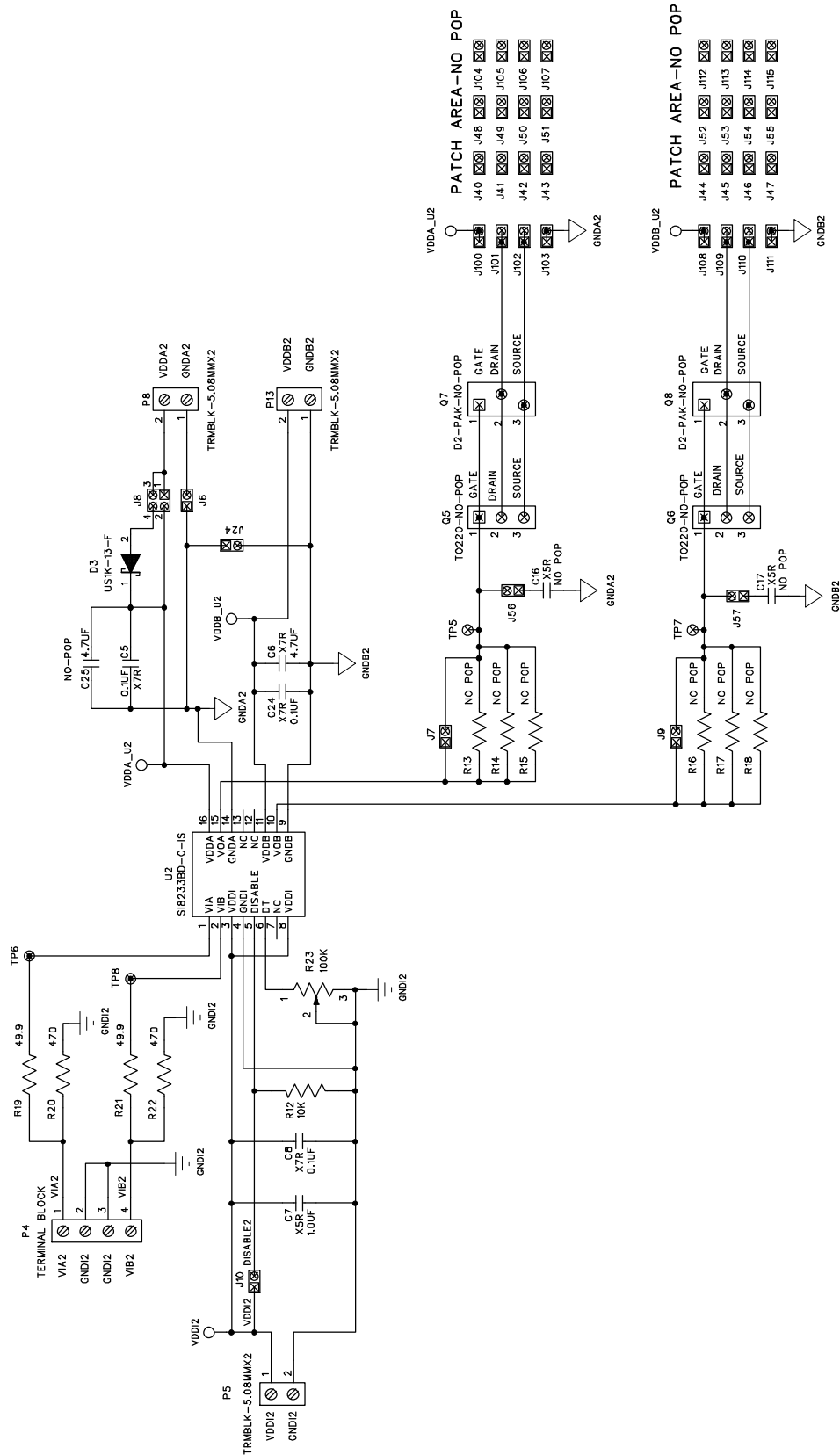

Figure 5. Si82xx Evaluation Board Schematic (2 of 4)



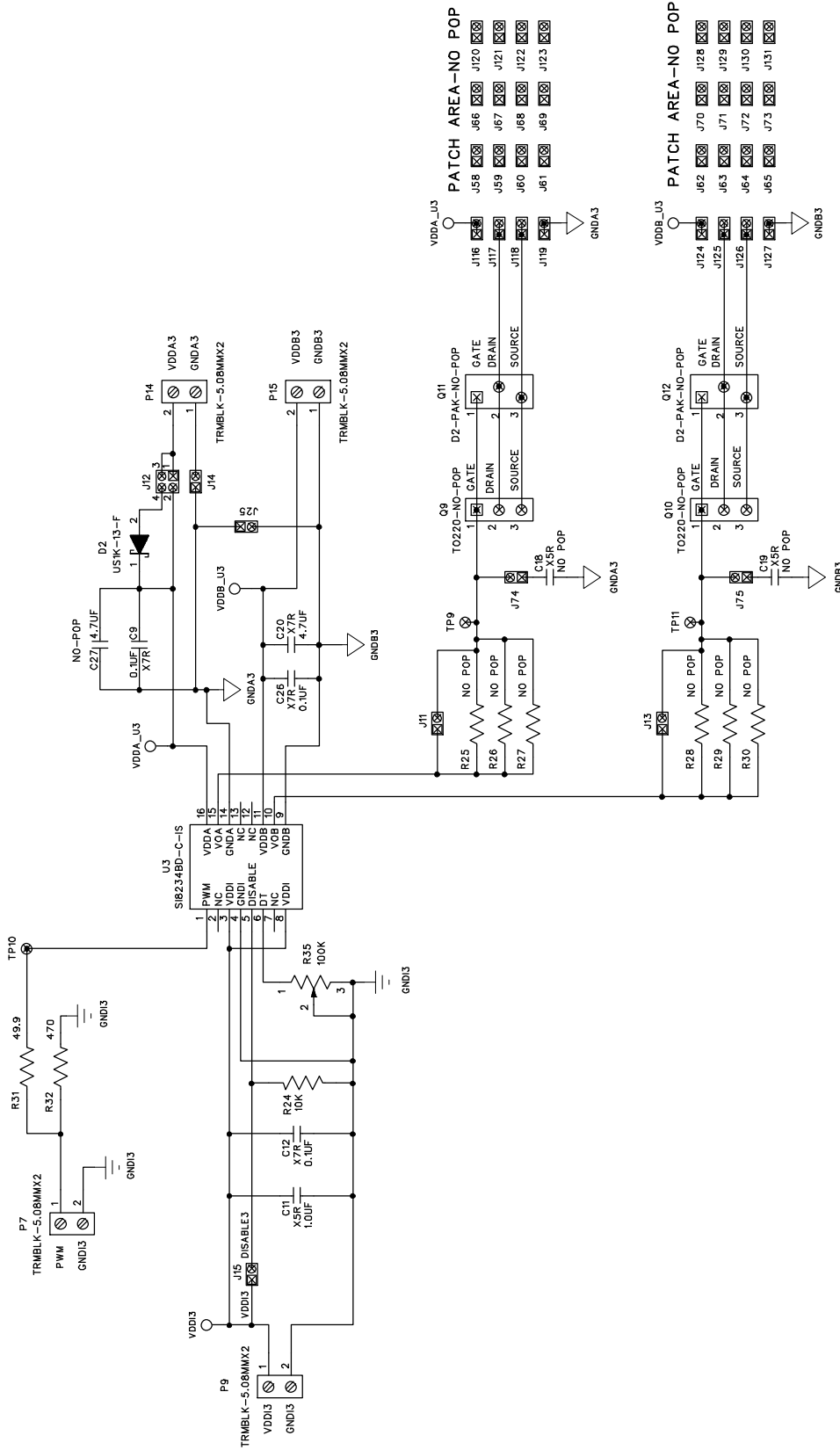

Figure 6. Si82xx Evaluation Board Schematic (3 of 4)

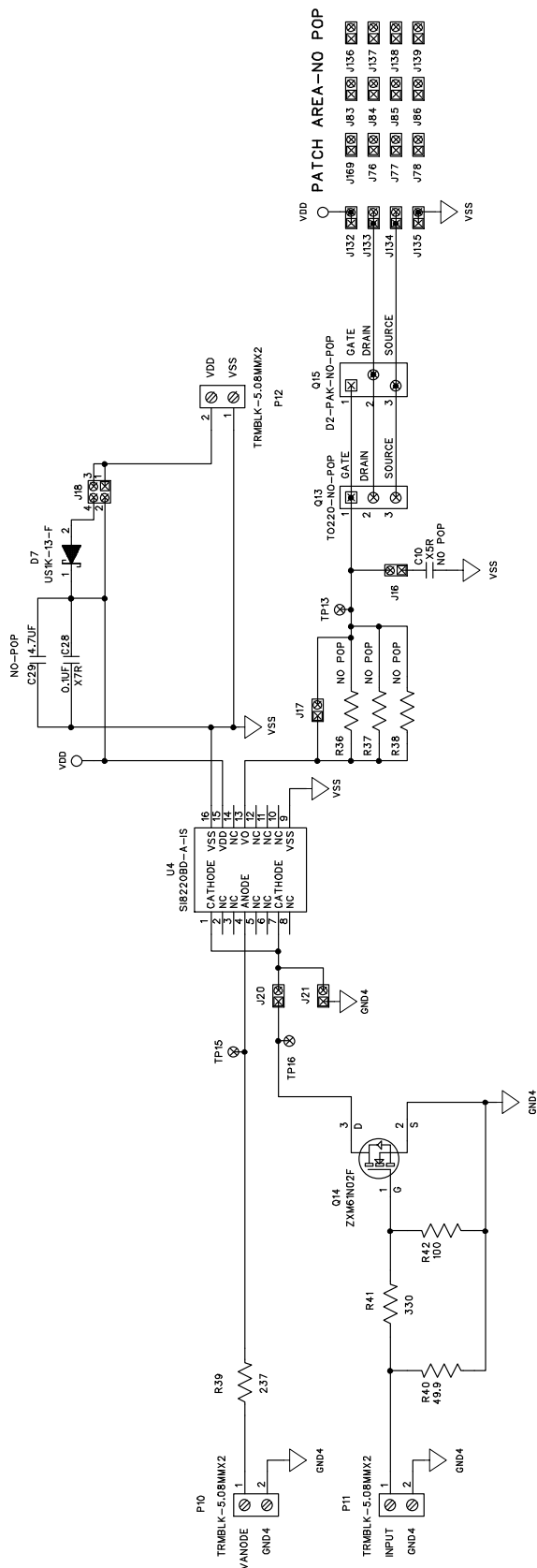

Figure 7. Si82xx Evaluation Board Schematic (4 of 4)

## 5. Si82xx Evaluation Board Layout

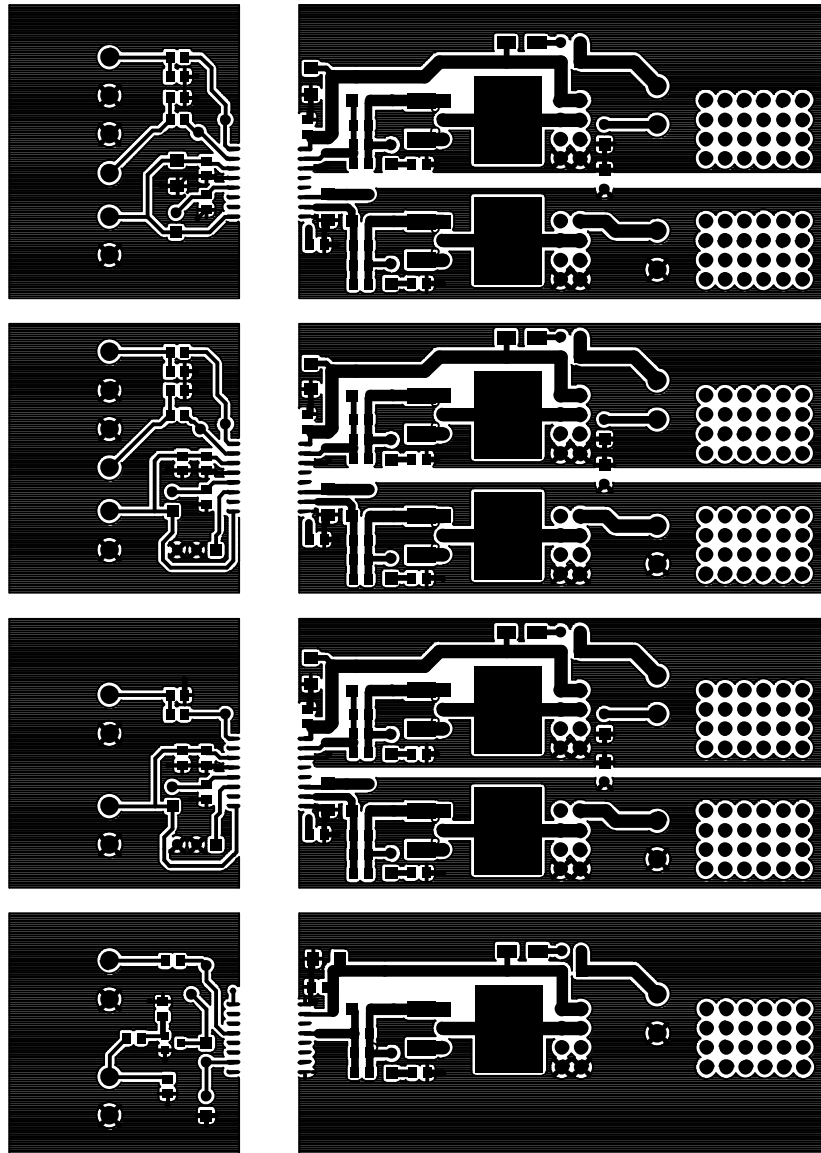

Figure 8. Si82xx Top Layer

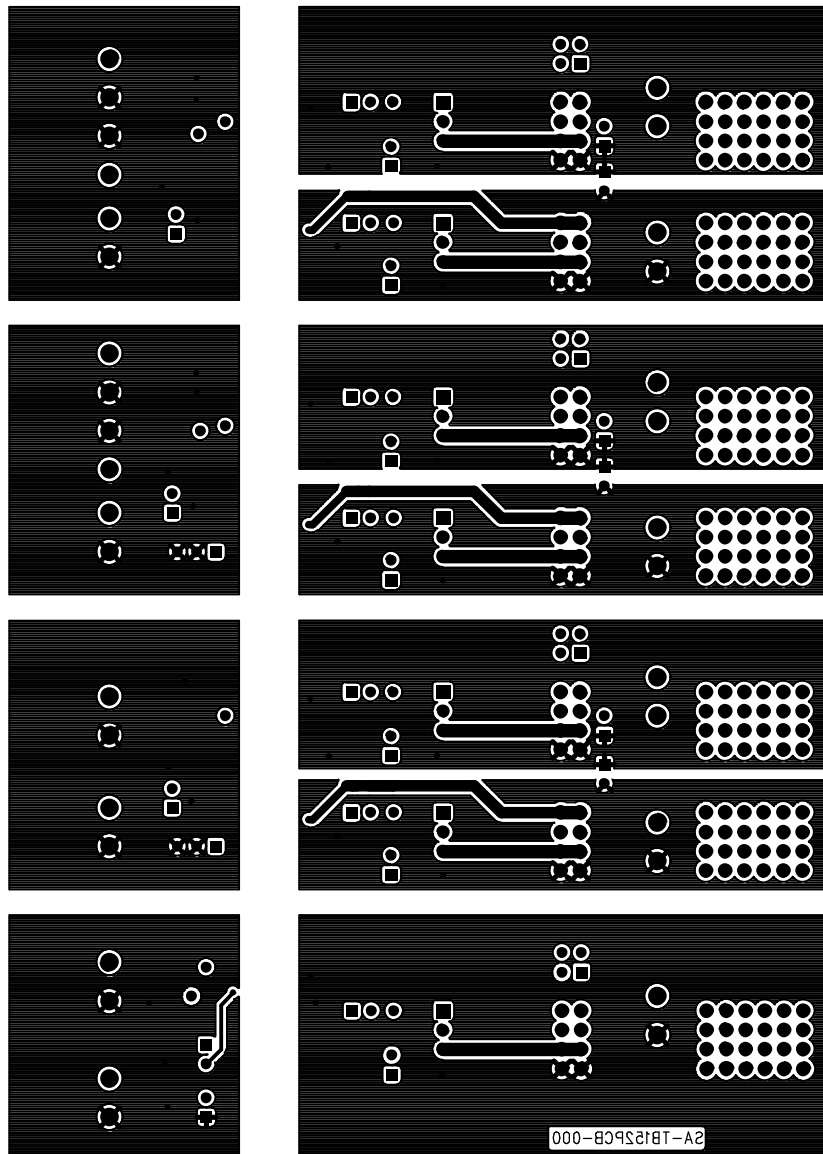

Figure 9. Si82xx Bottom Layer

# Si82xx-EVB UG

## 6. Bill of Materials

**Table 1. Si82xx-EVB Bill of Materials**

Item	Qty	Ref	Part Number	Mfr	Description
1	10	C1, C4–5, C8–9, C12, C22, C24, C26, C28	311-1140-2-ND	Digikey	Cap, 0.1 $\mu$ F, X7R, Ceramic, 50 V, 0805, $\pm$ 10%, or eq, RoHS
2	2	C7, C11	PCC2249CT-ND	Digikey	Cap 1.0 $\mu$ F, X5R, Ceramic, 0805, 16 V, $\pm$ 10%, or eq, RoHS
3	1	C3	PCC1893CT-ND	Digikey	Cap 1.0 $\mu$ F, X7R, Ceramic, 1206, 25 V, $\pm$ 10%, or eq, RoHS
4	3	C2, C6, C20	490-1809-1-ND	Digikey	Cap 4.7 $\mu$ F, X7R, Ceramic, 1206, 25 V, $\pm$ 10%, or eq, RoHS
5	4	C23, C25, C27, C29	490-1809-1-ND	Digikey	Cap 4.7 $\mu$ F, X7R, Ceramic, 1206, 25 V, $\pm$ 10%, or eq, RoHS, no-pop
6	7	C10, C14–19	CAP 0805	Digikey	Cap, NO POP, 0805, or eq, RoHS
7	7	Q3–4, Q7–8, Q11–12, Q15	D2-PAK-NO-POP	D2-pak-no-pop	D2-PAK-NO-POP or eq, RoHS
8	4	D1–3, D7	US1K-FDICT-ND	Digikey	Diode, SW ULT FAST, 1 A, 800 V, SMA, RoHS
9	25	J2–7, J9– 11, J13–17, J19–25, J56–57, J74–75	S1011E-02-ND	Digikey	Stake Header, 1X2, 0.1"CTR, Gold, or eq, RoHS
10	112	J26–55, J58–73, J76–78, J80–139, J168–169, J171	NO-POP	None	No-pop, RoHS
11	4	J1, J8, J12, J18	S2011E-02-ND	Digikey	Stake Header, 2X2, 0.1"CTR, Gold, OR Eq, RoHS
12	2	R23, R35	92W-104LF-ND	Digikey	Pot, 100 k $\Omega$ , Res, 3/8" SQ CERM SL, MT, TOP ADJ, $\pm$ 10%, OR EQ, RoHS
13	1	R42	P100ACT-ND	Digikey	Res, 100 $\Omega$ , SMT, 0805, 1/8W, $\pm$ 5%, OR EQ, RoHS



Table 1. Si82xx-EVB Bill of Materials (Continued)

Item	Qty	Ref	Part Number	Mfr	Description
14	3	R1, R12, R24	P10.0KCCT-ND	Digikey	Res, 10.0 k $\Omega$ , SMT, 0805, 1/8 W, $\pm$ 1%, or eq, RoHS
15	1	R39	311-237CRCT-ND	Digikey	Res 237 $\Omega$ , SMT, 0805, 1/8W, $\pm$ 1%, or eq, RoHS
16	1	R41	311-330ARCT-ND	Digikey	Res, 330 $\Omega$ , SMT, 0805, 1/8W, $\pm$ 5%, or eq, RoHS
17	5	R9, R11, R20, R22, R32	RHM470ACT-ND	Digikey	Res, 470 $\Omega$ , SMT, 0805, 1/8W, $\pm$ 5%, or eq, RoHS
18	6	R8, R10, R19, R21, R31, R40	P49.9CCT-ND	Digikey	Res, 49.9 $\Omega$ , SMT, 0805, 1/8W, $\pm$ 1%, or eq
19	21	R2–7, R13–18, R25–30, R36–38	NO POP	Digikey	Res, no pop, SMT, 0805, or eq, RoHS
20	1	U4	Si8220BD-A-IS	Silicon Labs	IC, 2.5 A, 5 kV, ISOdrivers with Opto Input, RoHS
21	1	U2	Si8233BD-C-IS	Silicon Labs	4.0 A, 5 kV, ISOdrivers, RoHS
22	1	U3	Si8234BD-C-IS	Silicon Labs	IC, 4.0 A, 5 kV, ISOdrivers, RoHS
23	1	U1	Si8235BD-C-IS	Silicon Labs	IC, 4.0 A, 5 kV, ISOdrivers, RoHS
24	4	RF1–4	SJ5744-0-ND	Digikey	Bumpon protective, bumper , Silicone, or eq, RoHS
25	14	TP1–11, TP13, TP15–16	No Pop	Digikey	Test point, PC compact, no pop, or eq, RoHS
26	7	Q1–2, Q5–6, Q9–10, Q13	TO220-NO-POP	To220-no-pop	TO220-no-pop, or eq, RoHS
27	13	P2–3, P5–15	277-1236-ND	Digikey	Conn Term Block, 5.08 mm ctrs, PCB, 2 POS, RoHS
28	2	P1, P4	277-1249-ND	Digikey	Conn Term Block, 5.08 mm ctrs, PCB, 4 POS, RoHS
29	1	Q14	ZXM61N02FCT-ND	Digikey	Mosfet, N-Chan, 20 V, 1.7 A, SOT23-3, RoHS

## 7. Ordering Guide

Table 2. Si82xx Evaluation Board Ordering Guide

Ordering Part Number (OPN)	Description
Si82xx-KIT	Si82xx CMOS ISOdriver evaluation board kit

**NOTES:**

# Si82xx-EVB UG

---

## CONTACT INFORMATION

Silicon Laboratories Inc.  
400 West Cesar Chavez  
Austin, TX 78701  
Tel: 1+(512) 416-8500  
Fax: 1+(512) 416-9669  
Toll Free: 1+(877) 444-3032

Please visit the Silicon Labs Technical Support web page:  
<https://www.silabs.com/support/pages/contacttechnicalsupport.aspx>  
and register to submit a technical support request.

The information in this document is believed to be accurate in all respects at the time of publication but is subject to change without notice. Silicon Laboratories assumes no responsibility for errors and omissions, and disclaims responsibility for any consequences resulting from the use of information included herein. Additionally, Silicon Laboratories assumes no responsibility for the functioning of undescribed features or parameters. Silicon Laboratories reserves the right to make changes without further notice. Silicon Laboratories makes no warranty, representation or guarantee regarding the suitability of its products for any particular purpose, nor does Silicon Laboratories assume any liability arising out of the application or use of any product or circuit, and specifically disclaims any and all liability, including without limitation consequential or incidental damages. Silicon Laboratories products are not designed, intended, or authorized for use in applications intended to support or sustain life, or for any other application in which the failure of the Silicon Laboratories product could create a situation where personal injury or death may occur. Should Buyer purchase or use Silicon Laboratories products for any such unintended or unauthorized application, Buyer shall indemnify and hold Silicon Laboratories harmless against all claims and damages.

Silicon Laboratories and Silicon Labs are trademarks of Silicon Laboratories Inc.

Other products or brandnames mentioned herein are trademarks or registered trademarks of their respective holders.