



Chipsmall Limited consists of a professional team with an average of over 10 year of expertise in the distribution of electronic components. Based in Hongkong, we have already established firm and mutual-benefit business relationships with customers from,Europe,America and south Asia,supplying obsolete and hard-to-find components to meet their specific needs.

With the principle of "Quality Parts,Customers Priority,Honest Operation,and Considerate Service",our business mainly focus on the distribution of electronic components. Line cards we deal with include Microchip,ALPS,ROHM,Xilinx,Pulse,ON,Everlight and Freescale. Main products comprise IC,Modules,Potentiometer,IC Socket,Relay,Connector.Our parts cover such applications as commercial,industrial, and automotives areas.

We are looking forward to setting up business relationship with you and hope to provide you with the best service and solution. Let us make a better world for our industry!



Contact us

Tel: +86-755-8981 8866 Fax: +86-755-8427 6832

Email & Skype: info@chipsmall.com Web: www.chipsmall.com

Address: A1208, Overseas Decoration Building, #122 Zhenhua RD., Futian, Shenzhen, China



Si84xxISO EVALUATION BOARD USER'S GUIDE

1. Introduction

The Si84xxISO evaluation board allows designers to evaluate Silicon Lab's family of CMOS ultra-low-power isolators. These isolators are CMOS devices employing RF coupler technology to transmit digital information across an isolation barrier. Very high speed operation at low power levels is achieved. These products are based on Silicon Laboratories' proprietary RF isolation technology and offer shorter propagation delays, lower power consumption, improved noise immunity, smaller installed size, and more stable operation with temperature and age versus opto couplers. The Si841x/2x/3x/4x/5x/6x include up to six unidirectional isolated channels, permitting data transmission up to 150 Mbps. The Si840x isolator series consists of single-package galvanic isolation solutions for I²C, SMBus, and PMBus serial port applications. For more information, refer to the respective family data sheets.

A summary of the benefits provided by the Silicon Laboratories Si84xx CMOS Digital Isolator family includes:

- Robust Noise Tolerance:
 - 5.0 kV, 2.5 kV, and 1.0 kV Isolation Ratings
 - Up to 50 V/m Electric-field immunity
 - > 1000 A/m Magnetic-field immunity
 - 25 kV/μs CMTI
 - FCC Class B Compliant
- Class-leading ESD Performance:
 - 4 kV HBM, 2 kV CDM, 400 V MM
- Ultra Low Power Operation:
 - < 1.4 mA/Channel @ 1 Mbps
 - 200 μA standby mode
- High Speed Operation:
 - DC–150 Mbps from –40 to 125 °C
 - < 250 ps (peak) Jitter
- Precise Timing:
 - 1.5 ns pulse width distortion
 - 0.5 ns channel-channel matching
 - 2 ns pulse width skew
- I²C Compatible Isolators:
 - Bidirectional isolated Serial Data (SDA) and Serial Clock
 - Data Rates up to 1.7 Mbps
 - 35 mA open drain I/O
- Flexible Packaging Options:
 - NB SOIC-8, WB SOIC-16, NB SOIC-16
 - RoHS compliant

Si84xxISO-EVB UG

2. Kit Contents

The Si84xxISO Evaluation Kit contains the following items:

- Si84xxISO based evaluation board (Si84xxISO-EVB or Si84xx5kVISO-EVB) shown in Figures 1 and 2.
- Si8400, Si8421, Si8442, Si8463, Si8420 (5 kV), and Si8422 (5 kV) CMOS digital isolators installed on the evaluation board

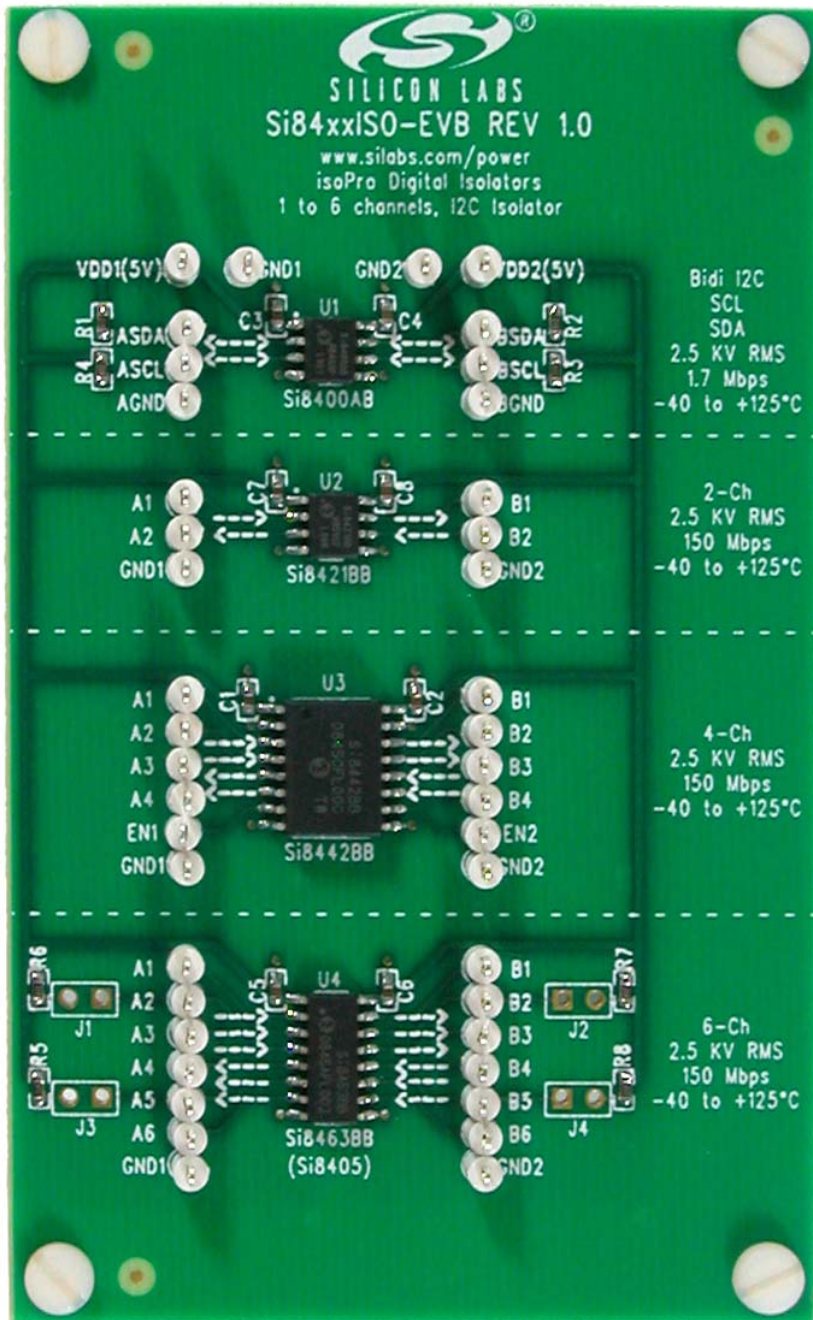

Figure 1. Si84xxISO Evaluation Board Overview

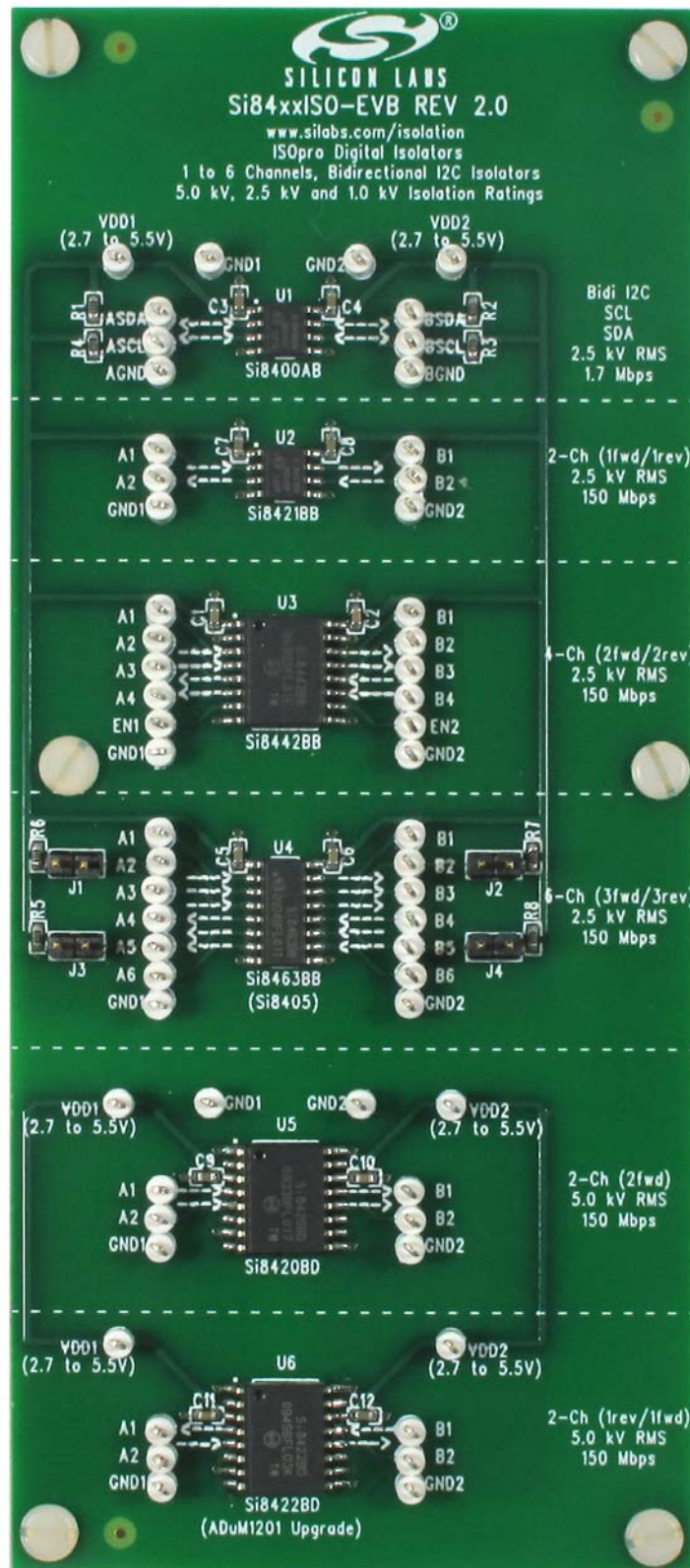

Figure 2. Si84xx5kVISO Evaluation Board Overview

Si84xxISO-EVB UG

3. Hardware Overview and Setup

The Si84xxISO evaluation board comes populated with an Si8400 (isolated I²C), Si8421 (2-channel digital isolator, one forward, one reverse), Si8442 (4-channel digital isolator, two forward, two reverse), and Si8463 (6-channel digital isolator, three forward, three reverse) installed. The Si84xx5kVISO-EVB adds the Si8420 and Si8422 5 kV family members. The board is designed to be powered from two separate 5 V supplies (500 mA) that power all the isolators on the board. Power is applied to the board before evaluating any isolated channel. Power is applied to the Si84xxISO-EVB by connecting 5 V supplies to the topmost supply terminals (VDD1 and GND1, VDD2 and GND2). Power is applied to the Si84xx5kVISO-EVB by applying 5 V supplies to the topmost and middle power terminals (VDD1 and GND1, VDD2 and GND2). The top power terminals power the 2.5 kV isolators. The middle power terminals power the 5 kV isolators. Supplies as low as 2.7 V can be used. If a user wants to evaluate an isolator other than the ones populated, this can be accomplished by removing the footprint-compatible device installed on the evaluation board and replacing it with the desired isolator device. Figures 3 and 5 provide silkscreen overviews of the boards.

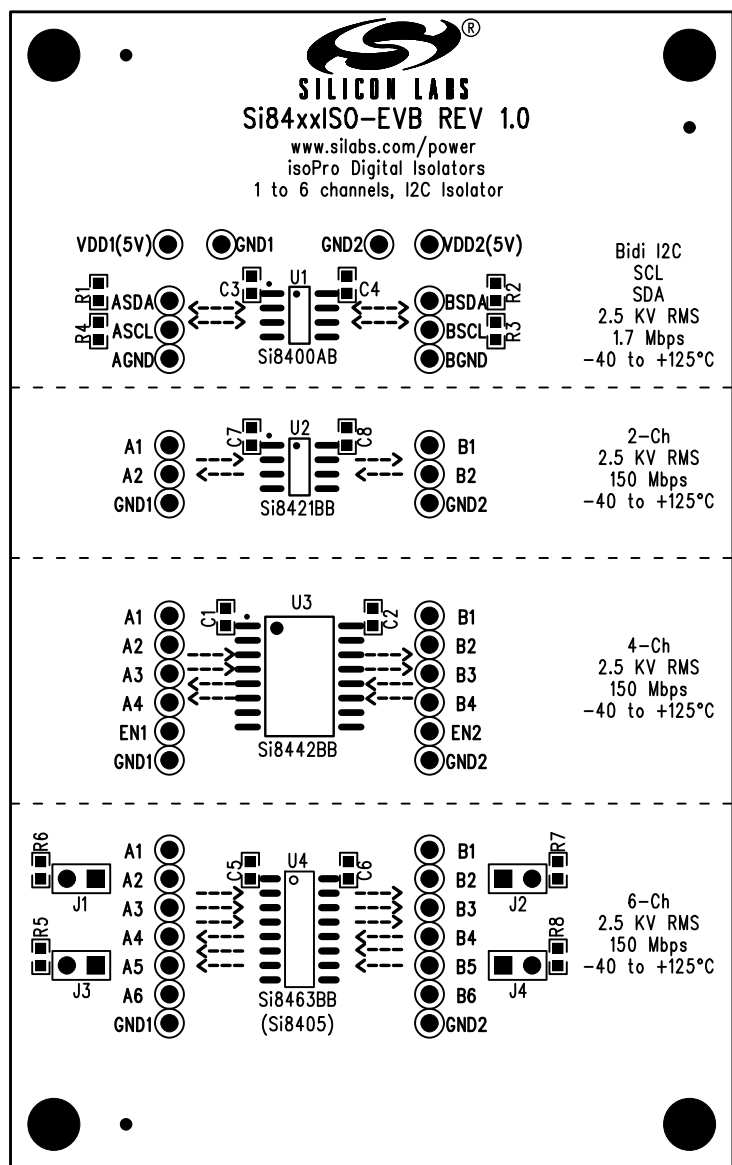

Figure 3. Si84xxISO Evaluation Board Silkscreen

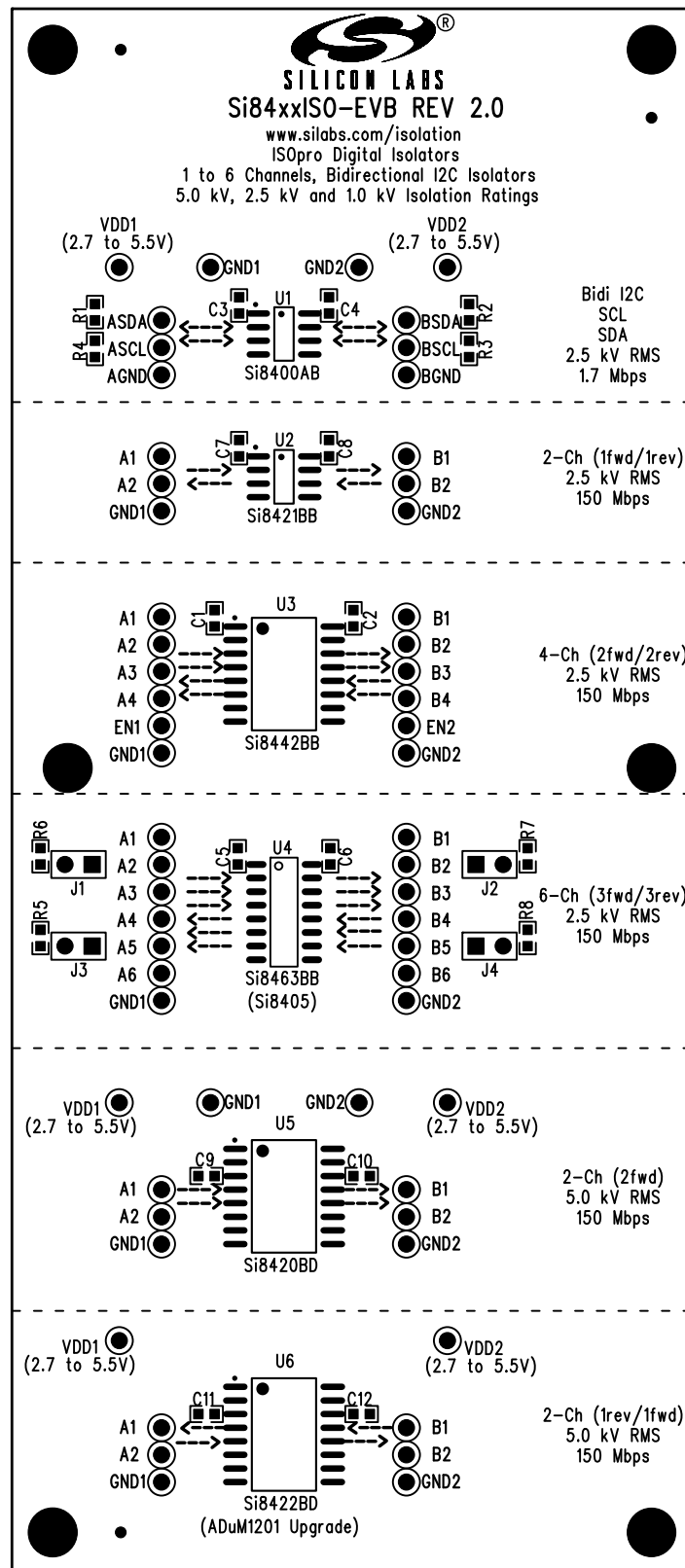

Figure 4. Si84xx5kVISO Evaluation Board Silkscreen

3.1. Digital Isolator Considerations

The Si84xxISO evaluation board (see Figure 1 on page 2) provides a means to evaluate the Si841x,2x,3x,4x,5x,6x digital isolator families as well as the Si8400 isolated I²C family. After power has been supplied to the board, connect a digital input signal (5 V_{peak} max, with desired clock frequency up to 150 Mbps) to the desired input channel. To view the isolated channel's data transmission, connect a scope probe to the output channel of interest. There are various inputs and outputs on either side of the board depending on the device one chooses to evaluate, as indicated by the silk screen. The board can be used to measure propagation delay, pulse-width distortion, channel-channel matching, pulse-width skew, and various other parameters.

The nominal output impedance of an isolator driver channel is approximately 50 Ω, ±40%, which is a combination of the values of the on-chip series termination resistor and the channel resistance of the output driver FET. When driving loads where transmission line effects will be a factor, output pins should be terminated with 50 Ω controlled impedance PCB traces.

Figure 5 illustrates the Si8421 transmitting a 500 kHz (5 V_{peak}) signal through the Si8421. VDD1 and VDD2 were powered from 5 V. Channel 1 illustrates the input, and Channel 2 illustrates the output.

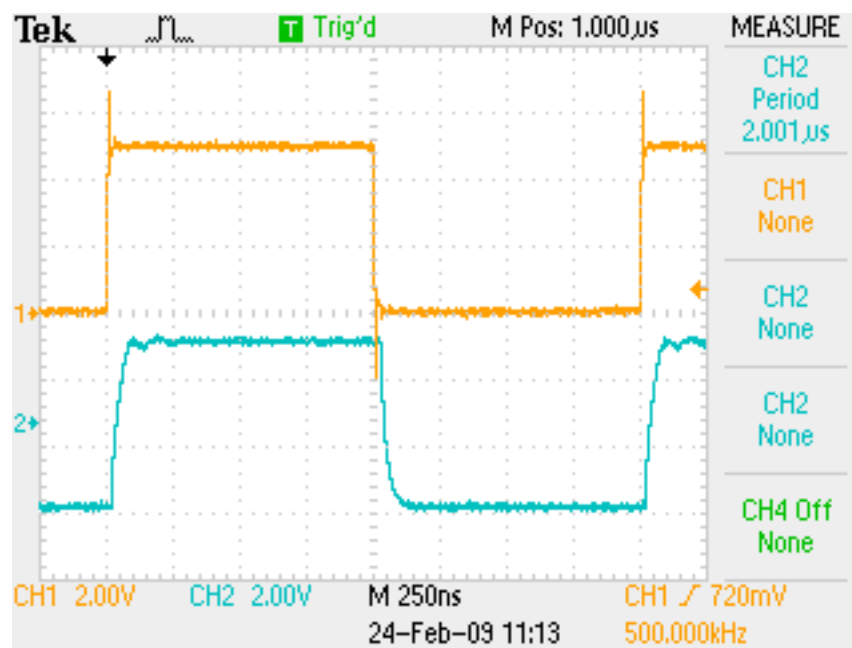

Figure 5. 500 kHz (5 V Peak) Signal

3.2. I²C Isolator Considerations

After power has been supplied to the board, connect a digital square wave input (5 V_{peak} max, with desired clock frequency up to 1.7 MHz) to the desired input channel. The Si8400 I²C isolator has 1 k Ω pull-up resistors already installed. If these resistors are redundant with another board that is being used to evaluate the Si8400, the user should remove the redundant pull-up resistors to accommodate adequate drive current for the test being performed. Moreover, note that the Si8463 can be replaced with an Si8405 (Bidirectional I²C Isolator with two unidirectional digital channels). Pull-up resistors of 1 k Ω are already installed to accommodate the Si8405's evaluation. Pull-up jumpers J1, J2, J3, and J4 need to be installed to evaluate the Si8405. They will need to be removed or not installed (default from factory) to evaluate the Si8463.

Figure 6 illustrates Side B Pulling Up, with Side A following for the Si8400. The Si8400 was powered from 5 V on both sides with a 100 kHz input test signal.

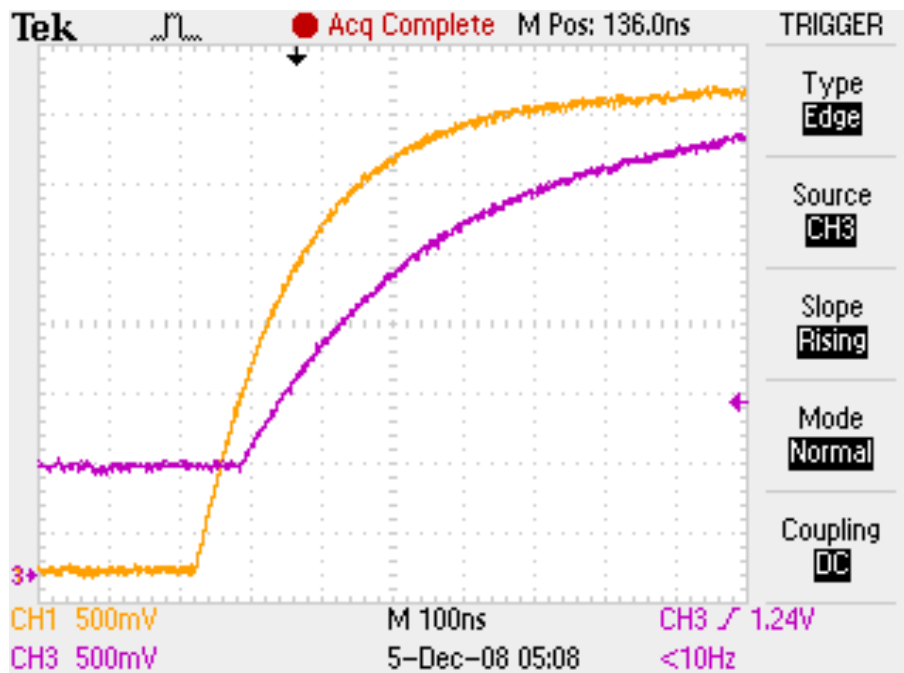

Figure 6. Side B Pulling Up, Side A Following

Note: The test points in front of each device have 1 mm spacing. If desired, the test points can be replaced with a 1 mm spacing terminal block to assist in evaluation.

4. Si84xxISO Evaluation Board Schematic

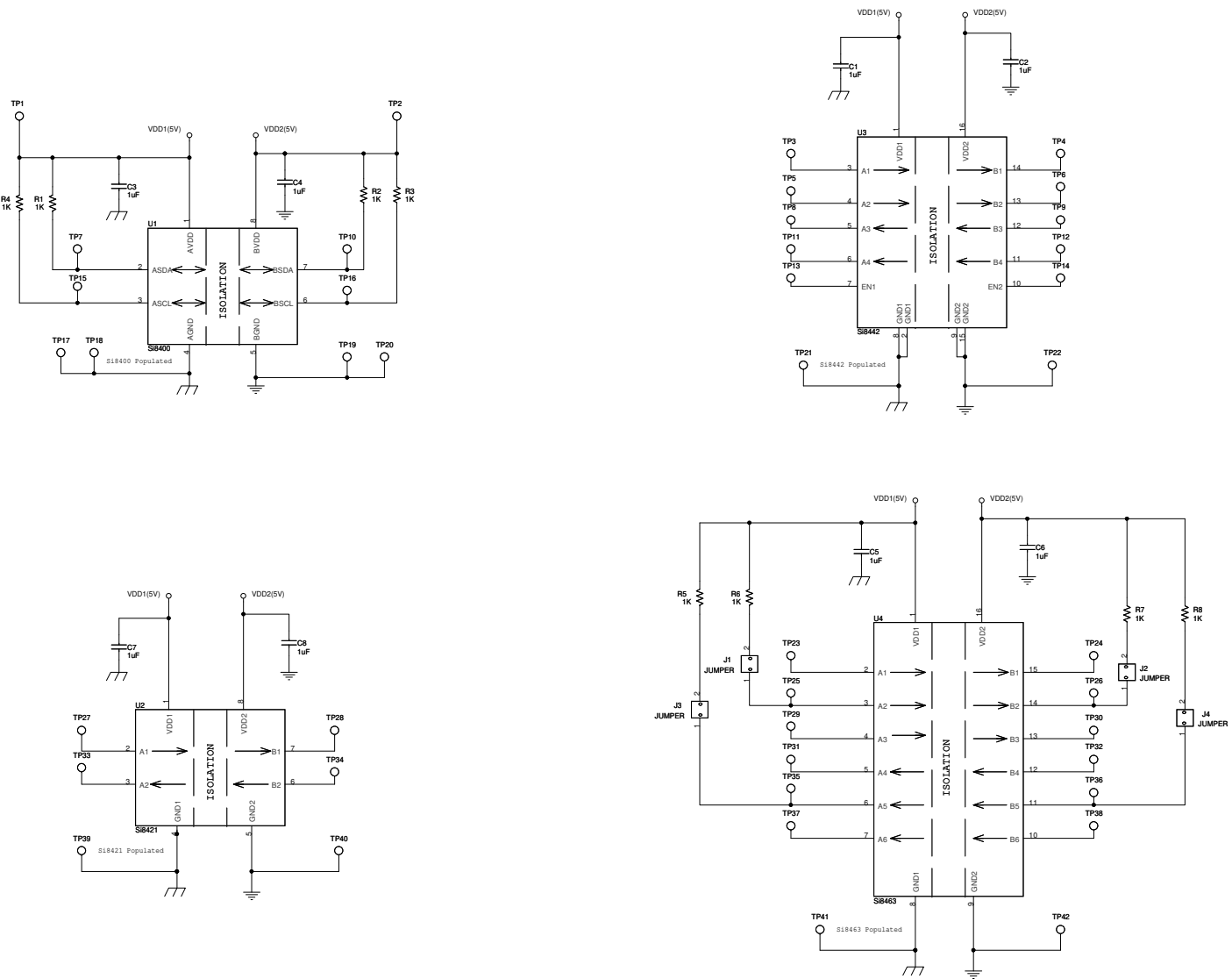

Figure 7. Si84xxISO Evaluation Board Schematic

5. Si84xx5kVISO Evaluation Board Schematics

Si84xxISO-EVB UG

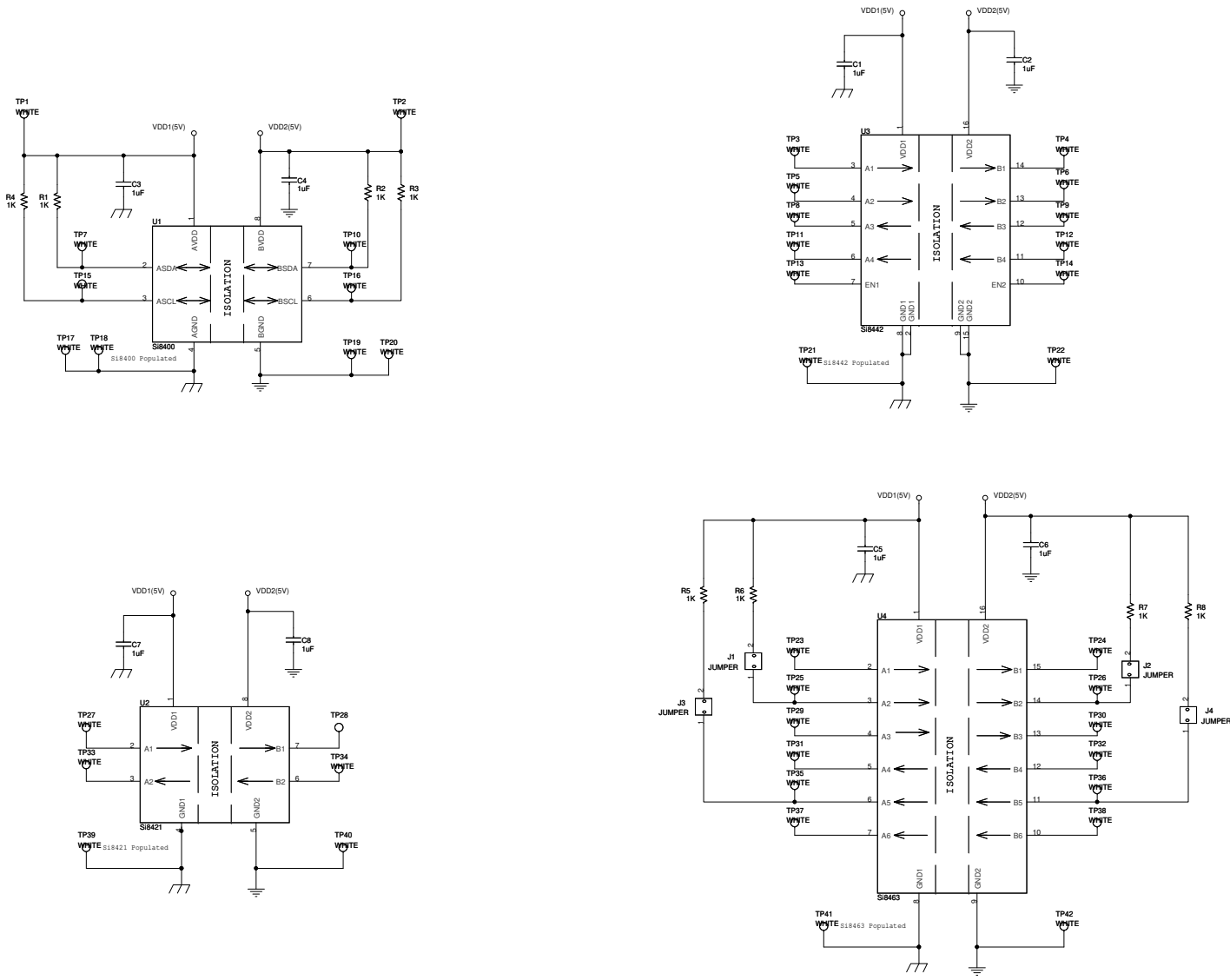

Figure 8. Si84xx5kVISO Evaluation Board Schematic (1 of 2)

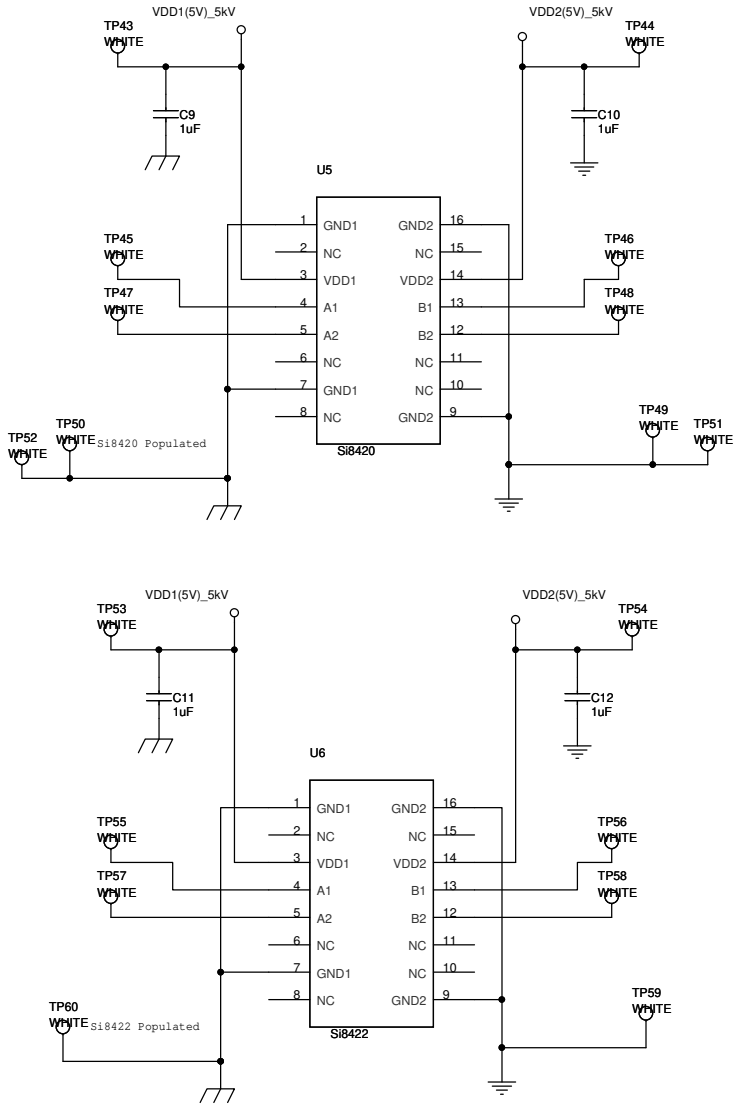

Figure 9. Si84xx5kVISO Evaluation Board Schematic (2 of 2)

6. Bill of Materials

Table 1. Si84xxISO Evaluation Board Bill of Materials

Item	Qty	Reference	Value	Mfr Part Number	Mfr
1	8	C1,C2,C3,C4, C5,C6,C7,C8	1 μ F	C0603X5R250-105K	Venkel
2	4	J1,J2,J3,J4	Jumper	TSW-102-07-T-S	Samtec
3	8	R1,R2,R3,R4, R5,R6,R7,R8	1 k Ω	CR0603-10W-1001F	Venkel
4	42	TP1,TP2,TP3,TP4, TP5,TP6,TP7,TP8, TP9,TP10,TP11, TP12,TP13,TP14, TP15,TP16,TP17, TP18,TP19,TP20, TP21,TP22,TP23, TP24,TP25,TP26, TP27,TP28,TP29, TP30,TP31,TP32, TP33,TP34,TP35, TP36,TP37,TP38, TP39,TP40,TP41, TP42	White	151-201-RC	Kobiconn
5	1	U1	Si8400	Si8400AB-A-IS	Silicon Labs
6	1	U2	Si8421	Si8421AB-C-IS1	Silicon Labs
7	1	U3	Si8442	Si8442BB-C-IS	Silicon Labs
8	1	U4	Si8463	Si8463BB-A-IS1	Silicon Labs

Si84xxISO-EVB UG

Table 2. Si84xx5kVISO Evaluation Board Bill of Materials

Item	Qty	Reference	Value	Mfr Part Number	Mfr
1	12	C1,C2,C3,C4,C5,C6,C7, C8,C9,C10,C11,C12	1uF	C0603X5R250-105K	Venkel
2	4	J1,J2,J3,J4	JUMPER	TSW-102-07-T-S	Samtec
3	8	R1,R2,R3,R4,R5,R6,R7,R8	1 kΩ	CR0603-10W-1001F	Venkel
4	60	TP1,TP2,TP3,TP4,TP5, TP6,TP7,TP8,TP9,TP10, TP11,TP12,TP13,TP14, TP15,TP16,TP17,TP18, TP19,TP20,TP21,TP22, TP23,TP24,TP25,TP26, TP27,TP28,TP29,TP30, TP31,TP32,TP33,TP34, TP35,TP36,TP37,TP38, TP39,TP40,TP41,TP42, TP43,TP44,TP45,TP46, TP47,TP48,TP49,TP50, TP51,TP52,TP53,TP54, TP55,TP56,TP57,TP58, TP59,TP60	WHITE	151-201-RC	Kobiconn
5	1	U1	Si8400	Si8400AB-A-IS	Silicon Labs
6	1	U2	Si8421	Si8421AB-C-IS1	Silicon Labs
7	1	U3	Si8442	Si8442BB-C-IS	Silicon Labs
8	1	U4	Si8463	Si8463BB-A-IS1	Silicon Labs
9	1	U5	Si8420	Si8420BD-A-IS	Silicon Labs
10	1	U6	Si8422	Si8422BD-B-IS	Silicon Labs
11	6		Standoff		
12	6		Standoff screw		

7. Ordering Guide

Table 3. Si84xxISO Evaluation Board Ordering Guide

Ordering Part Number (OPN)	Description
Si84XXISO-KIT	Si84xx CMOS digital isolator evaluation board kit (2.5 kV, 5 kV)

DOCUMENT CHANGE LIST

Revision 0.1 to Revision 0.2

- Added Si84xx5kVISO-EVB descriptive details throughout.
 - Added Figure 2 on page 3.
 - Added Figure 4 on page 5.
 - Added Figure 8 on page 9.
 - Added Figure 9 on page 10.
 - Added Table 2.

Revision 0.2 to Revision 0.3

- Replaced “ISOpro” with “CMOS” in text.
- Added "7. Ordering Guide" on page 13.

NOTES:

CONTACT INFORMATION

Silicon Laboratories Inc.
400 West Cesar Chavez
Austin, TX 78701
Tel: 1+(512) 416-8500
Fax: 1+(512) 416-9669
Toll Free: 1+(877) 444-3032

Please visit the Silicon Labs Technical Support web page:
<https://www.silabs.com/support/pages/contacttechnicalsupport.aspx>
and register to submit a technical support request.

The information in this document is believed to be accurate in all respects at the time of publication but is subject to change without notice. Silicon Laboratories assumes no responsibility for errors and omissions, and disclaims responsibility for any consequences resulting from the use of information included herein. Additionally, Silicon Laboratories assumes no responsibility for the functioning of undescribed features or parameters. Silicon Laboratories reserves the right to make changes without further notice. Silicon Laboratories makes no warranty, representation or guarantee regarding the suitability of its products for any particular purpose, nor does Silicon Laboratories assume any liability arising out of the application or use of any product or circuit, and specifically disclaims any and all liability, including without limitation consequential or incidental damages. Silicon Laboratories products are not designed, intended, or authorized for use in applications intended to support or sustain life, or for any other application in which the failure of the Silicon Laboratories product could create a situation where personal injury or death may occur. Should Buyer purchase or use Silicon Laboratories products for any such unintended or unauthorized application, Buyer shall indemnify and hold Silicon Laboratories harmless against all claims and damages.

Silicon Laboratories and Silicon Labs are trademarks of Silicon Laboratories Inc.

Other products or brandnames mentioned herein are trademarks or registered trademarks of their respective holders.