



Chipsmall Limited consists of a professional team with an average of over 10 year of expertise in the distribution of electronic components. Based in Hongkong, we have already established firm and mutual-benefit business relationships with customers from,Europe,America and south Asia,supplying obsolete and hard-to-find components to meet their specific needs.

With the principle of "Quality Parts,Customers Priority,Honest Operation,and Considerate Service",our business mainly focus on the distribution of electronic components. Line cards we deal with include Microchip,ALPS,ROHM,Xilinx,Pulse,ON,Everlight and Freescale. Main products comprise IC,Modules,Potentiometer,IC Socket,Relay,Connector.Our parts cover such applications as commercial,industrial, and automotives areas.

We are looking forward to setting up business relationship with you and hope to provide you with the best service and solution. Let us make a better world for our industry!



Contact us

Tel: +86-755-8981 8866 Fax: +86-755-8427 6832

Email & Skype: info@chipsmall.com Web: www.chipsmall.com

Address: A1208, Overseas Decoration Building, #122 Zhenhua RD., Futian, Shenzhen, China



**Silicon Image**

PanelLink[®]
Technology

Sil 1160
PanelLink Transmitter
Data Sheet

Document # Sil-DS-0126-B

Silicon Image, Inc.

SI-DS-0126-B
March 2005

Application Information

To obtain the most updated Application Notes and other useful information for your design, please visit the Silicon Image web site at www.siliconimage.com or contact your local Silicon Image sales office.

Copyright Notice

This manual is copyrighted by Silicon Image, Inc. Do not reproduce, transform to any other format, or send/transmit any part of this documentation without the expressed written permission of Silicon Image, Inc.

Trademark Acknowledgment

Silicon Image, the Silicon Image logo, PanelLink[®] and the PanelLink[®] Digital logo are registered trademarks of Silicon Image, Inc. TMDS[™] is a trademark of Silicon Image, Inc. I²C is a trademark of Philips Semiconductor. All other trademarks are the property of their respective holders.

Disclaimer

This document provides technical information for the user. Silicon Image, Inc. reserves the right to modify the information in this document as necessary. The customer should make sure that they have the most recent data sheet version. Silicon Image, Inc. holds no responsibility for any errors that may appear in this document. Customers should take appropriate action to ensure their use of the products does not infringe upon any patents. Silicon Image, Inc. respects valid patent rights of third parties and does not infringe upon or assist others to infringe upon such rights.

All information contained herein is subject to change without notice.

Revision History

Revision	Date	Comment
A	07/07/04	Data Sheet – 1 st release
B	03/01/05	Data Sheet – 2 nd release – added I ² C registers and pins, added dual zone PLL information, corrected recommended R _{EXT_SWING} value from 380Ω to 510Ω, corrected package JEDEC code, added reset description.

© 2005 Silicon Image, Inc.

TABLE OF CONTENTS

General Description	1
Features	1
Functional Description	3
Electrical Specifications	4
Absolute Maximum Conditions	4
Normal Operating Conditions	4
Digital I/O Specifications	4
DC Specifications	5
AC Specifications	5
Input Timing Diagrams	6
Pin Descriptions	8
Input Pins	8
Control and Configuration Pins	8
Power Management Pins	9
Differential Signal Data Pins	9
Local Control (I ² C) Interface	9
Reserved Pins	10
Power and Ground Pins	10
Feature Information	11
I ² C Interface	11
I ² C Register Mapping	12
Dual Zone PLL	13
Manual Zone Control	13
Automatic Zone Control	14
Reset Description	14
TFT Panel Data Mapping	15
Design Recommendations	20
Differences Between SiI 160 and SiI 1160	20
EXT_SWING Selection	20
PCB Ground Planes	20
Voltage Ripple Regulation	20
Spread Spectrum Support	21
Reset Circuit for I ² C Application	22
Power Control	22
Decoupling Capacitors	23
Series Damping Resistors on Outputs	24
Source Termination Resistors on Differential Outputs	24
Differential Trace Routing	25
Package Dimensions	28
Package	28
Ordering Information	28

LIST OF TABLES

Table 1. General I ² C Register Bits.....	13
Table 2. Dual Zone PLL I ² C Control Register Bits.....	14
Table 3. One Pixel/Clock Input/Output TFT Mode.....	15
Table 4. Two Pixels/Clock Input/Output TFT Mode.....	16
Table 5. 24-bit One Pixel/Clock Input with 24-bit Two Pixels/Clock Output TFT Mode.....	17
Table 6. 18-bit One Pixel/Clock Input with 18-bit Two Pixels/Clock Output TFT Mode.....	18
Table 7. Two Pixels/Clock Input with One Pixel/Clock Output TFT Mode.....	19
Table 8. New Pin Functions for SiI 1160 Tx.....	20
Table 9. Power Consumption Characteristics.....	22
Table 10. Recommended Components for Bypass and Decoupling Circuits.....	23
Table 11. Routing Guidelines for DVI Traces.....	27

LIST OF FIGURES

Figure 1. System Block Diagram – Typical Application.....	1
Figure 2. Pin Diagram for SiI 1160.....	2
Figure 3. Functional Block Diagram.....	3
Figure 4. Clock Cycle High/Low Times.....	6
Figure 5. Input Data Setup/Hold Time to IDCK.....	6
Figure 6. VSYNC, HSYNC and CTL[3:1] Delay Time from DE.....	6
Figure 7. DE High and Low Times.....	6
Figure 8. Reset Timing at Power-Up or Prior to First I ² C Access.....	7
Figure 9. I ² C Byte Read.....	11
Figure 10. I ² C Byte Write.....	11
Figure 11. Voltage Regulation using LM317EMP.....	20
Figure 12. Planned Spread Spectrum Support Circuit.....	21
Figure 13. Typical Reset Circuit.....	22
Figure 14. Decoupling and Bypass Capacitor Placement.....	23
Figure 15. Decoupling and Bypass Schematic.....	23
Figure 16. Series Input Damping Resistors for Driving Source.....	24
Figure 17. Differential Output Source Terminations.....	24
Figure 18. Source Termination Layout Illustration.....	25
Figure 19. Example of Incorrect Differential Signal Routing.....	26
Figure 20. Example of Correct Differential Signal Routing.....	26
Figure 21. Differential Trace Routing to DVI Connector (Top Side View).....	26
Figure 22. 100-pin TQFP Package Dimensions (JEDEC code MS-026-AED).....	28

General Description

The Sil 1160 transmitter uses Panellink Digital technology to support displays up to UXGA resolution. It supports up to true-color panels (24 bits per pixel, 16.7M colors) in 1 or 2 pixels-per-clock mode.

All Panellink products are designed on scaleable CMOS architecture to support future performance requirements while maintaining the same logical interface. The Sil 1160 transmitter follows this strategy by offering a pin-compatible upgrade to the Sil 160 transmitter that also brings longer cable support.

Panellink Digital technology simplifies the PC & display interface by resolving many of the system level issues associated with high-speed digital design, providing the system designer with a digital solution that is quicker to market and lower in cost.

Features

- Scaleable Bandwidth: 25-165 MHz (VGA to UXGA)
- Backwards compatible replacement for the Sil 160 transmitter
- High Skew Inter pair Tolerance: 1 full input clock cycle (6ns at 165 MHz)
- Flexible interface: single or dual pixel input at up to 48 bits
- Cable Distance Support: over 20m DVI cable
- Fully DVI 1.0 compliant
- Advanced on-chip input clock jitter filter to ensure clean output to receiver
- Available in Universal package for both standard and Pb-Free (environmentally-friendly) applications.

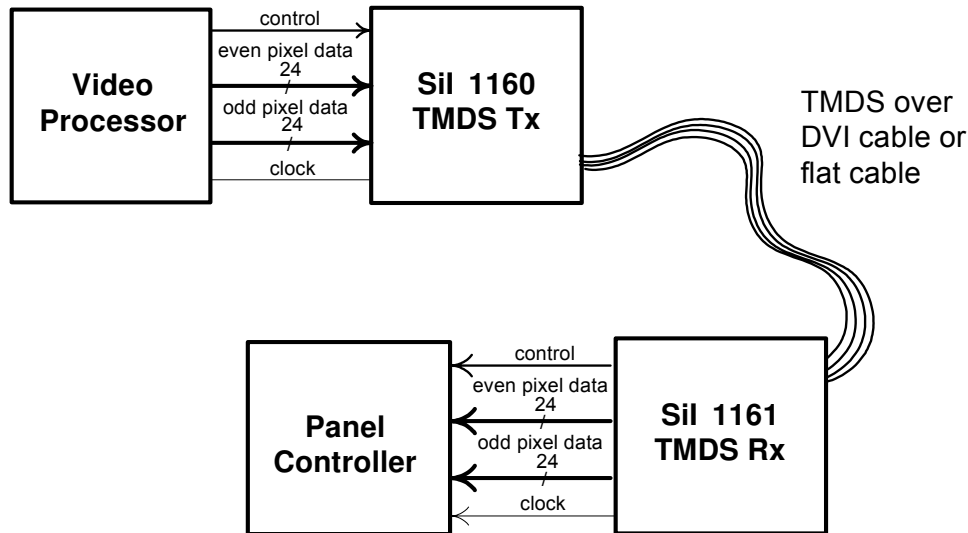

Figure 1. System Block Diagram – Typical Application

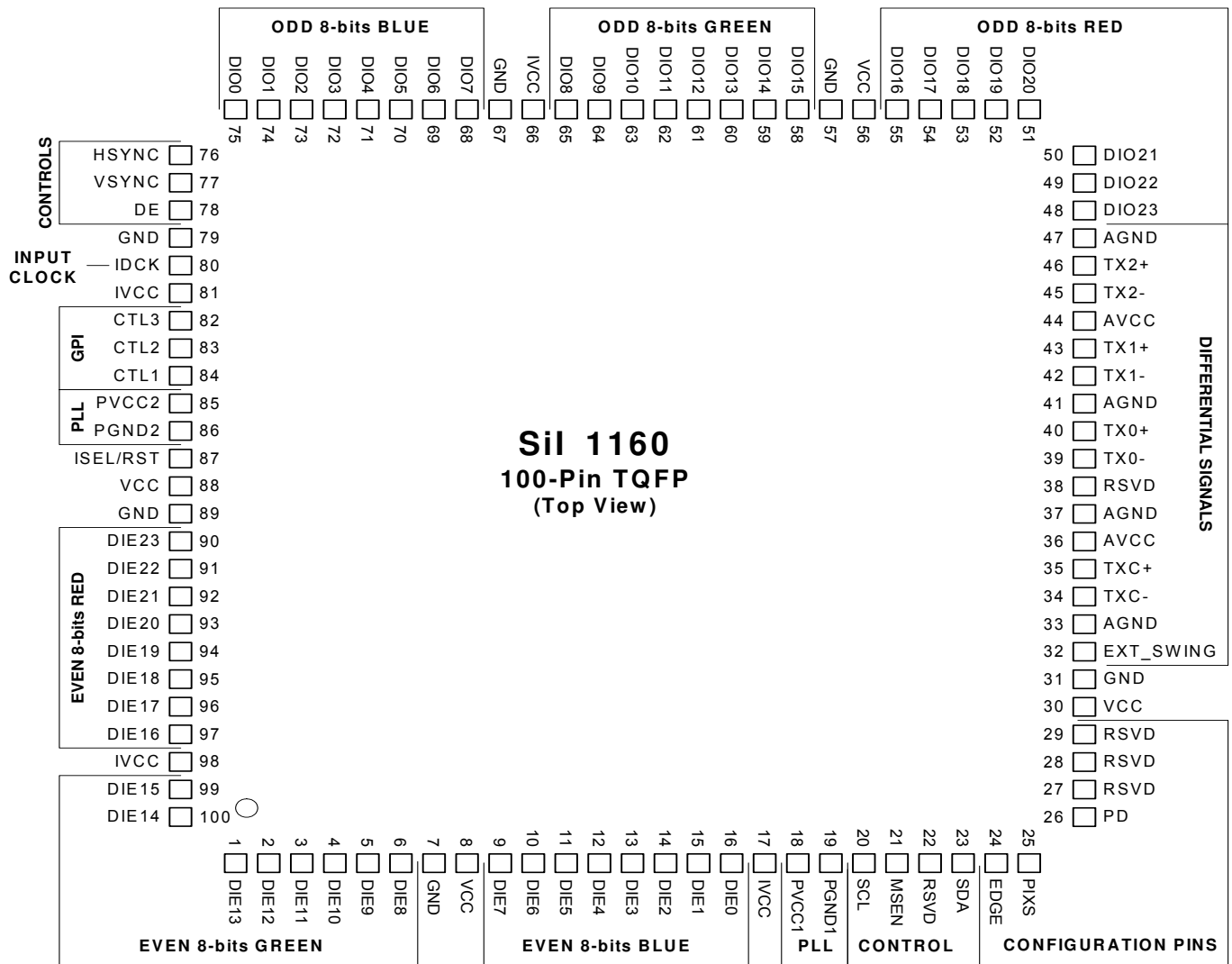

Figure 2. Pin Diagram for SiI 1160

Functional Description

The SiI 1160 Tx is a DVI 1.0 compliant PanelLink transmitter in a compact package. It provides 48 bits for data input to allow for panel support up to UXGA. Figure 3 shows the functional blocks of the chip.

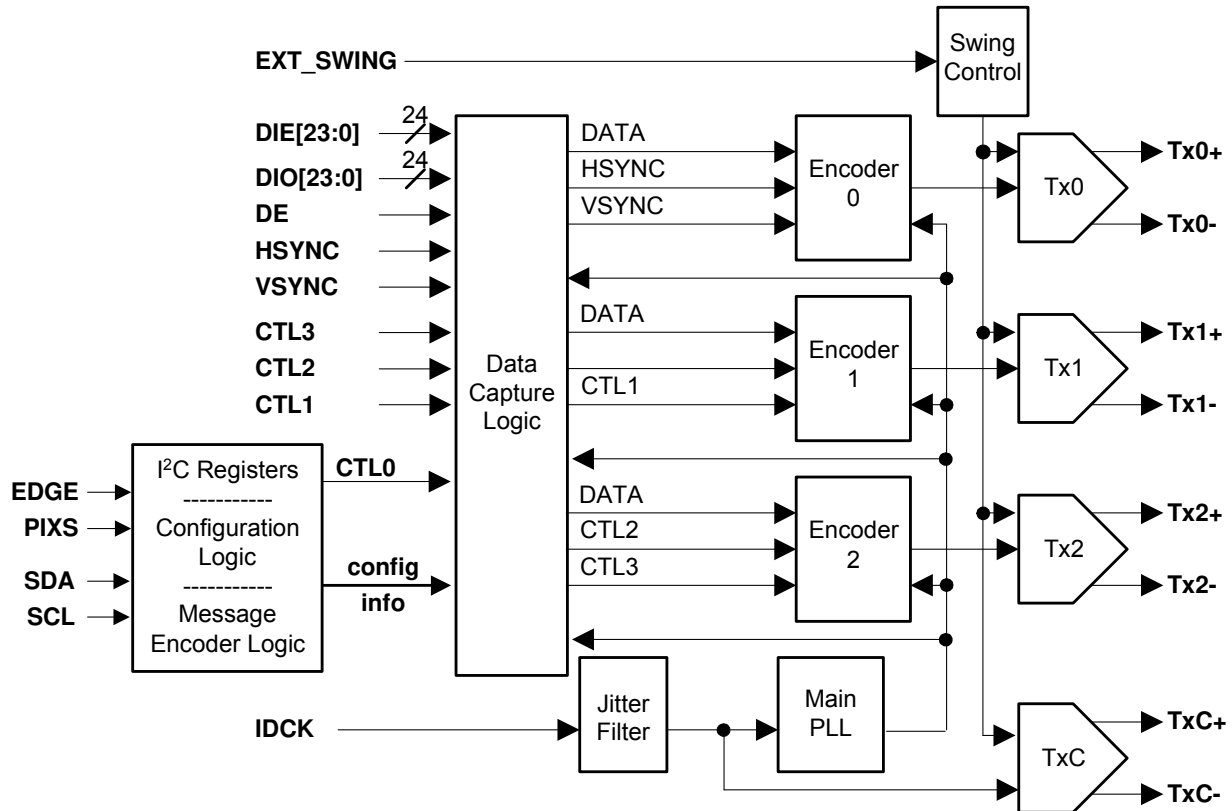

Figure 3. Functional Block Diagram

Electrical Specifications

Absolute Maximum Conditions

Symbol	Parameter	Min	Typ	Max	Units
V_{CC}^1	Supply Voltage 3.3V	-0.3		4.0	V
V_I	Input Voltage	-0.3		$V_{CC} + 0.3$	V
V_O^2	Input Voltage	-0.3		$V_{CC} + 0.3$	V
T_j	Junction Temperature (with power applied)			125	°C
T_{STG}	Storage Temperature	-65		150	°C

Note

1. Permanent device damage may occur if absolute maximum conditions are exceeded.
2. Functional operation should be restricted to the conditions described under normal operating conditions.

Normal Operating Conditions

Symbol	Parameter	Min	Typ	Max	Units
V_{CC}	Supply Voltage	3.0	3.3	3.6	V
V_{CCN}	Supply Voltage Noise			100	mV _{P-P}
T_A	Ambient Temperature (with power applied)	0	25	70	°C
θ_{JA}	Thermal Resistance (junction to ambient) ¹			53	°C/W

Note

1. Airflow at 0m/s.

Digital I/O Specifications

Under normal operating conditions unless otherwise specified.

Symbol	Parameter	Conditions	Min	Typ	Max	Units
V_{IH}	High-level Input Voltage		2			V
V_{IL}	Low-level Input Voltage				0.8	V
V_{OH}	High-level Input Voltage		2.4			V
V_{OL}	Low-level Input Voltage				0.4	V
V_{CINL}	Input Clamp Voltage ¹	$I_{CL} = -18mA$			GND -0.8	V
V_{CIPL}	Input Clamp Voltage ¹	$I_{CL} = 18mA$			IVCC + 0.8	V
V_{CONL}	Input Clamp Voltage ¹	$I_{CL} = -18mA$			GND -0.8	V
V_{COPL}	Input Clamp Voltage ¹	$I_{CL} = 18mA$			OVCC + 0.8	V
I_{OL}	Input Leakage Current	High Impedance	-10		10	μA

Note

1. Guaranteed by design. Voltage undershoot or overshoot cannot exceed absolute maximum conditions for a pulse of greater than 3 ns or one third of the clock cycle.

DC Specifications

Under normal operating conditions, with $R_{EXT_SWING} = 510\Omega$ and using source termination, unless otherwise specified.

Symbol	Parameter	Conditions	Min	Typ	Max	Units
V_{OD}	Differential Voltage Single ended peak to peak amplitude	$R_{LOAD} = 50\Omega$	510	550	590	mV
V_{DOH}	Differential High-level Output Voltage ¹			AVCC		V
I_{DOS}	Differential Output Short Circuit Current ¹	$V_{OUT} = 0\text{ V}$			5	μA
I_{PD}	Power-down Current ²				5	mA
I_{CCT}	Transmitter Supply Current	IDCK= 165 MHz, two pixel per clock mode IVCC = VCC, Worst Case Pattern ³		140	200	mA

Notes

1. Guaranteed by design.
2. Assumes all inputs to the transmitter are not toggling.
3. The Worst Case Pattern consists of a black and white checkerboard pattern, each checker one pixel wide.

AC Specifications

Under normal operating conditions with source termination and the recommended R_{EXT_SWING} value unless otherwise specified.

Symbol	Parameter	Conditions	Min	Max	Units
T_{CIP}	IDCK Period, 1 Pixel/Clock		6	40	ns
F_{CIP}	IDCK Frequency, 1 Pixel/Clock		25	165	MHz
T_{CIP}	IDCK Period, 2 Pixels/Clock		12	80	ns
F_{CIP}	IDCK Frequency, 2 Pixels/Clock		12	81	MHz
T_{CIH}	IDCK High Time at 165MHz		2		ns
T_{CIL}	IDCK Low Time at 165MHz		2		ns
T_{SIDF}	Data, DE, VSYNC, HSYNC, and CTL[3:1] Setup Time to IDCK falling edge	EDGE = 0	1.5		ns
T_{HIDF}	Data, DE, VSYNC, HSYNC, and CTL[3:1] Hold Time from IDCK falling edge	EDGE = 0	1.5		ns
T_{SIDR}	Data, DE, VSYNC, HSYNC, and CTL[3:1] Setup Time to IDCK rising edge	EDGE = 1	1.5		ns
T_{HIDR}	Data, DE, VSYNC, HSYNC, and CTL[3:1] Hold Time from IDCK rising edge	EDGE = 1	1.5		ns
T_{DDF}	VSYNC, HSYNC, and CTL[3:1] Delay from DE falling edge ¹		T_{CIP}		ns
T_{DDR}	VSYNC, HSYNC, and CTL[3:1] Delay to DE rising edge ¹		T_{CIP}		ns
T_{HDE}	DE high time ¹			$8191T_{CIP}$	ns
T_{LDE}	DE low time ¹		$128T_{CIP}$		ns
T_{I2CDVD}	SDA Data Valid Delay from SCL high to low transition	$C_L = 400\text{pf}$		1000	ns
T_{RESET}	ISEL/RST Signal High Time required for valid I ² C reset		50		μs

Notes

1. Guaranteed by design.
2. All TMDS signaling is guaranteed to meet the DVI 1.0 specifications.
3. All Standard mode I²C (100kHz and 400kHz) timing requirements are guaranteed by design.

Input Timing Diagrams

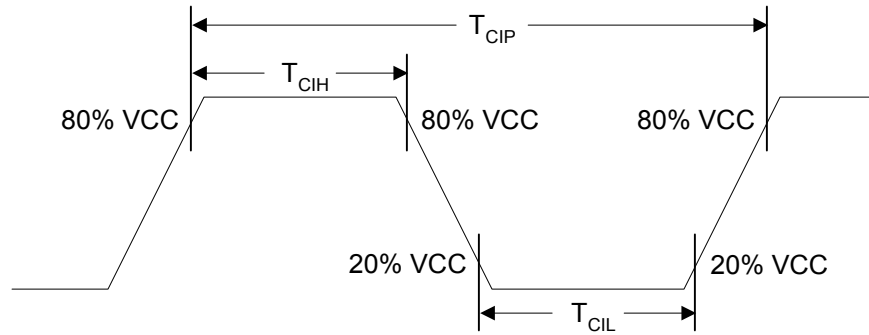

Figure 4. Clock Cycle High/Low Times

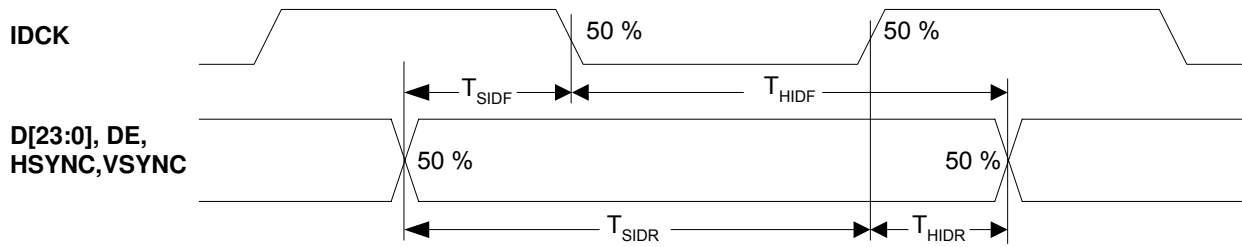

Figure 5. Input Data Setup/Hold Time to IDCK

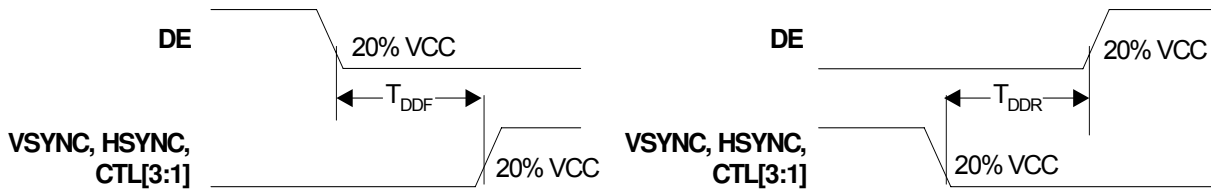

Figure 6. VSYNC, HSYNC and CTL[3:1] Delay Time from DE

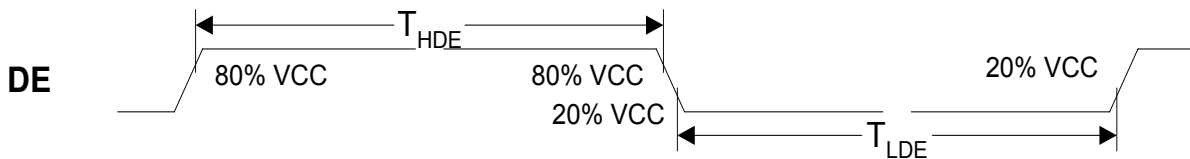

Figure 7. DE High and Low Times

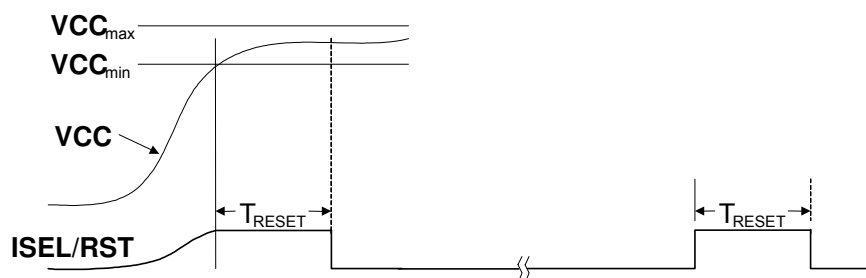

Figure 8. Reset Timing at Power-Up or Prior to First I²C Access

Pin Descriptions

Input Pins

Pin Name	Pin #	Type	Description
DIE23- DIE0	See SiI 1160 Pin Diagram	In	Input Even Data[23:0] corresponds to 24-bit pixel data for 1-pixel/clock input mode and to the first 24-bit pixel data for 2-pixels/clock mode. Input data is synchronized with Input data clock (IDCK). Data can be latched on the rising of the falling edge of IDCK depending on whether EDGE is high or low, respectively. Refer to TFT Panel Data Mapping in this document and DSTN Panel Data Mapping application note (SiI-AN-0007-A), which tabulates the relationship between the input data to the transmitter and output data from the Receiver
DIO23- DIO0	See SiI 1160 Pin Diagram	In	Input Odd Data[23:0] corresponds to the second 24-bit pixel data for 2-pixels/clock mode. Tie all pins to low when not in use. Input data is synchronized with Input data clock (IDCK). Data can be latched on the rising of the falling edge of IDCK depending on whether EDGE is high or low, respectively. Dual Link is not supported.
IDCK	80	In	Input Data Clock. Input data and control signals can be valid either on the falling or the rising edge of IDCK as selected by the EDGE pin.
DE	78	In	Input Data Enable. This signal qualifies the active data area. DE is always required by the transmitter and must be high during active display time and low during blanking time.
HSYNC	76	In	Horizontal Sync input control signal.
VSYNC	77	In	Vertical Sync input control signal.

Control and Configuration Pins

Pin Name	Pin #	Type	Description
EDGE	24	In	Data/Control Latching Edge. A LOW level indicates that all input signals(DIE/DIO[23:0], HSYNC, VSYNC, DE and CTL[3:1]) are latched on the falling edge of IDCK, while a HIGH level(3.3V) indicates that all input signals are latched on the rising edge of IDCK. When the I ² C interface is enabled (ISEL/RST=LOW), this pin is ignored and the EDGE register bit is used instead.
PIXS	25	In	Pixel Select. A LOW level indicates one pixel (up to 24-bits) per clock mode using DIE[23:0]. A HIGH level (3.3V) indicates two pixels (up to 48-bits) per clock mode using DIE[23:0] for the first pixel and DIO[23:0] for the second pixel.
CTL1	84	In	General Input control signal 1.
SS_CLK_IN		Spread Spectrum Clock Input (future). A planned future variation of this device will allow a spread spectrum version of SS_CLK_OUT to be driven into this pin, at which time pin 29 will become CTL1.	
CTL2	83	In	General Input control signal 2.
SS_CLK_OUT		Out	Spread Spectrum Clock Output (future). A planned future variation of this device will allow a clock to be driven out of this pin for conditioning by a spread spectrum device, at which time pin 28 will become CTL2.
CTL3	82	In	General Input control signal 3.
RSVD	27	In	Reserved. Must be tied HIGH for normal operation.
SS_EN#			Spread Spectrum Enable. A planned future variation of this device will use this pin to enable pins 83 and 84 to handle spread spectrum clock. Low = Spread Spectrum feature enabled on pins 83 and 84 High = Pins 83 and 84 are CTL2 and CTL1 outputs (default)

Power Management Pins

Pin Name	Pin #	Type	Description
PD	26	In	Power Down (active LOW). A HIGH level indicates normal operation. A LOW level indicates power down mode. During power down mode, all data (DIE/DIO[23:0]), data enable (DE), clock (IDCK) and control signals (HSYNC, VSYNC, CTL[3:1]), input buffers are disabled, all output buffers are tri-stated and all internal circuitry is powered down. When the I ² C interface is enabled (ISEL/RST=LOW), this pin is ignored and the PD register bit is used instead. Tie this pin low if not used.

Differential Signal Data Pins

Pin Name	Pin #	Type	Description
TX0+	40	Analog	TMDS Low Voltage Differential Signal input data pairs. These pins are tri-stated when PD is asserted.
TX0-	39	Analog	
TX1+	43	Analog	
TX1-	42	Analog	
TX2+	46	Analog	
TX2-	45	Analog	
TXC+	35	Analog	TMDS Low Voltage Differential Signal input clock pair. These pins are tri-stated when PD is asserted.
TXC-	34	Analog	
EXT_SWING	32	Analog	Voltage Swing Adjust. A resistor should tie this pin to AVCC. This resistor determines the amplitude of the voltage swing. A smaller resistor value sets a larger voltage swing and vice versa. For remote display applications with source termination, a 510Ω resistor is recommended (see page 24). Without the source termination, use a 560Ω resistor.

Local Control (I²C) Interface

The transmitter can operate with or without an I²C interface connection. Refer to the Feature Information section for details on using the I²C registers.

Pin Name	Pin #	Type	Description
ISEL/RST	87	In	I ² C Interface Select. If LOW, then the I ² C interface is active. If HIGH, the interface is inactive and chip configuration is taken from strap and default settings. This pin also acts as an asynchronous reset to the I ² C interface controller. Switching this input from HIGH to LOW after a minimum T _{RESET} high time resets the I ² C logic.
MSEN	21	Out	Monitor Sense. The behavior of this output depends on whether the I ² C interface is enabled or disabled. No I ² C (ISEL = HIGH) MSEN=HIGH: a powered on receiver is detected at the TMDS outputs. MSEN=LOW: a powered on receiver is not detected. This Receiver Sense function can only be used in DC-coupled systems. I ² C enabled (ISEL = LOW) The output is programmable through the I ² C interface and can indicate the Hot Plug or Receiver Sense signal state, or can instead generate a status change interrupt for those signals. This pin is an open collector output. An external pull-up resistor (5KΩ recommended) is required on this pin if the MSEN signal will be used. Otherwise the signal should be tied low.
SCL	20	In	I ² C Clock. When the I ² C interface is enabled (ISEL=LOW), this pin acts as the I ² C clock input. This pin is an open collector output. It must be pulled high to VCC through a resistor; a value of 2.2KΩ is recommended for I ² C applications, 2-5KΩ otherwise. This pin is not 5V-tolerant.
SDA	23	In/Out	I ² C Data. When the I ² C interface is enabled (ISEL=LOW), this pin acts as the I ² C data input and output. This pin is an open collector output. It must be pulled high to VCC through a resistor; a value of 2.2KΩ is recommended for I ² C applications, 2-5KΩ otherwise. This pin is not 5V-tolerant.

Reserved Pins

It is preferable to tie indicated pins HIGH through a 2-5K Ω resistor; direct connection to VCC is not recommended.

Pin Name	Pin #	Type	Description
RSVD	22	In	Reserved. Must be tied HIGH for normal operation.
RSVD	28	In	Reserved. Must be tied HIGH for normal operation.
RSVD	29	In	Reserved. Must be tied HIGH for normal operation.
RSVD	38	--	Reserved. Should be left unconnected (but can be tied to AVCC for existing SiI 160 designs).

Power and Ground Pins

Pin Name	Pin #	Type	Description
VCC	8,30,56,88	Power	Digital Core VCC, must be set to 3.3V.
GND	7,31,57,67,79,89	Ground	Digital Core GND.
IVCC	17,66,81,98	Power	Input VCC, must be set to 3.3V.
AVCC	36,44	Power	Analog VCC must be set to 3.3V.
AGND	33,37,41,47	Ground	Analog GND.
PVCC1	18	Power	Primary PLL Analog VCC must be set to 3.3V.
PVCC2	85	Power	Filter PLL Analog VCC must be set to 3.3V.
PGND1	19	Ground	PLL Analog GND. PGND1 should not be directly connected to PGND2 before being connected to the GROUND plane. They should be connected individually to the GROUND plane.
PGND2	86	Ground	PLL Analog GND. PGND2 should not be directly connected to PGND1 before being connected to the GROUND plane. They should be connected individually to the GROUND plane.

Feature Information

I²C Interface

The SiI 1160 Tx provides an I²C slave interface for more precise control of the chip features. Use of this interface is optional and is selected by the ISEL/RST pin. If not used, the chip register settings return to a default state; the EDGE and PD features then come under the control of the respective strap pins instead.

The I²C slave state machine operates from an internal clock derived from the incoming SCL signal. No video clock and input is required to read and write to the I²C registers from address 0x00 to 0x0F. These accesses can also take place using only the SCL clock in power down mode.

The transmitter responds to the seven-bit binary I²C address of 0x70. A read or write transaction is determined by bit 0 of the I²C address. Setting this bit to 0 will enable a write transaction and setting this bit to 1 will enable a read transaction.

The I²C read operation is shown in Figure 9, and the write operation in Figure 10. Page mode is not supported.

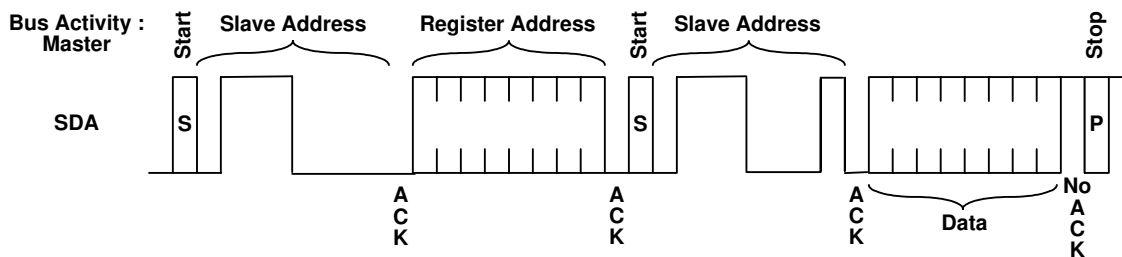

Figure 9. I²C Byte Read

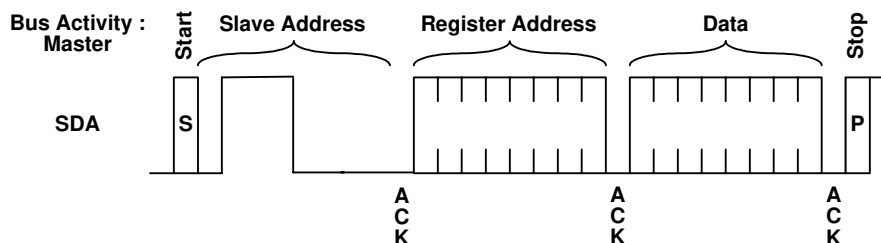

Figure 10. I²C Byte Write

I²C Register Mapping

Addr.	Bit 7	Bit 6	Bit 5	Bit 4	Bit 3	Bit 2	Bit 1	Bit 0	Default Value	Notes
0x0	VND_IDL								0x01	
0x1	VND_IDH								0x00	
0x2	DEV_IDL								0x06	
0x3	DEV_IDH								0x00	
0x4	DEV_REV								0x00	
0x5	RSVD									4
0x6	FRQ_LOW								0x19	
0x7	FRQ_HIGH								0x64	
0x8	RSVD write to 00		VEN	HEN	RSVD write to 01		EDGE	PD	00110100	3, 5, 6
0x9	RSVD					RSEN	RSVD		read only	
0xA	RSVD write to 1000000							CTL0	10000001	5, 6
0xB- 0xD	RSVD									4
0xE	RSVD write to 00		EZONE	ZONEF	ZONEO	RSVD write to 001			00000001	
0xF	RSVD									4

Notes:

- Hexadecimal values use a prefix of '0x'. All values use bit 7 as most significant, bit 0 as least significant.
- Read-only or read/write capabilities are noted on the next page.
- On any reset assertion event, registers that have default values lose their previously programmed value and are set back to the default values listed.
- Registers listed as RSVD and shaded gray are reserved for factory use and should not be accessed.
- Write RSVD bits to the values indicated when writing other bits in the register.
- Write PD to 1 for normal operation; write CTL0 to 0 for HDMI applications.

Table 1. General I²C Register Bits

Register Name	Access	Description
VND_IDL	RO	Vendor ID Low byte (0x01)
VND_IDH	RO	Vendor ID High byte (0x00)
DEV_IDL	RO	Device ID Low byte (0x06)
DEV_IDH	RO	Device ID High byte (0x00)
DEV_REV	RO	Device Revision (0x00)
FRQ_LOW	RO	IDCK. Low frequency limit is 25MHz. (0x19)
FRQ_HIGH	RO	IDCK High frequency limit is 165MHz. Value is offset over 65MHz. (0x64)
HEN	RW	Horizontal Sync Enable 0 – HSYNC input is transmitted as fixed LOW 1 – HSYNC input is transmitted as input. → Default
VEN	RW	Vertical Sync Enable 0 – VSYNC input is transmitted as fixed LOW 1 – VSYNC input is transmitted as input. → Default
EDGE	RW	Edge Select (same function as EDGE pin) 0 – Input data low order bits latched first → Default 1 – Input data high order bits latched first
PD	RW	Power Down mode (same function as PD# pin) 0 – Power Down. → Default after RESET 1 – Normal operation
RSEN	RO	Receiver Sense. This bit is HIGH if a powered on receiver is connected to the transmitter outputs, LOW otherwise. This function is only available for use in DC-coupled systems.
CTL0	RW	Control 0. CTL0, CTL1, CTL2, CTL3 are sent over TMDS interface when DE is LOW. CTL1-3 are driven in from external pins, but CTL0 is not available externally and therefore must be set through this register. Set to 0 for HDMI applications. 0 – Transmit CTL0 as LOW 1 – Transmit CTL0 as HIGH Note that when not in I ² C mode, CTL0 is always transmitted as HIGH.

Notes:

1. RO = Read Only Registers
2. RW = Read/Write Registers
3. 'Default' indicates value set after a reset event. Not all bits default to a defined state after reset.

Dual Zone PLL

The SiI 1160 Tx offers a dual-zone PLL that changes its operational parameters depending on the frequency zone selected. In the low zone, operation is ideal in the low frequency range, from 20MHz to around 120MHz. High zone operation is optimized in the high frequency range, above 100MHz. In the overlapping range, either low zone or high zone operation can be used.

Operating zone optimization contributes to robust operation over long cables. For example, optimized PLL characteristics account for the ability of the transmitter to send video at UXGA over 20m cables.

PLL zone selection is controlled either manually or automatically. Manual zone control is the preferred mode of operation.

Manual Zone Control

Whenever the application allows it, PLL zone selection should be made manually. The I²C register bits ZONEF and EZONE allow the host graphics controller to set the optimal zone for the current video resolution being transmitted. For frequencies over 100MHz, the controller should select high zone PLL operation. Table 2 describes the relevant register bits.

Automatic Zone Control

For applications that are not able to program the I²C registers, the chip incorporates an automatic zone control circuit. This circuit determines whether the input pixel clock is operating in the low frequency range or the high frequency range, and sets the PLL zone selection accordingly. The chip defaults to the automatic mode of zone selection after reset.

The zone determination depends primarily on input frequency, but is also affected by operating voltage and chip temperature. Therefore, it is possible for an automatic zone switch to occur while video input is stable, causing momentary (~1 μ s) unevenness in the video output clock and data streams. This could occur, for example, while the chip is still warming up to its normal operating temperature. However, the automatic selection circuit provides wide hysteresis to ensure that there will not be any oscillation around the zone switch point.

Table 2. Dual Zone PLL I²C Control Register Bits

Register Name	Access	Description
ZONEF	RW	Zone Force. Enable external selection of main PLL operating zone. When ZONEF=1, the main PLL zone is selected by EZONE. 0 – Automatic zone selection – EZONE bit disabled (default) 1 – Manual zone selection – EZONE bit enabled
EZONE	RW	External Zone Select. Selects operating zone of main PLL, but only when ZONEF=1 (disabled by default). 0 – Low zone (recommended for 20-120MHz) 1 – High zone (recommended for > 100MHz)
ZONEO	RO	Zone Output – indicates current operating zone. When ZONEF=0 (automatic), ZONEO indicates that PLL is operating in zone optimized for: 0 = Lower frequencies 1 = Higher frequencies. When ZONEF=1 (manual), ZONEO information is not used.

Reset Description

The input pin ISEL/RST serves as an asynchronous reset for the I²C slave controller in I²C mode. The programming registers, which are accessible over the I²C bus, lose their previously programmed values as soon as ISEL/RST is switched from HIGH to LOW. I²C registers whose default values are not correct for normal operation must then be manually set to their appropriate value.

ISEL/RST serves only to set the registers to their default values, and to restore the interface to a known initial state. Without an initial reset, the I²C interface may not respond properly. The minimum ISEL/RST high time for proper reset, after nominal VCC values have been reached, is T_{RESET}.

Register bit function PD is disabled after reset to eliminate any unexpected chip output before initialization. The state of this bit is set during the reset period according to the following rule: After a reset, the chip is turned off; the power down control bit, PD, is forced to 0. When the chip comes out of reset (ISEL/RST goes LOW), the TMDS outputs will be disabled and the transmitter will be turned off. To turn the transmitter back on, the PD bit must be set to 1 over the I²C bus.

TFT Panel Data Mapping

The following TFT data mapping tables are strictly listed for single link TFT applications only. For DSTN mapping please refer to Application Note SiI-AN-0007-A. SiI 1151 and SiI 1161 have the same pinout.

Table 3. One Pixel/Clock Input/Output TFT Mode

TFT VGA Output		Tx Input Data		Rx Output Data		TFT Panel Input	
24-bpp	18-bpp	1160	164	1161	141B	24-bpp	18-bpp
B0		DIE0	D0	QE0	Q0	B0	
B1		DIE1	D1	QE1	Q1	B1	
B2	B0	DIE2	D2	QE2	Q2	B2	B0
B3	B1	DIE3	D3	QE3	Q3	B3	B1
B4	B2	DIE4	D4	QE4	Q4	B4	B2
B5	B3	DIE5	D5	QE5	Q5	B5	B3
B6	B4	DIE6	D6	QE6	Q6	B6	B4
B7	B5	DIE7	D7	QE7	Q7	B7	B5
G0		DIE8	D8	QE8	Q8	G0	
G1		DIE9	D9	QE9	Q9	G1	
G2	G0	DIE10	D10	QE10	Q10	G2	G0
G3	G1	DIE11	D11	QE11	Q11	G3	G1
G4	G2	DIE12	D12	QE12	Q12	G4	G2
G5	G3	DIE13	D13	QE13	Q13	G5	G3
G6	G4	DIE14	D14	QE14	Q14	G6	G4
G7	G5	DIE15	D15	QE15	Q15	G7	G5
R0		DIE16	D16	QE16	Q16	R0	
R1		DIE17	D17	QE17	Q17	R1	
R2	R0	DIE18	D18	QE18	Q18	R2	R0
R3	R1	DIE19	D19	QE19	Q19	R3	R1
R4	R2	DIE20	D20	QE20	Q20	R4	R2
R5	R3	DIE21	D21	QE21	Q21	R5	R3
R6	R4	DIE22	D22	QE22	Q22	R6	R4
R7	R5	DIE23	D23	QE23	Q23	R7	R5
Shift CLK	Shift CLK	IDCK	IDCK	ODCK	ODCK	Shift CLK	Shift CLK
VSYNC	VSYNC	VSYNC	VSYNC	VSYNC	VSYNC	VSYNC	VSYNC
HSYNC	HSYNC	HSYNC	HSYNC	HSYNC	HSYNC	HSYNC	HSYNC
DE	DE	DE	DE	DE	DE	DE	DE

For 18-bit mode, the Flat Panel Graphics Controller interfaces to the transmitter exactly the same as in the 24-bit mode; however, 6 bits per channel (color) are used instead of 8. It is recommended that unused data bits be tied low. As can be seen from the above table, the data mapping for less than 24-bit per pixel interfaces are MSB justified. The data is sent during active display time while the control signals are sent during blank time. Note that the three data channels (CH0, CH1, CH2) are mapped to Blue, Green and Red data respectively.

Table 4. Two Pixels/Clock Input/Output TFT Mode

TFT VGA Output		Tx Input Data	Rx Output Data	TFT Panel Input	
24-bpp	18-bpp	1160	1161	24-bpp	18-bpp
B0 - 0		DIE0	QE0	B0 - 0	
B1 - 0		DIE1	QE1	B1 - 0	
B2 - 0	B0 - 0	DIE2	QE2	B2 - 0	B0 - 0
B3 - 0	B1 - 0	DIE3	QE3	B3 - 0	B1 - 0
B4 - 0	B2 - 0	DIE4	QE4	B4 - 0	B2 - 0
B5 - 0	B3 - 0	DIE5	QE5	B5 - 0	B3 - 0
B6 - 0	B4 - 0	DIE6	QE6	B6 - 0	B4 - 0
B7 - 0	B5 - 0	DIE7	QE7	B7 - 0	B5 - 0
G0 - 0		DIE8	QE8	G0 - 0	
G1 - 0		DIE9	QE9	G1 - 0	
G2 - 0	G0 - 0	DIE10	QE10	G2 - 0	G0 - 0
G3 - 0	G1 - 0	DIE11	QE11	G3 - 0	G1 - 0
G4 - 0	G2 - 0	DIE12	QE12	G4 - 0	G2 - 0
G5 - 0	G3 - 0	DIE13	QE13	G5 - 0	G3 - 0
G6 - 0	G4 - 0	DIE14	QE14	G6 - 0	G4 - 0
G7 - 0	G5 - 0	DIE15	QE15	G7 - 0	G5 - 0
R0 - 0		DIE16	QE16	R0 - 0	
R1 - 0		DIE17	QE17	R1 - 0	
R2 - 0	R0 - 0	DIE18	QE18	R2 - 0	R0 - 0
R3 - 0	R1 - 0	DIE19	QE19	R3 - 0	R1 - 0
R4 - 0	R2 - 0	DIE20	QE20	R4 - 0	R2 - 0
R5 - 0	R3 - 0	DIE21	QE21	R5 - 0	R3 - 0
R6 - 0	R4 - 0	DIE22	QE22	R6 - 0	R4 - 0
R7 - 0	R5 - 0	DIE23	QE23	R7 - 0	R5 - 0
B0 - 1		DIO0	QO0	B0 - 1	
B1 - 1		DIO1	QO1	B1 - 1	
B2 - 1	B0 - 1	DIO2	QO2	B2 - 1	B0 - 1
B3 - 1	B1 - 1	DIO3	QO3	B3 - 1	B1 - 1
B4 - 1	B2 - 1	DIO4	QO4	B4 - 1	B2 - 1
B5 - 1	B3 - 1	DIO5	QO5	B5 - 1	B3 - 1
B6 - 1	B4 - 1	DIO6	QO6	B6 - 1	B4 - 1
B7 - 1	B5 - 1	DIO7	QO7	B7 - 1	B5 - 1
G0 - 1		DIO8	QO8	G0 - 1	
G1 - 1		DIO9	QO9	G1 - 1	
G2 - 1	G0 - 1	DIO10	QO10	G2 - 1	G0 - 1
G3 - 1	G1 - 1	DIO11	QO11	G3 - 1	G1 - 1
G4 - 1	G2 - 1	DIO12	QO12	G4 - 1	G2 - 1
G5 - 1	G3 - 1	DIO13	QO13	G5 - 1	G3 - 1
G6 - 1	G4 - 1	DIO14	QO14	G6 - 1	G4 - 1
G7 - 1	G5 - 1	DIO15	QO15	G7 - 1	G5 - 1
R0 - 1		DIO16	QO16	R0 - 1	
R1 - 1		DIO17	QO17	R1 - 1	
R2 - 1	R0 - 1	DIO18	QO18	R2 - 1	R0 - 1
R3 - 1	R1 - 1	DIO19	QO19	R3 - 1	R1 - 1
R4 - 1	R2 - 1	DIO20	QO20	R4 - 1	R2 - 1
R5 - 1	R3 - 1	DIO21	QO21	R5 - 1	R3 - 1
R6 - 1	R4 - 1	DIO22	QO22	R6 - 1	R4 - 1
R7 - 1	R5 - 1	DIO23	QO23	R7 - 1	R5 - 1
ShiftClk/2	ShiftClk/2	IDCK	ODCK	Shift CLK	Shift CLK
VSYNC	VSYNC	VSYNC	VSYNC	VSYNC	VSYNC
HSYNC	HSYNC	HSYNC	HSYNC	HSYNC	HSYNC
DE	DE	DE	DE	DE	DE

Table 5. 24-bit One Pixel/Clock Input with 24-bit Two Pixels/Clock Output TFT Mode

TFT VGA Output 24-bpp	Tx Input Data		Rx Output Data	TFT Panel Input 24-bpp
	1160	164	1161	
B0	DIE0	D0	QE0	B0 - 0
B1	DIE1	D1	QE1	B1 - 0
B2	DIE2	D2	QE2	B2 - 0
B3	DIE3	D3	QE3	B3 - 0
B4	DIE4	D4	QE4	B4 - 0
B5	DIE5	D5	QE5	B5 - 0
B6	DIE6	D6	QE6	B6 - 0
B7	DIE7	D7	QE7	B7 - 0
G0	DIE8	D8	QE8	G0 - 0
G1	DIE9	D9	QE9	G1 - 0
G2	DIE10	D10	QE10	G2 - 0
G3	DIE11	D11	QE11	G3 - 0
G4	DIE12	D12	QE12	G4 - 0
G5	DIE13	D13	QE13	G5 - 0
G6	DIE14	D14	QE14	G6 - 0
G7	DIE15	D15	QE15	G7 - 0
R0	DIE16	D16	QE16	R0 - 0
R1	DIE17	D17	QE17	R1 - 0
R2	DIE18	D18	QE18	R2 - 0
R3	DIE19	D19	QE19	R3 - 0
R4	DIE20	D20	QE20	R4 - 0
R5	DIE21	D21	QE21	R5 - 0
R6	DIE22	D22	QE22	R6 - 0
R7	DIE23	D23	QE23	R7 - 0
			QO0	B0 - 1
			QO1	B1 - 1
			QO2	B2 - 1
			QO3	B3 - 1
			QO4	B4 - 1
			QO5	B5 - 1
			QO6	B6 - 1
			QO7	B7 - 1
			QO8	G0 - 1
			QO9	G1 - 1
			QO10	G2 - 1
			QO11	G3 - 1
			QO12	G4 - 1
			QO13	G5 - 1
			QO14	G6 - 1
			QO15	G7 - 1
			QO16	R0 - 1
			QO17	R1 - 1
			QO18	R2 - 1
			QO19	R3 - 1
			QO20	R4 - 1
			QO21	R5 - 1
			QO22	R6 - 1
			QO23	R7 - 1
Shift CLK	IDCK	IDCK	ODCK	Shift CLK/2
VSYNC	VSYNC	VSYNC	VSYNC	VSYNC
HSYNC	HSYNC	HSYNC	HSYNC	HSYNC
DE	DE	DE	DE	DE

Table 6. 18-bit One Pixel/Clock Input with 18-bit Two Pixels/Clock Output TFT Mode

TFT VGA Output 18-bpp	Tx Input Data		Tx Output Data		TFT Panel Input 18-bpp
	1160	164	1161	141B	
	DIE0	D0	QE0		
	DIE1	D1	QE1		
B0	DIE2	D2	QE2	Q0	B0 - 0
B1	DIE3	D3	QE3	Q1	B1 - 0
B2	DIE4	D4	QE4	Q2	B2 - 0
B3	DIE5	D5	QE5	Q3	B3 - 0
B4	DIE6	D6	QE6	Q4	B4 - 0
B5	DIE7	D7	QE7	Q5	B5 - 0
	DIE8	D8	QE8		
	DIE9	D9	QE9		
G0	DIE10	D10	QE10	Q6	G0 - 0
G1	DIE11	D11	QE11	Q7	G1 - 0
G2	DIE12	D12	QE12	Q8	G2 - 0
G3	DIE13	D13	QE13	Q9	G3 - 0
G4	DIE14	D14	QE14	Q10	G4 - 0
G5	DIE15	D15	QE15	Q11	G5 - 0
	DIE16	D16	QE16		
	DIE17	D17	QE17		
R0	DIE18	D18	QE18	Q12	R0 - 0
R1	DIE19	D19	QE19	Q13	R1 - 0
R2	DIE20	D20	QE20	Q14	R2 - 0
R3	DIE21	D21	QE21	Q15	R3 - 0
R4	DIE22	D22	QE22	Q16	R4 - 0
R5	DIE23	D23	QE23	Q17	R5 - 0
			Q00		
			Q01		
			Q02	Q18	B0 - 1
			Q03	Q19	B1 - 1
			Q04	Q20	B2 - 1
			Q05	Q21	B3 - 1
			Q06	Q22	B4 - 1
			Q07	Q23	B5 - 1
			Q08		
			Q09		
			Q010	Q24	G0 - 1
			Q011	Q25	G1 - 1
			Q012	Q26	G2 - 1
			Q013	Q27	G3 - 1
			Q014	Q28	G4 - 1
			Q015	Q29	G5 - 1
			Q016		
			Q017		
			Q018	Q30	R0 - 1
			Q019	Q31	R1 - 1
			Q020	Q32	R2 - 1
			Q021	Q33	R3 - 1
			Q022	Q34	R4 - 1
			Q023	Q35	R5 - 1
Shift CLK	IDCK	IDCK	ODCK	Shift CLK/2	Shift CLK/2
VSYNC	VSYNC	VSYNC	VSYNC	VSYNC	VSYNC
HSYNC	HSYNC	HSYNC	HSYNC	HSYNC	HSYNC
DE	DE	DE	DE	DE	DE

Table 7. Two Pixels/Clock Input with One Pixel/Clock Output TFT Mode

TFT VGA Output		Tx Input Data	Rx Output Data			TFT Panel Input	
24-bpp	18-bpp	1160	1161	141B	24-bpp	18-bpp	
B0 - 0		DIE0	QE0	Q0	B0		
B1 - 0		DIE1	QE1	Q1	B1		
B2 - 0	B0 - 0	DIE2	QE2	Q2	B2	B0	
B3 - 0	B1 - 0	DIE3	QE3	Q3	B3	B1	
B4 - 0	B2 - 0	DIE4	QE4	Q4	B4	B2	
B5 - 0	B3 - 0	DIE5	QE5	Q5	B5	B3	
B6 - 0	B4 - 0	DIE6	QE6	Q6	B6	B4	
B7 - 0	B5 - 0	DIE7	QE7	Q7	B7	B5	
G0 - 0		DIE8	QE8	Q8	G0		
G1 - 0		DIE9	QE9	Q9	G1		
G2 - 0	G0 - 0	DIE10	QE10	Q10	G2	G0	
G3 - 0	G1 - 0	DIE11	QE11	Q11	G3	G1	
G4 - 0	G2 - 0	DIE12	QE12	Q12	G4	G2	
G5 - 0	G3 - 0	DIE13	QE13	Q13	G5	G3	
G6 - 0	G4 - 0	DIE14	QE14	Q14	G6	G4	
G7 - 0	G5 - 0	DIE15	QE15	Q15	G7	G5	
R0 - 0		DIE16	QE16	Q16	R0		
R1 - 0		DIE17	QE17	Q17	R1		
R2 - 0	R0 - 0	DIE18	QE18	Q18	R2	R0	
R3 - 0	R1 - 0	DIE19	QE19	Q19	R3	R1	
R4 - 0	R2 - 0	DIE20	QE20	Q20	R4	R2	
R5 - 0	R3 - 0	DIE21	QE21	Q21	R5	R3	
R6 - 0	R4 - 0	DIE22	QE22	Q22	R6	R4	
R7 - 0	R5 - 0	DIE23	QE23	Q23	R7	R5	
B0 - 1		DIO0					
B1 - 1		DIO1					
B2 - 1	B0 - 1	DIO2					
B3 - 1	B1 - 1	DIO3					
B4 - 1	B2 - 1	DIO4					
B5 - 1	B3 - 1	DIO5					
B6 - 1	B4 - 1	DIO6					
B7 - 1	B5 - 1	DIO7					
G0 - 1		DIO8					
G1 - 1		DIO9					
G2 - 1	G0 - 1	DIO10					
G3 - 1	G1 - 1	DIO11					
G4 - 1	G2 - 1	DIO12					
G5 - 1	G3 - 1	DIO13					
G6 - 1	G4 - 1	DIO14					
G7 - 1	G5 - 1	DIO15					
R0 - 1		DIO16					
R1 - 1		DIO17					
R2 - 1	R0 - 1	DIO18					
R3 - 1	R1 - 1	DIO19					
R4 - 1	R2 - 1	DIO20					
R5 - 1	R3 - 1	DIO21					
R6 - 1	R4 - 1	DIO22					
R7 - 1	R5 - 1	DIO23					
ShiftClk/2	ShiftClk/2	IDCK	ODCK	ODCK	ShiftClk	ShiftClk	
VSYNC	VSYNC	VSYNC	VSYNC	VSYNC	VSYNC	VSYNC	
HSYNC	HSYNC	HSYNC	HSYNC	HSYNC	HSYNC	HSYNC	
DE	DE	DE	DE	DE	DE	DE	

Design Recommendations

Differences Between SiI 160 and SiI 1160

The SiI 1160 Tx is a pin-compatible upgrade to the SiI 160 Tx. It provides improved cable length support without any changes to the pinout. Interrupt capability is also a new option using the optional MSEN pin. The SiI 1160 Tx can also act as to repeat HDMI signals when its internal registers are programmed appropriately; this application requires the use of an I²C interface, optionally available on the SDA and SCL pins.

Table 8. New Pin Functions for SiI 1160 Tx

Pin	SiI 160	SiI 1160
20	RSVD – Tied HIGH	Optional I ² C interface pin SCL
21	RSVD – Tied LOW	Optional interrupt output MSEN
23	RSVD – Tied HIGH	Optional I ² C interface pin SDA
87	RSVD – Tied HIGH	ISEL/RST

EXT_SWING Selection

The recommended R_{EXT_SWING} resistor value for the EXT_SWING pin is provided in the Pin Descriptions section. This value can be adjusted as needed to optimize the DVI signal swing levels according to the needs of the application. This adjustment might become necessary, for example, when deviating from the recommended source termination values (described in the Source Termination Resistors on Differential Outputs section) to optimize for a specific cabling environment.

PCB Ground Planes

All ground pins on the device should be connected to the same, contiguous ground plane in the PCB. This helps to avoid ground loops and inductances from one ground plane segment to another. Such low-inductance ground paths are critical for return currents, which affect EMI performance. The entire ground plane surrounding the PanelLink transmitter should be one piece, and include the ground vias for the DVI connector.

Voltage Ripple Regulation

The power supply to PVCC is very important to the proper operation of the Transmitter chips. PVCC does not draw much current so any voltage regulator that can supply 50mA or more is sufficient. A suggested regulator circuit using a low-dropout regulator is shown in Figure 11. Note that alternative voltage regulator circuits should be considered only if they meet the LM317 standards of line/load regulation.

Decoupling and bypass capacitors are also involved with power supply connections, as described in detail in Figure 14 and Figure 15.

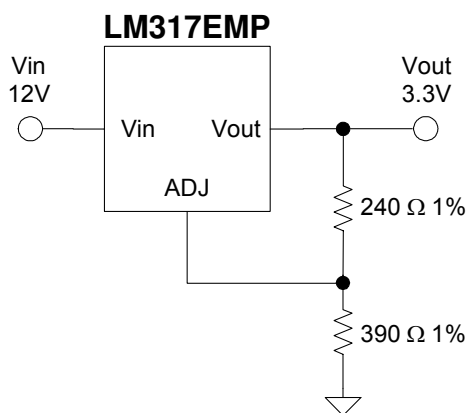

Figure 11. Voltage Regulation using LM317EMP

Spread Spectrum Support

TMDS architecture is inherently jitter-tolerant. Spread spectrum clocking can be applied to the clock and parallel data inputs of the SiI 1160 to allow for reduced EMI. The spread will be propagated throughout the system due to TMDS clock architecture, which passes nearly all low-frequency components of the incoming clock without attenuation. The amount of spread that can be applied without affecting the DVI eye is limited to $\pm 0.5\%$ with the current part, depending on the spreading algorithm employed by the external spread spectrum device.

A planned future variation of this chip will allow its internal clock to be coupled directly to a spread spectrum device. The expected result will be the ability to accommodate larger amounts of spread, and it will also work in 48-bit mode as well as 24-bit mode. Designs should make accommodations using pins 27, 83, and 84 as noted in the Pin Descriptions section so that the planned part can become a drop-in replacement for the SiI 1160.

Figure 12 illustrates how a design can anticipate the expected future chip version. Contact PhaseLink Corporation for additional information on their spread spectrum device.

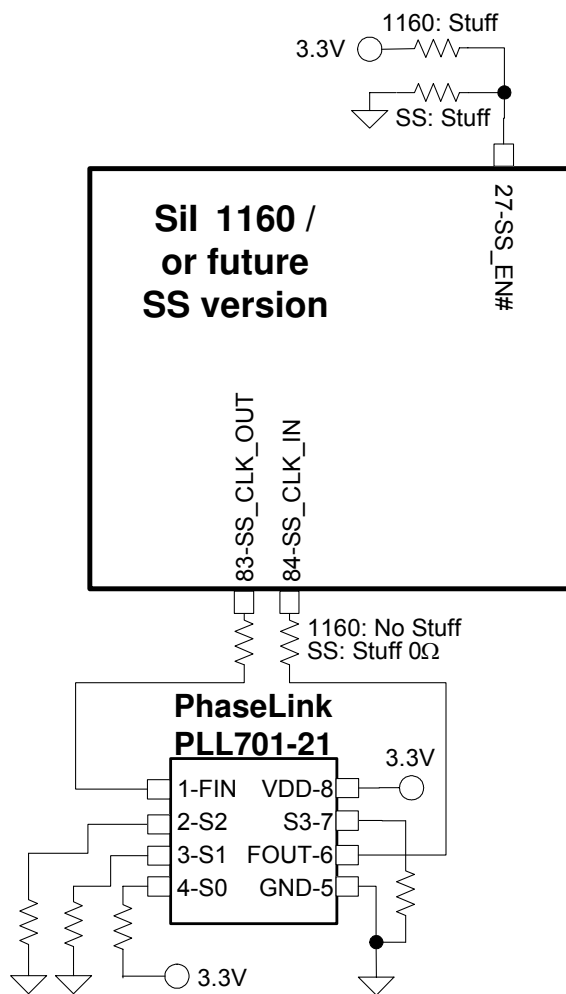

Figure 12. Planned Spread Spectrum Support Circuit