



Chipsmall Limited consists of a professional team with an average of over 10 year of expertise in the distribution of electronic components. Based in Hongkong, we have already established firm and mutual-benefit business relationships with customers from,Europe,America and south Asia,supplying obsolete and hard-to-find components to meet their specific needs.

With the principle of “Quality Parts,Customers Priority,Honest Operation,and Considerate Service”,our business mainly focus on the distribution of electronic components. Line cards we deal with include Microchip,ALPS,ROHM,Xilinx,Pulse,ON,Everlight and Freescale. Main products comprise IC,Modules,Potentiometer,IC Socket,Relay,Connector.Our parts cover such applications as commercial,industrial, and automotives areas.

We are looking forward to setting up business relationship with you and hope to provide you with the best service and solution. Let us make a better world for our industry!



Contact us

Tel: +86-755-8981 8866 Fax: +86-755-8427 6832

Email & Skype: info@chipsmall.com Web: www.chipsmall.com

Address: A1208, Overseas Decoration Building, #122 Zhenhua RD., Futian, Shenzhen, China



High Voltage 3-Phase Motor Driver ICs

Features and Benefits

- Built-in pre-drive IC
- MOSFET or IGBT power element
- Alleviate noise generation by adjusting an internal resistor
- CMOS compatible input (3.3 V and 5 V)
- High-side gate driver using bootstrap circuit or floating power supply
- Built-in protection circuit for controlling power supply voltage drop (UVLO on VBB and VCC)
- Overcurrent protection (OCP), overcurrent limiting (OCL), and thermal shutdown (TSD)
- Output of fault signal during operation of protection circuit
- Output current 2.5 A, 3.0 A, or 5 A
- Small DIP (SIM 40-pin)
- Isolation rating of 1500 Vrms/min.
- UL recognized component, File No.: E118037

Package: 40-pin DIP

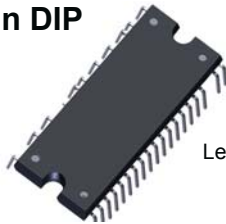

Leadform 2971

Not to scale



Description

The SIM6800M Series inverter power module (IPM) provides a robust, highly-integrated solution for optimally controlling 3-phase motor power inverter systems and variable speed control systems used in energy-conserving designs to drive motors of residential and commercial appliances. This IC takes up to 5 A (continuous) output current. It can withstand voltages of up to 600 V (IGBT breakdown voltage).

The SIM6800M Series series power package includes an IC with all of the necessary power elements (six MOSFETs or IGBTs and six freewheeling diodes), pre-driver ICs (two), and bootstrap diodes (three), needed to configure the main circuit of an inverter. This enables the main circuit of the inverter to be configured with fewer external components than traditional designs.

Applications include residential white goods (home applications) and commercial appliance motor control:

- Air conditioner fan
- Small ventilation fan
- Dishwasher pump

Functional Block Diagram

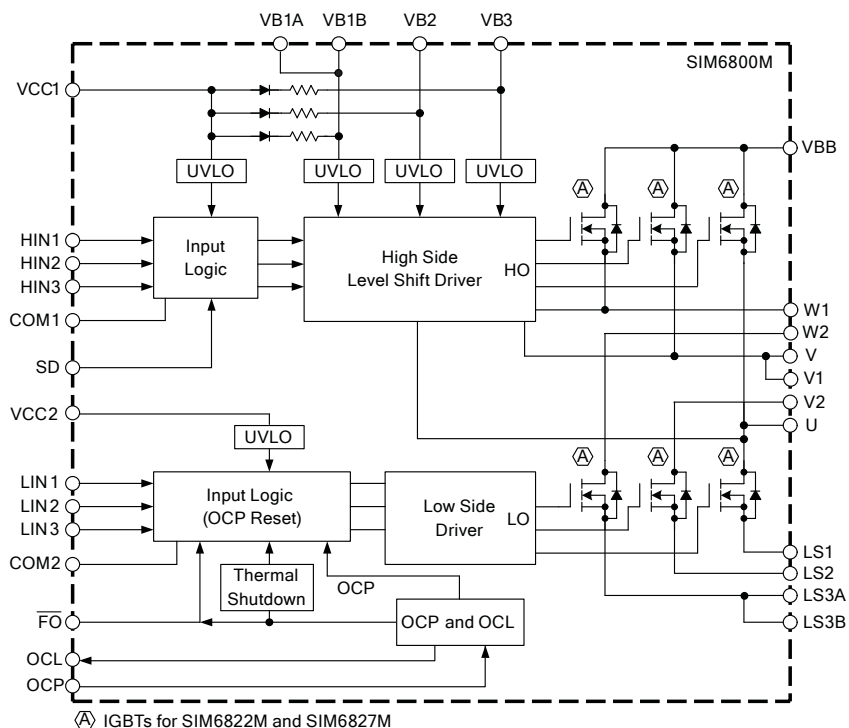

Selection Guide

Part Number	Power Device Rating					Boot Resistance (Ω)	Input Voltage (VAC)	Note
	Type	Breakdown (V)	Output (A)	$V_{CE(sat)}$ (V)				
				(Typ)	(Max)			
SIM6812M	MOSFET	500	2.5	2.0	2.4	60	200	
SIM6813M	MOSFET	500	3.0	1.4	1.7	60	200	
SIM6822M	IGBT	600	5.0	1.75	2.2	60	200	Low switching loss
SIM6827M								Low noise

Recommended Operating Conditions

Characteristic	Symbol	Remarks		Min.	Typ.	Max.	Units
Main Supply Voltage	V_{BB}	SIM6812M SIM6813M	Between V_{BB} and LS	–	–	400	V
		SIM6822M SIM6827M		–	–	400	V
Logic Supply Voltage	V_{CC}		Between V_{CC} and COM	13.5	15	16.5	V
Dead Time	t_{dead}			1.5	–	–	μ s
Bootstrap Capacitor	C_{BOOT}			1	–	–	μ F
Pull-up Resistor \overline{FO} Pin	R_{FO}			3.3	–	10	k Ω
Capacitor \overline{FO} Pin	C_{FO}			0.001	–	0.01	μ F
Shunt Resistor LS Pin	R_S	SIM6812M SIM6813M	$V_{LS} \leq 1$ V	0.33	–	–	Ω
Switching Frequency	f_{PWM}	SIM6822M SIM6827M		–	–	20	kHz

SIM6812M and SM6813M Absolute Maximum Ratings, valid at $T_A = 25^\circ\text{C}$

Characteristic	Symbol	Remarks	Rating	Unit
MOSFET Breakdown Voltage	V_{DSS}	$I_D = 100 \mu\text{A}$	500	V
Logic Supply Voltage	V_{CC}	Between VCC and COM	20	V
Bootstrap Voltage	V_{BS}	Between VB and HS (U,V, and W phases)	20	V
Output Current, Continuous	I_O	SIM6812M $T_C = 25^\circ\text{C}$	2.5	A
		SIM6813M $T_C = 25^\circ\text{C}$	3.0	A
Output Current, Pulsed	I_{OP}	SIM6812M $PW \leq 100 \mu\text{s}$, duty cycle = 1%	3.75	A
		SIM6813M $PW \leq 100 \mu\text{s}$, duty cycle = 1%	4.5	A
Input Voltage	V_{IN}	HINx, LINx, and OCP pins	-0.5 to 7	V
Thermal Resistance (Junction to Case)	$R_{\theta JC(IGBT)}$	All elements operating	3.6	$^\circ\text{C/W}$
Thermal Resistance (Junction to Ambient)	$R_{\theta JA(IGBT)}$	All elements operating	25	$^\circ\text{C/W}$
Case Operating Temperature	T_{COP}		-20 to 100	$^\circ\text{C}$
Storage Temperature	T_{stg}		-40 to 150	$^\circ\text{C}$
Isolation Voltage	V_{iso}	Between marked side of device and each pin, 1 minute, AC	1500	V_{rms}

SIM6822M and SIM6827M Absolute Maximum Ratings, valid at $T_A = 25^\circ\text{C}$

Characteristic	Symbol	Remarks	Rating	Unit
Supply Voltage	V_{DC}	Between VBB and LS1, LS2, and LS3	450	V
Supply Voltage (Surge)	$V_{DC(Surge)}$	Between VBB and LS1, LS2, and LS3	500	V
IGBT Breakdown Voltage	V_{CES}	$I_C = 1 \text{ mA}$	600	V
Logic Supply Voltage	V_{CC}	Between VCC and COM	20	V
Bootstrap Voltage	V_{BS}	Between VB and HS (U,V, and W phases)	20	V
Output Current, Continuous	I_O		5.0	A
Output Current, Pulsed	I_{OP}	$PW \leq 100 \mu\text{s}$, duty cycle = 1%	7.5	A
Input Voltage	V_{IN}	HINx, LINx, and OCP pins	-0.5 to 7	V
Thermal Resistance (Junction to Case)	$R_{\theta JC(IGBT)}$	IGBT, all elements operating	3.6	$^\circ\text{C/W}$
	$R_{\theta JC(FRG)}$	FRG, all elements operating	4.2	$^\circ\text{C/W}$
Thermal Resistance (Junction to Ambient)	$R_{\theta JA(IGBT)}$	IGBT, all elements operating	25	$^\circ\text{C/W}$
	$R_{\theta JA(FRG)}$	FRG, all elements operating	29	$^\circ\text{C/W}$
Case Operating Temperature	T_{COP}		-20 to 100	$^\circ\text{C}$
Storage Temperature	T_{stg}		-40 to 150	$^\circ\text{C}$
Isolation Voltage	V_{iso}	Between marked side of device and each pin, 1 minute, AC	1500	V_{rms}

Typical Application Diagram

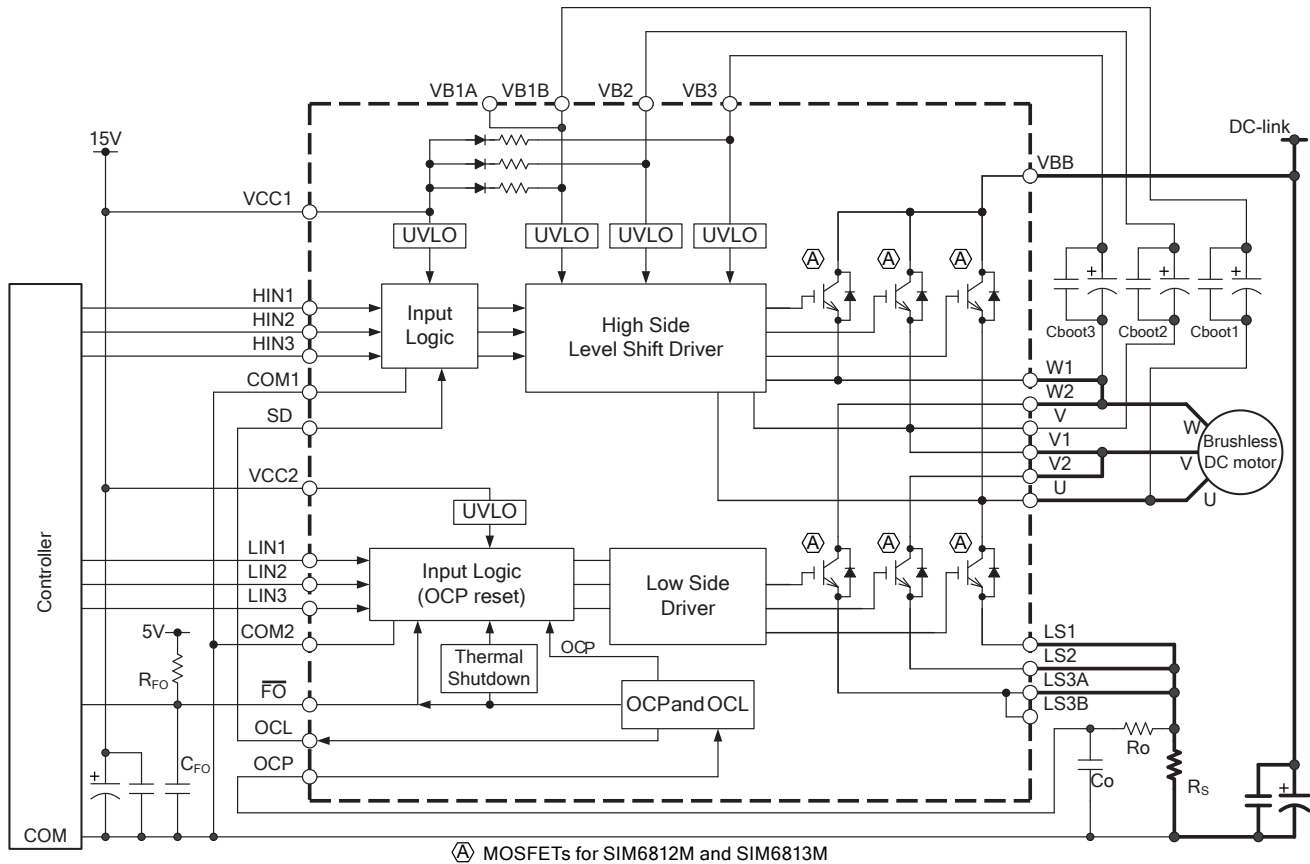

NOTE:

- W1 and W2, as well as V1 and V2 < must be externally connected to each other.
- If not using the Current Limiter (OCL) function, leave the OCL and SD pins open, but the SD pin should be connected to GND if significant external noise is observed.
- Place a pull-up resistor, R_{FO} , between the 3.3 V or 5 V supply and the IC, selected according to anti-noise characteristics, even though a 1 M Ω pull-up resistor is built-in at the \overline{FO} pin. Note that connecting to the 3.3 V or 5 V supply without a pull-up resistor disables the TSD function (however, low-side UVLO protection and OCP function remain active).
- To avoid malfunctions resulting from noise interference, place a 0.001 to 0.01 μF ceramic capacitor (C_{FO}) between the \overline{FO} and COM2 pins.
- To avoid malfunctions resulting from noise interference, the traces must be as short as possible between the IC and the bootstrap capacitors, C_{bootx} (approximately 1 μF).
- To avoid malfunctions resulting from noise interference, place a 0.01 to 0.1 μF ceramic capacitor between the VCC1 and COM1 pins, as well as between the VCC2 and COM2 pins. Also, the traces between them must be as short as possible.
- To avoid malfunctions resulting from noise interference, the traces between the current sense resistor R_S , which is placed between the LS and COM2 pins, and the IC must be as short and wide as possible.
- To avoid malfunction, the wiring between the LS and COM2 pins should be as short as possible. When wiring cannot be shortened sufficiently, insert a fast diode between LS and COM2.
- When the low pass filter (RC filter, R_O , C_O in the typical application circuit) is connected to the shunt resistor for current detection, the time constant should be set to be 0.2 μs or shorter. Care should be taken because destruction of the IPM may be caused due to detection delay when the time constant of filter is set to be 0.2 μs or longer, because a filter (1.5 $\mu\text{s}(\text{min})$) is incorporated in the OCP circuit of the IPM.

ELECTRICAL CHARACTERISTICS, valid at $T_A=25^\circ\text{C}$, unless otherwise noted

Characteristics	Symbol	Conditions	Min	Typ	Max	Units	
Logic Supply Current	I_{CC}	$V_{CC} = 15\text{ V}$	–	3.2	4.5	mA	
Bootstrap Supply Current	I_{BX}	$V_{BX} = 15\text{ V}$, $V_{HIN} = 5\text{ V}$ per phase	–	140	400	μA	
Input Voltage	V_{IH}	$V_{CC} = 15\text{ V}$, output on	–	2	2.5	V	
	V_{IL}	$V_{CC} = 15\text{ V}$, output off	1	1.5	–	V	
$\overline{\text{FO}}$ Pin Input Threshold Voltage	V_{FOIH}	$V_{CC} = 15\text{ V}$, output on	–	2	2.5	V	
	V_{FOIL}	$V_{CC} = 15\text{ V}$, output off	1	1.5	–	V	
Input Current	I_{IH}	$V_{CC} = 15\text{ V}$, $V_{IN} = 5\text{ V}$	–	230	500	μA	
	I_{IL}	$V_{IN} = 0\text{ V}$	–	–	2	μA	
Undervoltage Lock Out	V_{UVHL}	High side, between V_{Bx} and U, V, or W	9.0	10.0	11.0	V	
	V_{UVHH}		9.5	10.5	11.5	V	
	V_{UVLL}	Low side, between V_{CC} and COM	10.0	11.0	12.0	V	
	V_{UVLH}		10.5	11.5	12.5	V	
$\overline{\text{FO}}$ Pin Output Voltage	$V_{FO(L)}$	$V_{CC} = 15\text{ V}$, $V_{FO} = 5\text{ V}$, $R_{FO} = 10\text{ k}\Omega$	0	–	0.5	V	
	$V_{FO(H)}$		4.8	–	–	V	
OCL Pin Output Voltage	$V_{OCL(L)}$	$V_{CC} = 15\text{ V}$	0	–	0.5	V	
	$V_{OCL(H)}$		4.5	–	5.5	V	
Overcurrent Limit Reference Voltage	V_{LIM}	$V_{CC} = 15\text{ V}$	0.6175	0.65	0.6825	V	
Overcurrent Protection Trip Voltage	V_{TRIP}	$V_{CC} = 15\text{ V}$	0.9	1.0	1.1	V	
Overcurrent Protection Hold Time	t_p	$V_{CC} = 15\text{ V}$	20	25	–	μs	
OCP Blanking Time	$t_{bk(OCP)}$	$V_{CC} = 15\text{ V}$	–	2	–	μs	
OCL Blanking Time	$t_{bk(OCL)}$	$V_{CC} = 15\text{ V}$	–	2	–	μs	
Overtemperature Detection Threshold Temperature (Activation and Deactivation)	T_{DH}	$V_{CC} = 15\text{ V}$, no heatsink	135	150	165	$^\circ\text{C}$	
	T_{DL}		105	120	135	$^\circ\text{C}$	
Bootstrap Diode Leakage Current	I_{LBD}	$V_R = 500\text{ V}$	–	–	10	μA	
Bootstrap Diode Forward Voltage	V_{FBD}	$I_F = 0.15\text{ A}$	–	1.0	1.3	V	
Bootstrap Diode Series Resistor	R_{BD}		45	60	75	Ω	
SIM6812M and SIM6813M Switching Characteristics							
MOSFET Leakage Current	I_{DSS}	$V_{DS} = 500\text{ V}$	–	–	100	μA	
MOSFET On-State Resistance	$R_{DS(ON)}$	SIM6812M	$V_{CC} = 15\text{ V}$, $I_D = 1.25\text{ A}$, $V_{IN} = 5\text{ V}$	–	2	2.4	Ω
		SIM6813M	$V_{CC} = 15\text{ V}$, $I_D = 1.5\text{ A}$, $V_{IN} = 5\text{ V}$	–	1.4	1.7	Ω
Diode Forward Voltage	V_{SD}	SIM6812M	$V_{CC} = 15\text{ V}$, $I_D = 1.25\text{ A}$, $V_{IN} = 0\text{ V}$	–	1.0	1.5	V
		SIM6813M	$V_{CC} = 15\text{ V}$, $I_D = 1.5\text{ A}$, $V_{IN} = 0\text{ V}$	–	1.0	1.5	V
SIM6822M and SIM6827M Switching Characteristics							
IGBT Leakage Current	I_{CES}	$V_{CC} = 15\text{ V}$, $V_{CE} = 600\text{ V}$, $V_{IN} = 0\text{ V}$	–	–	1	mA	
IGBT Saturation Voltage	$V_{CE(sat)}$	$V_{CC} = 15\text{ V}$, $I_C = 5\text{ A}$, $V_{IN} = 5\text{ V}$	–	1.75	2.2	V	
Diode Forward Voltage	V_F	$V_{CC} = 15\text{ V}$, $I_{SD} = 5\text{ A}$, $V_{IN} = 0\text{ V}$	–	2.0	2.4	V	

SIM6812M SWITCHING CHARACTERISTICS, valid at $T_A=25^{\circ}\text{C}$, unless otherwise noted

Characteristics	Symbol	Conditions	Min	Typ	Max	Units
Switching Time, High Side	$t_{dH(on)}$	$V_{BB} = 300\text{ V}, V_{CC} = 15\text{ V}, I_D = 1.25\text{ A}, 0\text{ V} \leq V_{HIN} \leq 5\text{ V}$	–	910	–	ns
	t_{rH}		–	100	–	ns
	t_{rrH}		–	140	–	ns
	$t_{dH(off)}$		–	700	–	ns
	t_{fH}		–	40	–	ns
Switching Time, Low Side	$t_{dL(on)}$	$V_{BB} = 300\text{ V}, V_{CC} = 15\text{ V}, I_D = 1.25\text{ A}, 0\text{ V} \leq V_{LIN} \leq 5\text{ V}$	–	875	–	ns
	t_{rL}		–	110	–	ns
	t_{rrL}		–	155	–	ns
	$t_{dL(off)}$		–	775	–	ns
	t_{fL}		–	35	–	ns

SIM6813M SWITCHING CHARACTERISTICS, valid at $T_A=25^{\circ}\text{C}$, unless otherwise noted

Characteristics	Symbol	Conditions	Min	Typ	Max	Units
Switching Time, High Side	$t_{dH(on)}$	$V_{BB} = 300\text{ V}, V_{CC} = 15\text{ V}, I_D = 1.5\text{ A}, 0\text{ V} \leq V_{HIN} \leq 5\text{ V}$	–	820	–	ns
	t_{rH}		–	100	–	ns
	t_{rrH}		–	170	–	ns
	$t_{dH(off)}$		–	810	–	ns
	t_{fH}		–	50	–	ns
Switching Time, Low Side	$t_{dL(on)}$	$V_{BB} = 300\text{ V}, V_{CC} = 15\text{ V}, I_D = 1.5\text{ A}, 0\text{ V} \leq V_{LIN} \leq 5\text{ V}$	–	760	–	ns
	t_{rL}		–	130	–	ns
	t_{rrL}		–	180	–	ns
	$t_{dL(off)}$		–	750	–	ns
	t_{fL}		–	50	–	ns

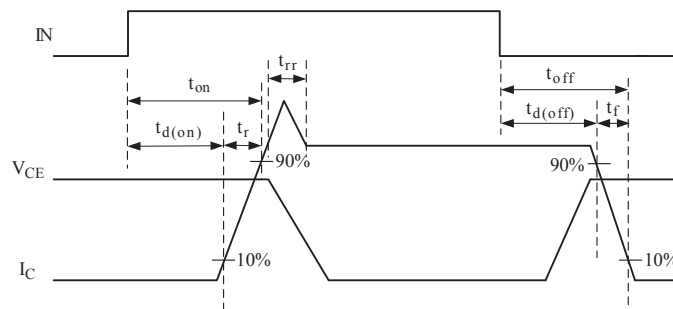

Switching Time Definition

SIM6822M SWITCHING CHARACTERISTICS, valid at $T_A=25^\circ\text{C}$, unless otherwise noted

Characteristics	Symbol	Conditions	Min	Typ	Max	Units
Switching Time, High Side	$t_{dH(on)}$	$V_{BB} = 300\text{ V}, V_{CC} = 15\text{ V}, I_C = 5\text{ A}, 0\text{ V} \leq V_{HIN} \leq 5\text{ V}$, inductive load	–	735	–	ns
	t_{rH}		–	70	–	ns
	t_{rrH}		–	80	–	ns
	$t_{dH(off)}$		–	570	–	ns
	t_{fH}		–	95	–	ns
Switching Time, Low Side	$t_{dL(on)}$	$V_{BB} = 300\text{ V}, V_{CC} = 15\text{ V}, I_C = 5\text{ A}, 0\text{ V} \leq V_{LIN} \leq 5\text{ V}$, inductive load	–	685	–	ns
	t_{rL}		–	95	–	ns
	t_{rrL}		–	80	–	ns
	$t_{dL(off)}$		–	540	–	ns
	t_{fL}		–	95	–	ns

SIM6827M SWITCHING CHARACTERISTICS, valid at $T_A=25^\circ\text{C}$, unless otherwise noted

Characteristics	Symbol	Conditions	Min	Typ	Max	Units
Switching Time, High Side	$t_{dH(on)}$	$V_{BB} = 300\text{ V}, V_{CC} = 15\text{ V}, I_C = 5\text{ A}, 0\text{ V} \leq V_{HIN} \leq 5\text{ V}$, inductive load	–	1030	–	ns
	t_{rH}		–	180	–	ns
	t_{rrH}		–	100	–	ns
	$t_{dH(off)}$		–	590	–	ns
	t_{fH}		–	150	–	ns
Switching Time, Low Side	$t_{dL(on)}$	$V_{BB} = 300\text{ V}, V_{CC} = 15\text{ V}, I_C = 5\text{ A}, 0\text{ V} \leq V_{LIN} \leq 5\text{ V}$, inductive load	–	1030	–	ns
	t_{rL}		–	240	–	ns
	t_{rrL}		–	100	–	ns
	$t_{dL(off)}$		–	540	–	ns
	t_{fL}		–	150	–	ns

Truth Table

Mode	Hin	Lin	H-side MOSFET	L-side MOSFET
Normal	L	L	Off	Off
	H	L	On	Off
	L	H	Off	On
	H	H	On	On
TSD	L	L	Off	Off
	H	L	On	Off
	L	H	Off	Off
	H	H	On	Off
OCP	L	L	Off	Off
	H	L	On	Off
	L	H	Off	Off
	H	H	On	Off
OCL ¹ Shown = L for SIM682xM (= H for SIM681xM)	L (H)	L (H)	Off	Off
	H (L)	L (H)	Off	Off
	L (H)	H (L)	Off	On
	H (L)	H (L)	Off	On
UVLO (VCC) ²	L	L	Off	Off
	H	L	Off	Off
	L	H	Off	Off
	H	H	Off	Off
UVLO (VB) ³	L	L	Off	Off
	H	L	Off	Off
	L	H	Off	On
	H	H	Off	On
\overline{FO} (= L)	L	L	Off	Off
	H	L	On	Off
	L	H	Off	Off
	H	H	On	Off

¹The OCL feature is enabled when the OCL and SD pins are tied together externally. If these pins are not tied when an OCL condition occurs, device operation continues in Normal mode.

²Returning to the Normal mode of operation from a V_{CC} UVLO condition, a high-side MOSFET resumes switching on the rising edge of an HINx input. On the other hand, a low-side MOSFET resumes switching on the first logic high of a LINx input after release of the UVLO condition.

³Returning to the Normal mode of operation from a V_B UVLO condition, a high-side MOSFET resumes switching on the rising edge of an HINx input.

Note: To prevent a shoot-through condition, the external microcontroller should not drive HINx = LINx = H at the same time.

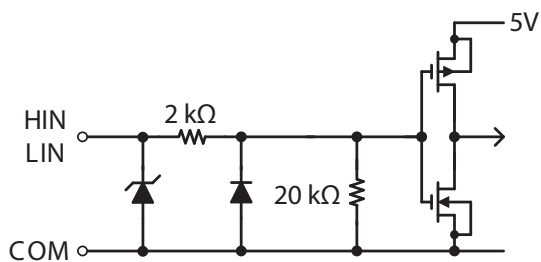

Internal equivalent circuit diagram (HIN, LIN)

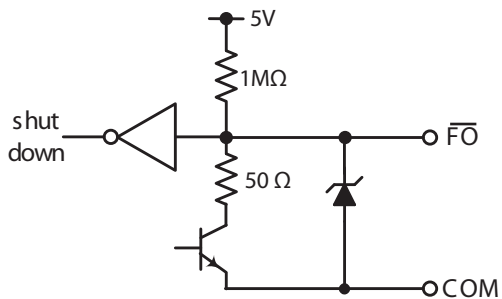

Internal equivalent circuit diagram (\overline{FO})

OCP Timing Diagram

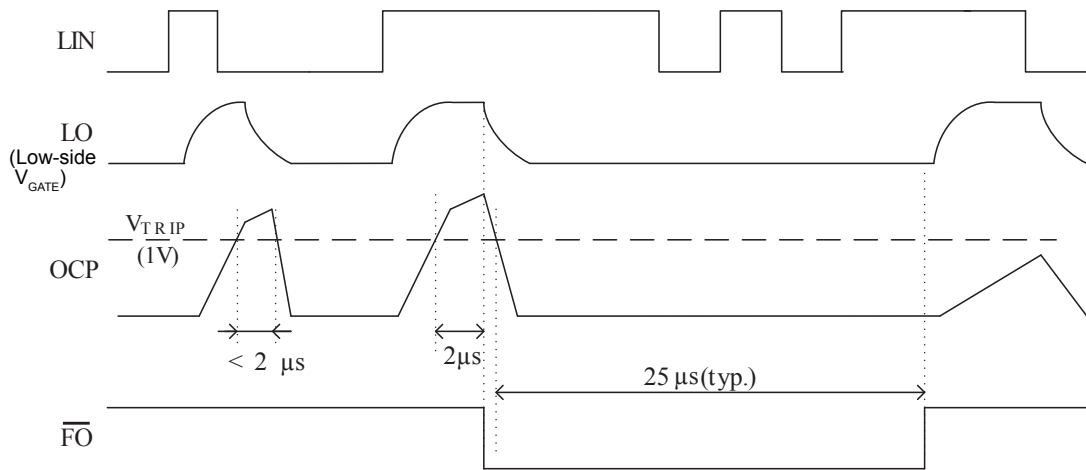

Low-Side TSD Timing Diagram

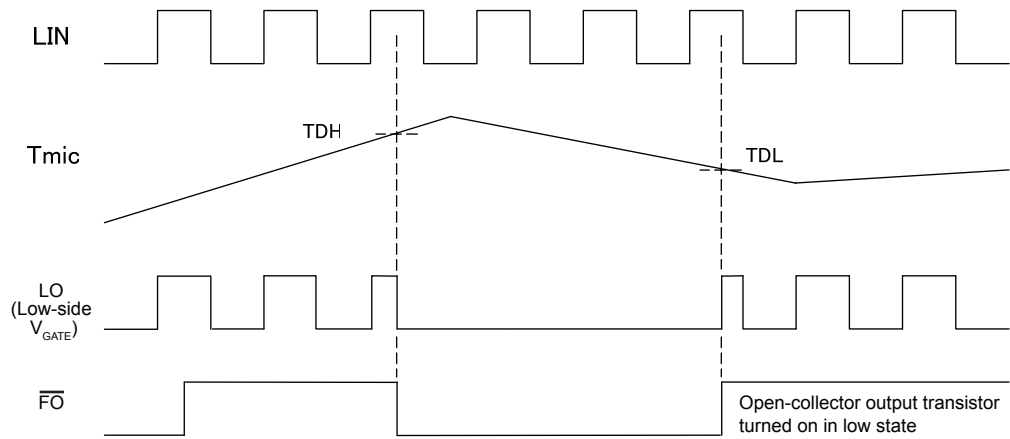

High-Side UVLO Timing Diagram

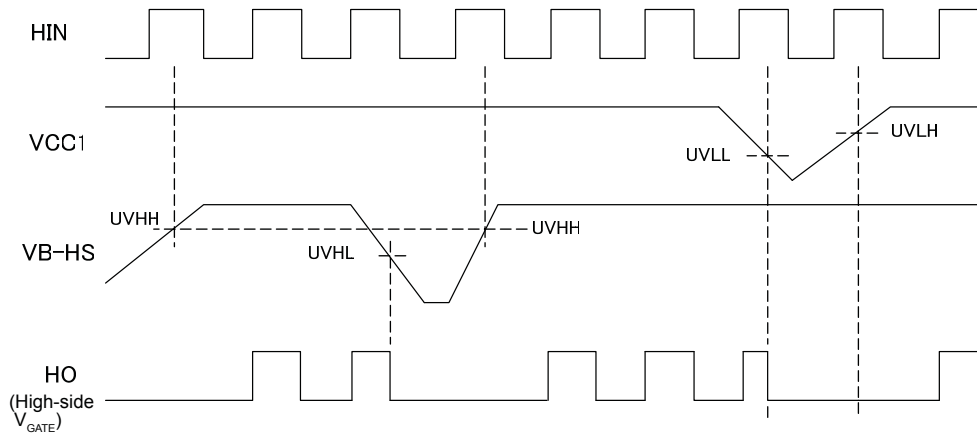

Low-Side UVLO Timing Diagram

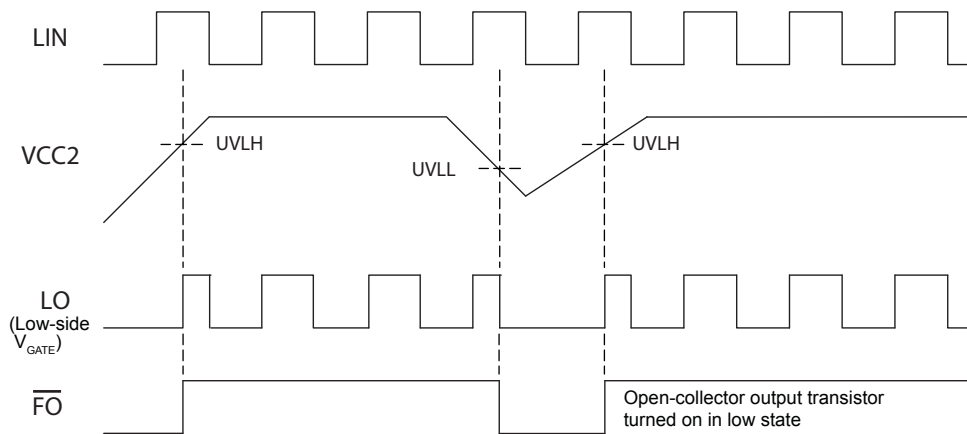

OCL Timing Diagram

(OCL and SD pins connected externally)

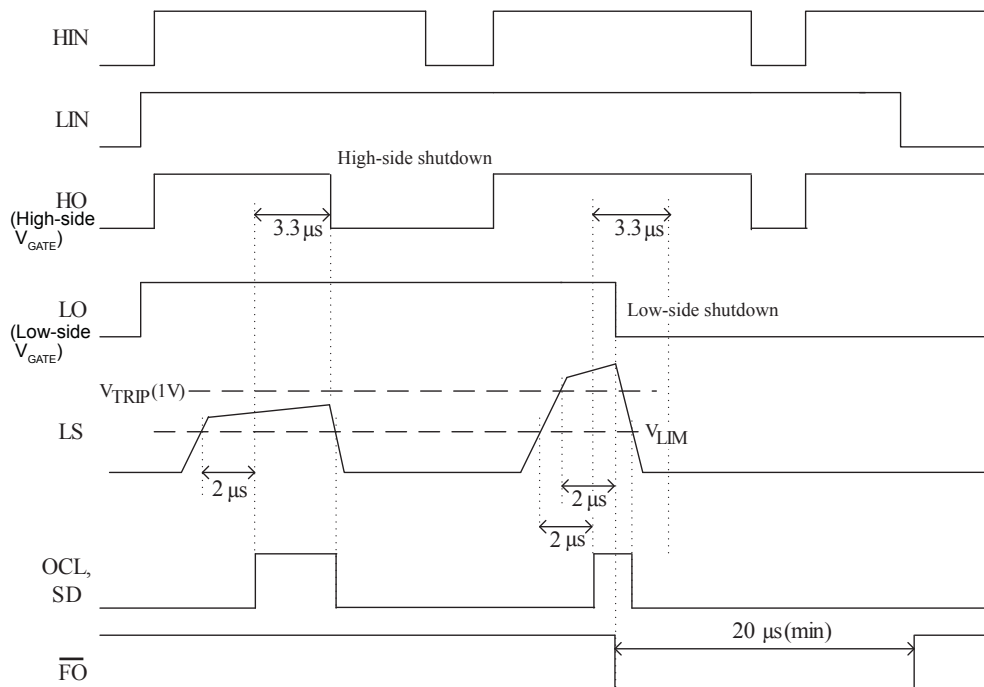

Pin-out Diagram

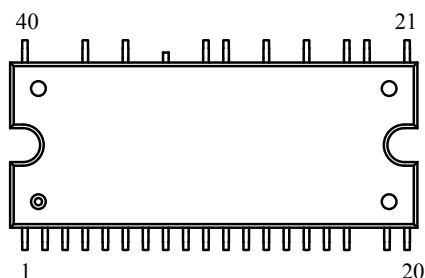

Pin List Table

Number	Name	Function	Number	Name	Function
1	LS3A	Source pin (W phase)	18,22,25, 27,29,32, 34,36, 38,39	NC	No connection (pin deleted)
2	LS2	Source pin (V phase) (optionally use pin 33)			
3	OCP	Input for Overcurrent Protection			
4	\overline{FO}	Error signal output pin			
5	VCC2	Low-side logic supply voltage			
6	COM2	Low-side logic GND pin	19	V	High side boot-strap negative pin (V phase)
7	LIN1	Low side input pin (U phase)	20	VB2	High side boot-strap positive pin (V phase)
8	LIN2	Low side input pin (V phase)	21	VB1A	High side boot-strap positive pin (U phase)
9	LIN3	Low side input pin (W phase)	22	VB3	High side boot-strap positive pin (W phase)
10	OCL	Current limiter output signal pin	24	W1	Output of W phase; connect to W2 externally
11	LS1	Source pin (U phase)	26	V1	Output of V phase; connect to V2 externally
12	SD	High-side shutdown pin	28	VBB	Main supply voltage
13	HIN1	High-side input pin (U phase)	30	VB1B	High side boot-strap positive pin (U phase)
14	HIN2	High-side input pin (V phase)	31	U	Output of U phase
15	HIN3	High-side input pin (W phase)	33	LS2	Source pin (V phase); pin trimmed
16	COM1	High-side logic GND pin	35	V2	Output of V-phase; connect to V1 externally
17	VCC1	High-side logic supply voltage	37	W2	Output of W-phase; connect to W1 externally
			40	LS3B	Source pin (W phase)

Package Diagram
SIM package

Leadform 2971

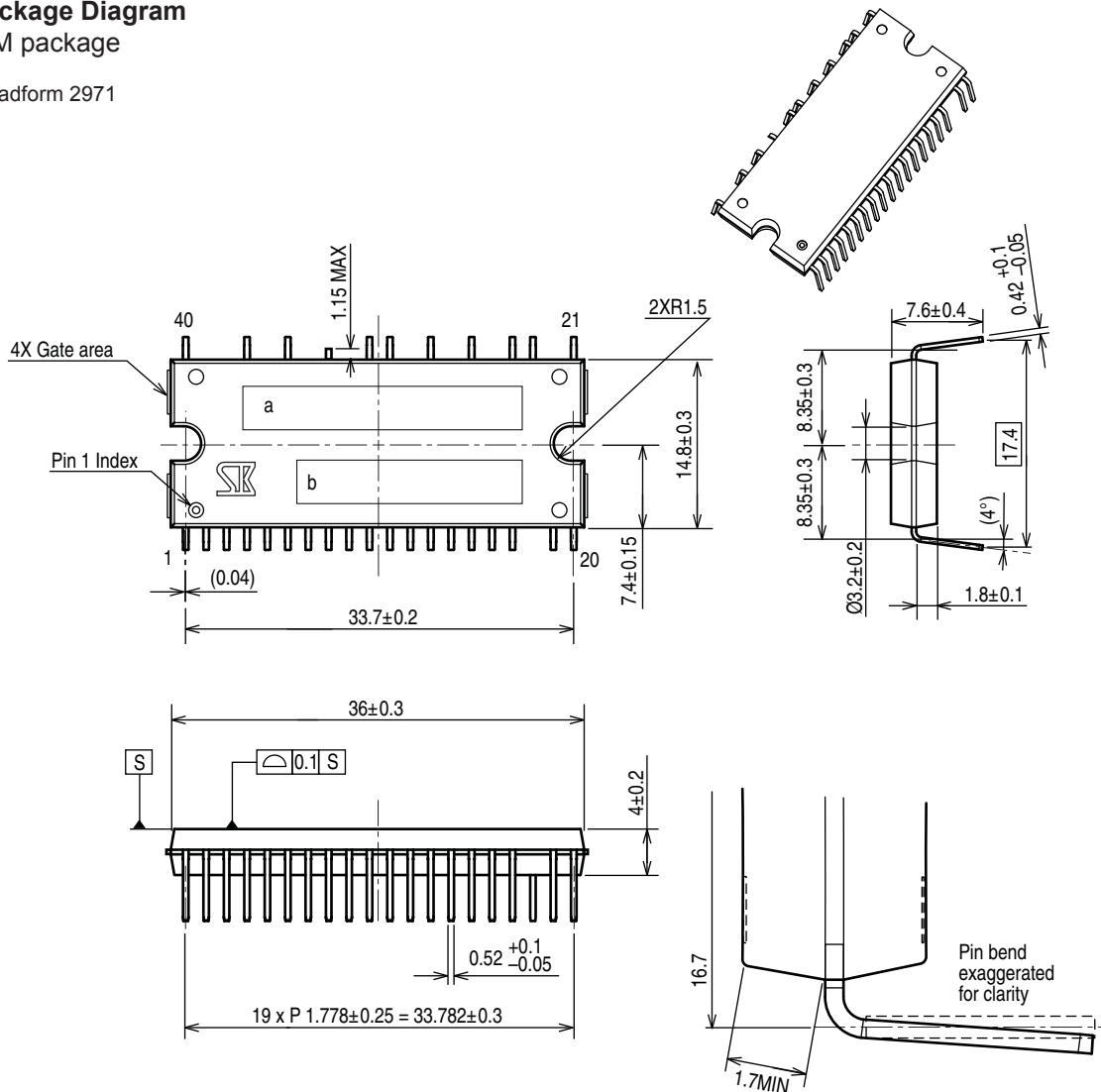

Unit: mm
Leadframe Material: Cu
Pin treatment: Solder Plating

a: Part #: SIM68xxM
b: Lot number 5 digits
1st letter: Last digit of year
2nd letter: Month
 Jan to September: Numeric
 October: O
 November: N
 December: D
3rd and 4th letter: Day
 01 to 31
5th letter: Reference number



Pb-free. Device composition compliant with the RoHS directive.

Because reliability can be affected adversely by improper storage environments and handling methods, please observe the following cautions.

Cautions for Storage

- Ensure that storage conditions comply with the standard temperature (5°C to 35°C) and the standard relative humidity (around 40% to 75%); avoid storage locations that experience extreme changes in temperature or humidity.
- Avoid locations where dust or harmful gases are present and avoid direct sunlight.
- Reinspect for rust on leads and solderability of products that have been stored for a long time.

Cautions for Testing and Handling

When tests are carried out during inspection testing and other standard test periods, protect the products from power surges from the testing device, shorts between the product pins, and wrong connections.

Remarks About Using Silicone Grease with a Heatsink

- The screw torque for mounting a heatsink must be 58.8 to 78.4 N•cm (6.0 to 8.0 Kgf•cm). When mounting, there must be no foreign substance between the product and the heatsink, except for silicone grease.
- When silicone grease is used in mounting this product on a heatsink, it shall be applied evenly and thinly. If more silicone grease than required is applied, it may produce excess stress.
- Volatile-type silicone greases may crack after long periods of time, resulting in reduced heat radiation effect. Silicone grease with low consistency (hard grease) may cause cracks in the mold resin when screwing the product to a heatsink.

- Our recommended silicone greases for heat radiation purposes, which will not cause any adverse effect on the product life, are indicated below:

Type	Suppliers
G746	Shin-Etsu Chemical Co., Ltd.
YG6260	MOMENTIVE Performance Materials, Inc
SC102	Dow Corning Toray Co., Ltd.

Soldering

- When soldering the products, please be sure to minimize the working time, within the following limits:
260±5°C 10±1 s (Flow, 2 times)
380±10°C 3.5±0.5 s (Solder iron, 1 time)
- Soldering iron should be at a distance of at least 1.5 mm from the body of the products

Electrostatic Discharge

- When handling the products, the operator must be grounded. Grounded wrist straps worn should have at least 1 MΩ of resistance from the operator to ground to prevent shock hazard, and it should be placed near the operator.
- Workbenches where the products are handled should be grounded and be provided with conductive table and floor mats.
- When using measuring equipment such as a curve tracer, the equipment should be grounded.
- When soldering the products, the head of soldering irons or the solder bath must be grounded in order to prevent leak voltages generated by them from being applied to the products.
- The products should always be stored and transported in Sanken shipping containers or conductive containers, or be wrapped in aluminum foil.

Sanken reserves the right to make, from time to time, such departures from the detail specifications as may be required to permit improvements in the performance, reliability, or manufacturability of its products. Therefore, the user is cautioned to verify that the information in this publication is current before placing any order.

When using the products described herein, the applicability and suitability of such products for the intended purpose shall be reviewed at the users responsibility.

Although Sanken undertakes to enhance the quality and reliability of its products, the occurrence of failure and defect of semiconductor products at a certain rate is inevitable.

Users of Sanken products are requested to take, at their own risk, preventative measures including safety design of the equipment or systems against any possible injury, death, fires or damages to society due to device failure or malfunction.

Sanken products listed in this publication are designed and intended for use as components in general-purpose electronic equipment or apparatus (home appliances, office equipment, telecommunication equipment, measuring equipment, etc.). Their use in any application requiring radiation hardness assurance (e.g., aerospace equipment) is not supported.

When considering the use of Sanken products in applications where higher reliability is required (transportation equipment and its control systems or equipment, fire- or burglar-alarm systems, various safety devices, etc.), contact a company sales representative to discuss and obtain written confirmation of your specifications.

The use of Sanken products without the written consent of Sanken in applications where extremely high reliability is required (aerospace equipment, nuclear power-control stations, life-support systems, etc.) is strictly prohibited.

The information included herein is believed to be accurate and reliable. Application and operation examples described in this publication are given for reference only and Sanken assumes no responsibility for any infringement of industrial property rights, intellectual property rights, or any other rights of Sanken or any third party that may result from its use. The contents in this document must not be transcribed or copied without Sanken's written consent.