



Chipsmall Limited consists of a professional team with an average of over 10 year of expertise in the distribution of electronic components. Based in Hongkong, we have already established firm and mutual-benefit business relationships with customers from,Europe,America and south Asia,supplying obsolete and hard-to-find components to meet their specific needs.

With the principle of “Quality Parts,Customers Priority,Honest Operation,and Considerate Service”,our business mainly focus on the distribution of electronic components. Line cards we deal with include Microchip,ALPS,ROHM,Xilinx,Pulse,ON,Everlight and Freescale. Main products comprise IC,Modules,Potentiometer,IC Socket,Relay,Connector.Our parts cover such applications as commercial,industrial, and automotives areas.

We are looking forward to setting up business relationship with you and hope to provide you with the best service and solution. Let us make a better world for our industry!



## Contact us

Tel: +86-755-8981 8866 Fax: +86-755-8427 6832

Email & Skype: info@chipsmall.com Web: www.chipsmall.com

Address: A1208, Overseas Decoration Building, #122 Zhenhua RD., Futian, Shenzhen, China





# Dual Lock™ Reclosable Fasteners

## SJ 3767

Technical Data

March, 2001

### General Description

SJ 3767 Dual Lock™ Reclosable Fastener is a fastener having a Type 400 stem pattern. When two pieces of Dual Lock Fasteners are pressed together, the mushroom heads interlock with one another to form a secure fastening attachment. To open, simply pull apart. SJ 3767 fastener is a 1.5 in. (38 mm) square fastener with two counter-sunk holes. This allows easy attachment to many rigid substrates using pan-head screws, pop rivets, etc. The head of the screw or rivet must be recessed below the bottom of the mushroom stems to allow proper engagement of the mushroom heads. For optimum performance, SJ 3767 fastener should be mated with Type 170 or Type 250 Dual Lock products.

### Typical Physical Properties and Performance Characteristics

**Note:** The following technical information and data should be considered representative or typical only and should not be used for specification purposes.

SJ 3767 fastener is composed of polyolefin plastic and is black in color. Weight of one piece is 4 grams. Operating temperature range is -20°F to 200°F (-29°C to 93°C).

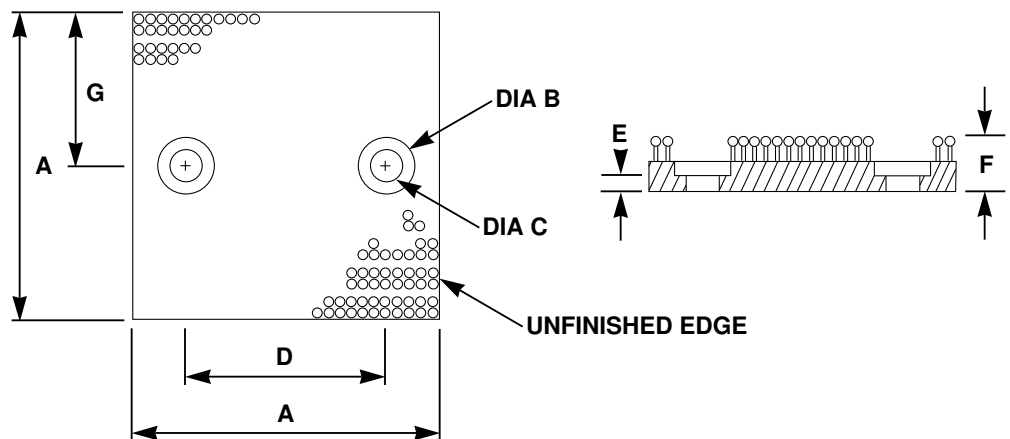

	DIM A	DIM B	DIM C	DIM D	DIM E	DIM F	DIM G
Inches:	1.50	0.30	0.14	0.98	0.06	0.20	0.75
Tolerance / Inches ±:	.030	.010	.010	.015	.020	.030	.030
Millimeters:	38.1	7.5	3.6	25.0	1.5	5.1	19.1
Tolerance / mm ±:	0.76	0.25	0.25	0.38	0.5	0.76	0.76

Nominal Engaged Thickness - Inches (mm)

	SJ 3440	SJ 3442	SJ 3540	SJ 3542	SJ 3550	SJ 3552	SJ 3767 Fastener
SJ 3767:	0.23 (5.8)	0.23 (5.8)	0.27 (6.9)	0.27 (6.9)	0.27 (6.9)	0.27 (6.9)	0.35 (9.0)

# Dual Lock™ Reclosable Fasteners

SJ 3767



## Typical Physical Properties and Performance Characteristics (continued)

**Note: The following technical information and data should be considered representative or typical only and should not be used for specification purposes.**

### Dual Lock™ products to mate with SJ 3767 fastener:

For optimum performance, SJ 3767 Type 400 Dual Lock fastener should be mated with Type 170 or Type 250 Dual Lock products. Suggested Dual Lock products to mate with SJ 3767 fastener are listed below:

	Plainbacked	General Purpose psa	VHB™ Acrylic psa
Type 170:	SJ 3442	SJ 3542	SJ 3552
Type 250:	SJ 3440	SJ 3540	SJ 3550
Typical Performance Characteristics	Type 400 mated to Type 170		Type 400 mated to Type 250

Dynamic Tensile Disengagement Strength, lbs/sq inch (kPa):		32 (221)	48 (331)
Static Tensile Holding Power, lbs/sq inch (grams/25.4 mm x 25.4 mm): (Will hold listed weight for 10,000 minutes across a temperature range of -20°F to 200°F (-29°C to 93°C))		1.1 (500)	1.1 (500)
Static Shear Holding Power, lbs/sq inch (grams/25.4 mm x 25.4 mm): (Will hold listed weight for 10,000 minutes across a temperature range of -20°F to 200°F (-29°C to 93°C))		1.1 (500)	1.1 (500)

**Note:** In long term static load applications, conditions such as temperature variation, jarring, vibration, etc. can affect long term performance. The user should design the amount of fastening area based on the specific conditions in the application. Four square inches of fastening area per pound of static load is suggested as a starting point for such evaluations.

## For Additional Information

To request additional product information or to arrange for sales assistance, call toll free 1-800-362-3550 or visit [www.3M.com/bonding](http://www.3M.com/bonding). Address correspondence to: 3M Bonding Systems Division, 3M Center, Building 220-7E-01, St. Paul, MN 55144-1000. Our fax number is 651-733-9175. In Canada, phone: 1-800-364-3577. In Puerto Rico, phone: 1-809-750-3000. In Mexico, phone: 5-728-2180.

## Important Notice

3M MAKES NO WARRANTIES, EXPRESS OR IMPLIED, INCLUDING, BUT NOT LIMITED TO, ANY IMPLIED WARRANTY OF MERCHANTABILITY OR FITNESS FOR A PARTICULAR PURPOSE. User is responsible for determining whether the 3M™ product is fit for a particular purpose and suitable for user's method of application. Please remember that many factors can affect the use and performance of a 3M Bonding System Division (BSD) product in a particular application. The materials to be bonded with the product, the surface preparation of those materials, the product selected for use, the conditions in which the product is used, and the time and environmental conditions in which the product is expected to perform are among the many factors that can affect the use and performance of a 3M BSD product. Given the variety of factors that can affect the use and performance of a 3M BSD product, some of which are uniquely within the user's knowledge and control, it is essential that the user evaluate the 3M BSD product to determine whether it is fit for a particular purpose and suitable for the user's method of application.

## Limitation of Remedies and Liability

If the 3M product is proved to be defective, THE EXCLUSIVE REMEDY, AT 3M'S OPTION, SHALL BE TO REFUND THE PURCHASE PRICE OF OR TO REPAIR OR REPLACE THE DEFECTIVE 3M PRODUCT. 3M shall not otherwise be liable for loss or damages, whether direct, indirect, special, incidental, or consequential, regardless of the legal theory asserted, including, but not limited to, contract, negligence, warranty, or strict liability.

**3M**

Bonding Systems Division  
3M Center, Building 220-7E-01  
St. Paul, MN 55144-1000



Recycled Paper  
40% pre-consumer  
10% post-consumer

Printed in U.S.A.  
©3M IPC 2001 70-0709-3873-6