



Chipsmall Limited consists of a professional team with an average of over 10 year of expertise in the distribution of electronic components. Based in Hongkong, we have already established firm and mutual-benefit business relationships with customers from,Europe,America and south Asia,supplying obsolete and hard-to-find components to meet their specific needs.

With the principle of “Quality Parts,Customers Priority,Honest Operation,and Considerate Service”,our business mainly focus on the distribution of electronic components. Line cards we deal with include Microchip,ALPS,ROHM,Xilinx,Pulse,ON,Everlight and Freescale. Main products comprise IC,Modules,Potentiometer,IC Socket,Relay,Connector.Our parts cover such applications as commercial,industrial, and automotives areas.

We are looking forward to setting up business relationship with you and hope to provide you with the best service and solution. Let us make a better world for our industry!



Contact us

Tel: +86-755-8981 8866 Fax: +86-755-8427 6832

Email & Skype: info@chipsmall.com Web: www.chipsmall.com

Address: A1208, Overseas Decoration Building, #122 Zhenhua RD., Futian, Shenzhen, China



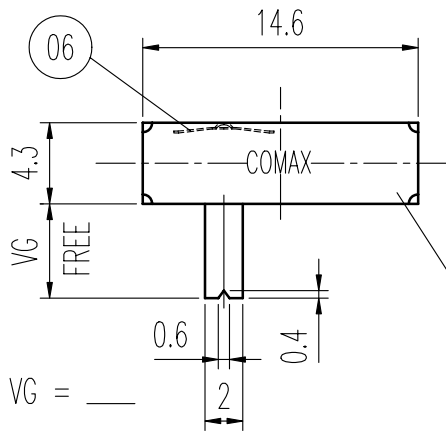

01

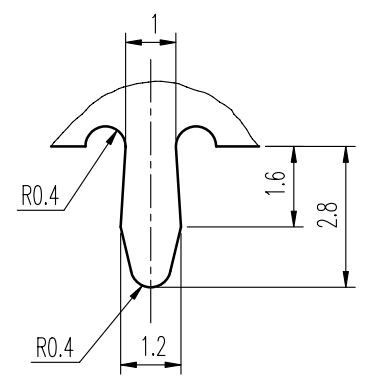

K DETAIL 3 : 1

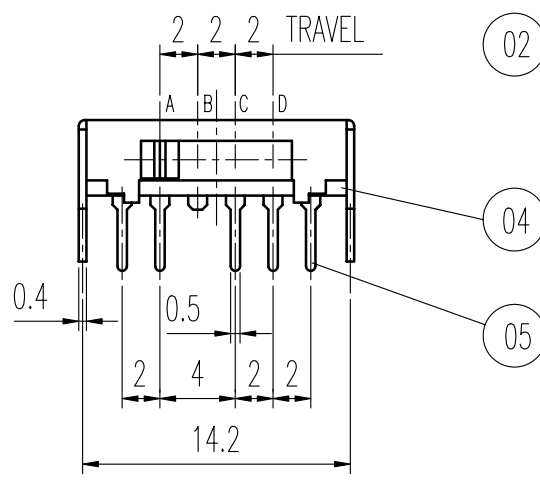

04

05

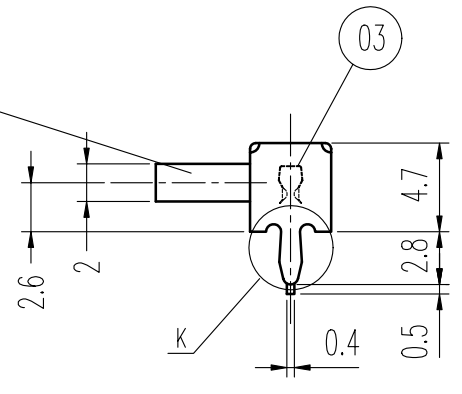

02

03



示意图 SCHEMATIC



安装孔 PIERCING PLAN

规格 Specifications

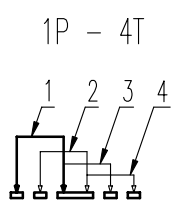
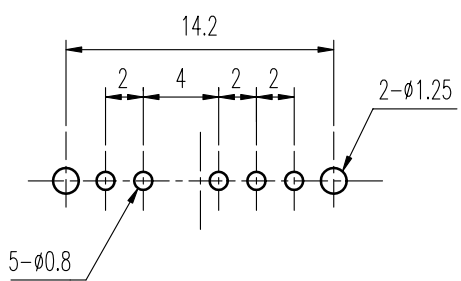
额定负荷 Ratings	DC 30 V 0.3 A
初期接触电阻 Initial Contact Resistance	30 mΩ Max.
绝缘电阻 Insulation Resistance	DC 500 V 60 Sec. 100 MΩ Min.
抗电强度 Dielectric Voltage	AC 500 V (50~60HZ) 60 Sec.
操作力 Operating Force (gf)	A→B B→C C→D
	D→C C→B B→A
负荷寿命 Operating Life With Load	10,000次 Cycles

06	弹片 SPRING PLATE	C5210R	1	NATURAL	A03	铁壳备注项由Sn PLATED变更为N PLATED, 见©	张渠江	2010-6-10
05	端子 TERMINAL	C2680R	5	Ag PLATED	A02	机械寿命 → 负荷寿命 见⑤	王光云	2006-4-24
04	基板 TERMINAL BASE	PHENOL RESIN	1	YELLOW		接触阻抗 → 初期接触电阻 见⑤		
03	接触片 CONTACT	C5210R	1	Ag CLAD	A01	C5210R/Ag → C5210R 见⑤	王光荣	2006-2-23
02	胶柄 KNOB	POM	1	VG 2 - 6	02		何锦洪	2004-12-22
01	铁壳 FRAME	SPCC	1	Ni PLATED ©	标号 REV	内容 DESCRIPTION	签名 SIGN.	日期 DATE
序NO.	零件 PART	材料 MATERIAL	数量 QTY	备注 REMARKS	DWG NO. ITEM1292			

TOLERANCES UNLESS OTHERWISE SPEC.		TITLE	SIDE KNOB SLIDE SWITCH		ITEM NO	SK-14D07-VG		
UNDER 1	± 0.10	DRAWN	张渠江	2010-6-10	VERSION	A03	PAGE	1 OF 1
1 - 10	± 0.30	REVIEWED	王光云	2010-6-10	SCALE		UNIT	mm
OVER 10	± 0.50	APPROVED	马建和	2010-6-10	PROJECTION			

COMAX 高铭电子(惠州)有限公司
Comax Electronics (Huizhou) Co., Ltd.