



Chipsmall Limited consists of a professional team with an average of over 10 year of expertise in the distribution of electronic components. Based in Hongkong, we have already established firm and mutual-benefit business relationships with customers from,Europe,America and south Asia,supplying obsolete and hard-to-find components to meet their specific needs.

With the principle of “Quality Parts,Customers Priority,Honest Operation,and Considerate Service”,our business mainly focus on the distribution of electronic components. Line cards we deal with include Microchip,ALPS,ROHM,Xilinx,Pulse,ON,Everlight and Freescale. Main products comprise IC,Modules,Potentiometer,IC Socket,Relay,Connector.Our parts cover such applications as commercial,industrial, and automotives areas.

We are looking forward to setting up business relationship with you and hope to provide you with the best service and solution. Let us make a better world for our industry!



## Contact us

Tel: +86-755-8981 8866 Fax: +86-755-8427 6832

Email & Skype: info@chipsmall.com Web: www.chipsmall.com

Address: A1208, Overseas Decoration Building, #122 Zhenhua RD., Futian, Shenzhen, China



**PRODUCT SUMMARY**

# SKY13535-11: 0.7 to 3.0 GHz DP21T (SP12T/SP9T) MIPI Main Antenna Switch for Carrier Aggregation

**Applications**

- 2G/3G/4G multimode cellular handsets (LTE, UMTS, CDMA2000, EDGE, GSM)
- Carrier aggregation (LB/HB)
- Embedded data card

**Features**

- Low band 7 insertion loss
- Integrated B17 3<sup>rd</sup> harmonic filter on low band antenna
- Excellent B17 3<sup>rd</sup> harmonic performance: -95 dBm
- Dual antenna configuration with integrated GSM low pass filters on TX ports
- Dual antenna ports can be connected externally to an LB/HB diplexer
- Integrated MIPI interface
- Small 3.6 x 2.8 x 1.0 mm 28-lead surface mount package
- Lead (Pb)-free and RoHS-compliant (MSL3 @ 260 °C per JEDEC J-STD-020)



Skyworks Green™ products are compliant with all applicable legislation and are halogen-free. For additional information, refer to *Skyworks Definition of Green™*, document number SQ04-0074.

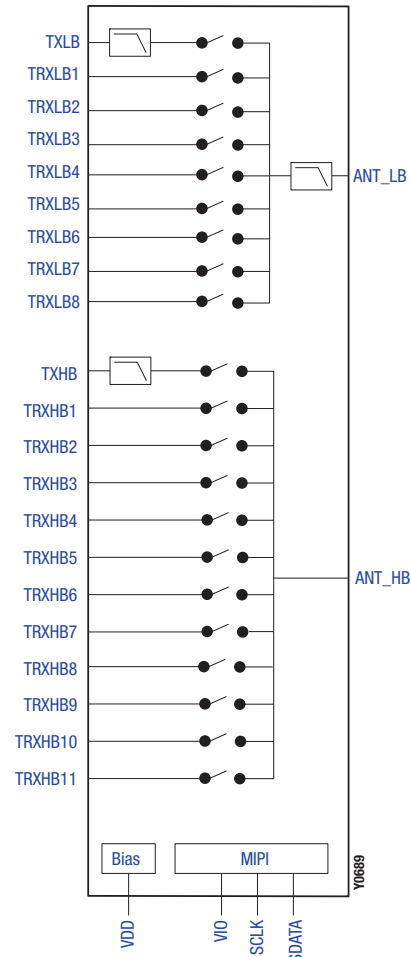

**Figure 1. SKY13535-11 Functional Block Diagram**

**Description**

The SKY13535-11 is an SP12T and SP9T with MIPI control antenna switch that is LTE-A Release 10 and Release 11 compliant. Using advanced switching technologies, the SKY13535-11 maintains low insertion loss and high isolation for both transmit and receive switching paths. The high linearity performance and low insertion loss achieved by the SKY13535-11 makes it an ideal choice for carrier aggregation applications.

The SP12T and SP9T can accommodate UMTS/C2K/EDGE/GSM/LTE applications as well as intraband carrier aggregation. There is an integrated filter in the low band side of the switch allowing all of the low band TRX ports to be used for B17. The switch also exhibits an excellent second/third order intermodulation distortion performance.

The SKY13535-11 is packaged in a small 3.6 x 2.8 x 1.0 mm 28-lead surface mount package. Switching is controlled by an integrated Mobile Industry Processor Interface (MIPI) decoder. There are separate control registers for controlling low band and high band independently. No external DC blocking capacitors are required on the RF paths as long as no DC voltage is applied. The switch can operate over the temperature range of -30°C to +90°C.

A functional block diagram of the SKY13535-11 is shown in Figure 1.

## Ordering Information

Model Name	Manufacturing Part Number	Evaluation Board Part Number
SKY13535-11: 0.7 to 3.8 GHz DP21T Switch	SKY13535-11	SKY13535-11-EVB

Copyright © 2014-2015 Skyworks Solutions, Inc. All Rights Reserved.

Information in this document is provided in connection with Skyworks Solutions, Inc. ("Skyworks") products or services. These materials, including the information contained herein, are provided by Skyworks as a service to its customers and may be used for informational purposes only by the customer. Skyworks assumes no responsibility for errors or omissions in these materials or the information contained herein. Skyworks may change its documentation, products, services, specifications or product descriptions at any time, without notice. Skyworks makes no commitment to update the materials or information and shall have no responsibility whatsoever for conflicts, incompatibilities, or other difficulties arising from any future changes.

No license, whether express, implied, by estoppel or otherwise, is granted to any intellectual property rights by this document. Skyworks assumes no liability for any materials, products or information provided hereunder, including the sale, distribution, reproduction or use of Skyworks products, information or materials, except as may be provided in Skyworks Terms and Conditions of Sale.

THE MATERIALS, PRODUCTS AND INFORMATION ARE PROVIDED "AS IS" WITHOUT WARRANTY OF ANY KIND, WHETHER EXPRESS, IMPLIED, STATUTORY, OR OTHERWISE, INCLUDING FITNESS FOR A PARTICULAR PURPOSE OR USE, MERCHANTABILITY, PERFORMANCE, QUALITY OR NON-INFRINGEMENT OF ANY INTELLECTUAL PROPERTY RIGHT; ALL SUCH WARRANTIES ARE HEREBY EXPRESSLY DISCLAIMED. SKYWORKS DOES NOT WARRANT THE ACCURACY OR COMPLETENESS OF THE INFORMATION, TEXT, GRAPHICS OR OTHER ITEMS CONTAINED WITHIN THESE MATERIALS. SKYWORKS SHALL NOT BE LIABLE FOR ANY DAMAGES, INCLUDING BUT NOT LIMITED TO ANY SPECIAL, INDIRECT, INCIDENTAL, STATUTORY, OR CONSEQUENTIAL DAMAGES, INCLUDING WITHOUT LIMITATION, LOST REVENUES OR LOST PROFITS THAT MAY RESULT FROM THE USE OF THE MATERIALS OR INFORMATION, WHETHER OR NOT THE RECIPIENT OF MATERIALS HAS BEEN ADVISED OF THE POSSIBILITY OF SUCH DAMAGE.

Skyworks products are not intended for use in medical, lifesaving or life-sustaining applications, or other equipment in which the failure of the Skyworks products could lead to personal injury, death, physical or environmental damage. Skyworks customers using or selling Skyworks products for use in such applications do so at their own risk and agree to fully indemnify Skyworks for any damages resulting from such improper use or sale.

Customers are responsible for their products and applications using Skyworks products, which may deviate from published specifications as a result of design defects, errors, or operation of products outside of published parameters or design specifications. Customers should include design and operating safeguards to minimize these and other risks. Skyworks assumes no liability for applications assistance, customer product design, or damage to any equipment resulting from the use of Skyworks products outside of stated published specifications or parameters.

Skyworks and the Skyworks symbol are trademarks or registered trademarks of Skyworks Solutions, Inc., in the United States and other countries. Third-party brands and names are for identification purposes only, and are the property of their respective owners. Additional information, including relevant terms and conditions, posted at [www.skyworksinc.com](http://www.skyworksinc.com), are incorporated by reference.