



Chipsmall Limited consists of a professional team with an average of over 10 year of expertise in the distribution of electronic components. Based in Hongkong, we have already established firm and mutual-benefit business relationships with customers from,Europe,America and south Asia,supplying obsolete and hard-to-find components to meet their specific needs.

With the principle of “Quality Parts,Customers Priority,Honest Operation,and Considerate Service”,our business mainly focus on the distribution of electronic components. Line cards we deal with include Microchip,ALPS,ROHM,Xilinx,Pulse,ON,Everlight and Freescale. Main products comprise IC,Modules,Potentiometer,IC Socket,Relay,Connector.Our parts cover such applications as commercial,industrial, and automotives areas.

We are looking forward to setting up business relationship with you and hope to provide you with the best service and solution. Let us make a better world for our industry!



## Contact us

Tel: +86-755-8981 8866 Fax: +86-755-8427 6832

Email & Skype: info@chipsmall.com Web: www.chipsmall.com

Address: A1208, Overseas Decoration Building, #122 Zhenhua RD., Futian, Shenzhen, China



DATA SHEET

# SKY66111-11: Low-Power Bluetooth® Low Energy Front-End Module for Range Extension Applications

## Applications

- Range extender
- Wearable technology
- Beacons
- Sensors
- Home automation
- Internet of Things (IoT) devices

## Features

- Low power consumption: 10 mA @ +10 dBm
- Output: +6 to +13 dBm (single-pin controllable)
- Supply operation: 1.8 to 5 V
- Low sleep current: < 1  $\mu$ A
- RX bypass
- Small MCM (20-pin, 3.3 x 3.0 x 0.8 mm) package (MSL3, 260 °C per JEDEC-J-STD-020)



Skyworks Green™ products are compliant with all applicable legislation and are halogen-free. For additional information, refer to *Skyworks Definition of Green™*, document number SQ04-0074.

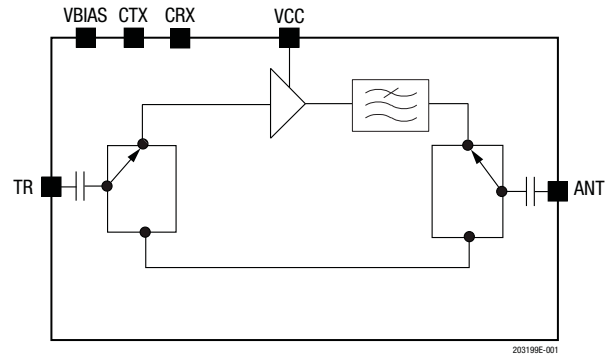

Figure 1. SKY66111-11 Functional Block Diagram

## Description

The SKY66111-11 is a highly integrated front-end module (FEM) designed for Bluetooth Low Energy (BLE) range extension applications operating in the 2.4 to 2.485 GHz range.

The device is provided in a 3.3 x 3.0 x 0.8 mm MCM package. A functional block diagram is shown in Figure 1. Pin assignments are shown in Figure 2. Signal pin assignments and functional pin descriptions are provided in Table 1.

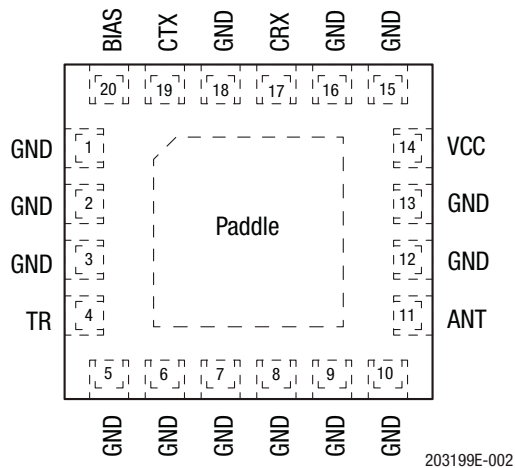

Figure 2. SKY66111-11 Pinout (Top View)

**Table 1. SKY66111-11 Signal Descriptions<sup>1</sup>**

Pin	Name	Description	Pin	Name	Description
1	GND	Ground	11	ANT	Antenna port
2	GND	Ground	12	GND	Ground
3	GND	Ground	13	GND	Ground
4	TR	Common receive/transmit port	14	VCC	Positive power supply
5	GND	Ground	15	GND	Ground
6	GND	Ground	16	GND	Ground
7	GND	Ground	17	CRX	RX control signal
8	GND	Ground	18	GND	Ground
9	GND	Ground	19	CTX	Tx control signal
10	GND	Ground	20	BIAS	PA bias current input, connect to CTX through a resistor

<sup>1</sup> The paddle should be connected to ground. See Figure 6.

## Electrical and Mechanical Specifications

The absolute maximum ratings of the SKY66111-11 are provided in Table 2. The recommended operating conditions are specified in Table 3.

Electrical specifications are provided in Tables 4 through 8.

**Table 2. SKY66111-11 Absolute Maximum Ratings<sup>1</sup>**

Parameter	Symbol	Minimum	Maximum	Units
Supply voltage	VCC		5.5	V
Control voltages	VCTX, VCRX		5.0	V
Bias voltage	VBIAS		5.0	V
RF Input power	PIN		+20	dBm
Voltage standing wave ratio	VSWR		10:1	
Operating temperature	TA	-40	+85	°C
Storage temperature	TSTG	-65	+150	°C
Electrostatic discharge: Human Body Model (HBM), Class 0	ESD		150	V

<sup>1</sup> Exposure to maximum rating conditions for extended periods may reduce device reliability. There is no damage to device with only one parameter set at the limit and all other parameters set at or below their nominal value. Exceeding any of the limits listed here may result in permanent damage to the device.

**ESD HANDLING:** *Although this device is designed to be as robust as possible, electrostatic discharge (ESD) can damage this device. This device must be protected at all times from ESD when handling or transporting. Static charges may easily produce potentials of several kilovolts on the human body or equipment, which can discharge without detection. Industry-standard ESD handling precautions should be used at all times.*

**Table 3. Recommended Operating Conditions**

Parameter	Symbol	Minimum	Typical	Maximum	Units
Frequency	f	2.4		2.485	GHz
Supply voltage	VCC	1.8	3	5.0	V
Control voltages	VCTX, VCRX	1.7	3	VCC	V
Bias voltage	VBIAS	1.25	1.8	VCC	V
Operating temperature	TA		25		°C

**Table 4. SKY66111-11 Electrical Specifications: DC Characteristics<sup>1</sup>**

(V<sub>CC</sub> = V<sub>CTX</sub> = 3.3 V, V<sub>BIAS</sub> = 1.8 V, V<sub>CRX</sub> = 0 V, T<sub>A</sub> = +25 °C, R<sub>BIAS</sub> (R1) = 0 kΩ, Characteristic Impedance [Z<sub>0</sub>] = 50 Ω, Unless Otherwise Noted)

Parameter	Symbol	Test Condition	Min	Typical	Max	Units
RX current (bypass)	ICQ_RX	RX mode		1		μA
TX quiescent current <sup>2</sup>	ICQ_TX	TX mode		6		mA
TX operating current <sup>2</sup>	IOP_TX	TX mode (P <sub>IN</sub> = -1 dBm): V <sub>CC</sub> = 1.8 V V <sub>CC</sub> = 3.0 V V <sub>CC</sub> = 3.3 V V <sub>CC</sub> = 5.0 V		8.5 10 10.5 11		mA mA mA mA
TX bias current (BIAS pin)	I <sub>BIAS_TX</sub>			550		μA
Sleep current <sup>3</sup>	ICC_OFF	Sleep mode		0.1	1	μA

<sup>1</sup> Performance is guaranteed only under the conditions listed in this table.

<sup>2</sup> For total current, I<sub>BIAS\_TX</sub> should be added to the values.

<sup>3</sup> V<sub>CTX</sub> = V<sub>BIAS</sub> = 0 V.

**Table 5. SKY66111-11 Electrical Specifications Transmit Characteristics<sup>1</sup>**

(V<sub>CC</sub> = V<sub>CTX</sub> = 3.3 V, V<sub>BIAS</sub> = 1.8 V, V<sub>CRX</sub> = 0 V, T<sub>A</sub> = +25 °C, P<sub>IN</sub> = -1 dBm, R<sub>BIAS</sub> (R1) = 0 kΩ, Characteristic Impedance [Z<sub>0</sub>] = 50 Ω, Unless Otherwise Noted)

Parameter	Symbol	Test Condition	Min	Typical	Max	Units
Output power	P <sub>OUT</sub>	V <sub>CC</sub> = 1.8 V V <sub>CC</sub> = 3.0 V V <sub>CC</sub> = 3.3 V V <sub>CC</sub> = 5.0 V		+8 +10 +10.3 +10.8		dBm dBm dBm dBm
Saturated gain <sup>2</sup>	G <sub>SAT</sub>	P <sub>IN</sub> = -1 dBm		11		dB
Gain slope	G <sub>SLOPE</sub>	Over frequency range		0.7	1	dB
Input return loss	S <sub>11</sub>			-14		dB
Output return loss	S <sub>22</sub>			-10		dB
Insertion loss (sleep mode) <sup>2</sup>	S <sub>21_SLEEP</sub>			-15	-12	dB
Third order input intercept point <sup>2</sup>	IIP3	@ 2.44 GHz, Δf = ± 1 MHz, P <sub>IN</sub> = -14 dBm/tone		+5		dBm
Third order output intercept point <sup>2</sup>	OIP3	@ 2.44 GHz, Δf = ± 1 MHz, P <sub>IN</sub> = -14 dBm/tone		+16		dBm
1 dB input compression point	IP1dB			-1		dBm
1 dB output compression point	OP1dB			+10		dBm
2 <sup>nd</sup> to 10 <sup>th</sup> harmonics <sup>2</sup>	2fo to 10fo				-30	dBm/MHz
RX to TX transition time <sup>2</sup>	t <sub>SWITCH</sub>	10% to 90% RF 50% V <sub>CTX</sub> to 90% RF		500		ns
TX power on time <sup>2</sup>	t <sub>ON</sub>	10% to 90% RF 50% V <sub>CTX</sub> to 90% RF		500		ns
TX power off time <sup>2</sup>	t <sub>OFF</sub>	90% to 10% RF 50% V <sub>CTX</sub> to 10% RF		150		ns

<sup>1</sup> Performance is guaranteed only under the conditions listed in this table.

<sup>2</sup> Guaranteed by characterization.

**Table 6. SKY66111-11 Electrical Specifications: Receive Characteristics<sup>1</sup>**  
**(V<sub>CC</sub> = 3.3 V, V<sub>CRX</sub> = 3.3 V, V<sub>CTX</sub> = 0 V, T<sub>A</sub> = +25 °C, P<sub>IN</sub> = -20 dBm, Characteristic Impedance [Z<sub>0</sub>] = 50 Ω, Unless Otherwise Noted)**

Parameter	Symbol	Test Condition	Min	Typical	Max	Units
Insertion loss	S21			0.9		dB
Isolation	S12	TX Mode (P <sub>IN</sub> = -20 dBm)		25		dB
Input return loss	S11			-15		dB
Output return loss	S22			-15		dB
TX to RX transition time <sup>2</sup>	t <sub>SWITCH</sub>	10% to 90% RF 50% V <sub>CRX</sub> to 90% RF		500		ns
RX power on time <sup>2</sup>	t <sub>ON</sub>	10% to 90% RF 50% V <sub>CRX</sub> to 90% RF		150		ns
RX power off time <sup>2</sup>	t <sub>OFF</sub>	90% to 10% RF 50% V <sub>CRX</sub> to 10% RF		150		ns

<sup>1</sup> Performance is guaranteed only under the conditions listed in this table.

<sup>2</sup> Guaranteed by characterization.

**Table 7. SKY66111-11 Electrical Characteristics: Logic Characteristics (T<sub>A</sub> = +25 °C)**

Parameter	Symbol	Minimum	Maximum	Units
Voltage logic high <sup>1</sup>	V <sub>HIGH</sub>	1.7	5	V
Voltage logic low	V <sub>LOW</sub>	0	0.2	V

<sup>1</sup> Difference between logic high voltages for V<sub>CRX</sub> and V<sub>CTX</sub> should not exceed 0.2 V.

**Table 8. SKY66111-11 Mode Logic Truth Table**

Mode	CTX	CRX	BIAS
Sleep mode	0	0	0
Receive (RX) mode	0	1	0
Transmit (TX) mode	1	0	1 <sup>1</sup>
Non-permissible state <sup>2</sup>	1	1	x

<sup>1</sup> Analog voltage control for PA output power. See Figure 3.

<sup>2</sup> This state will enable both the TX and RX paths. It is not permitted to operate in this state.

### BIAS Pin Usage

The SKY66111-11 BIAS pin supplies the bias to the internal PA. By varying the voltage at this pin, PA operating parameters including gain, supply current, and efficiency can be adjusted.

The BIAS pin can also be used to adjust the SKY66111-11 output power when the RF source (transceiver or baseband) has a fixed level.

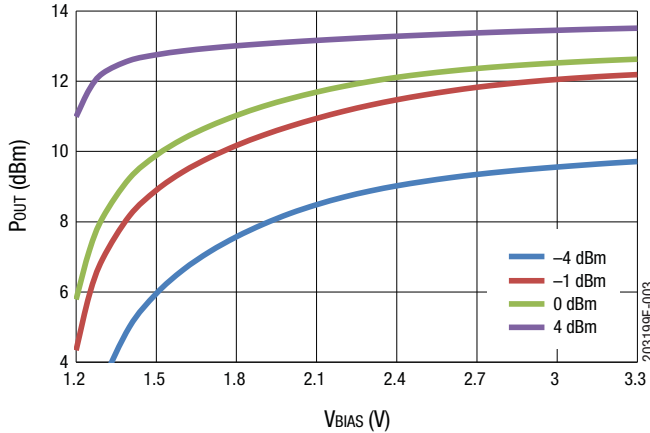

Figure 3. Pout vs VBIAS & PIN (Vcc = 3.3 V)

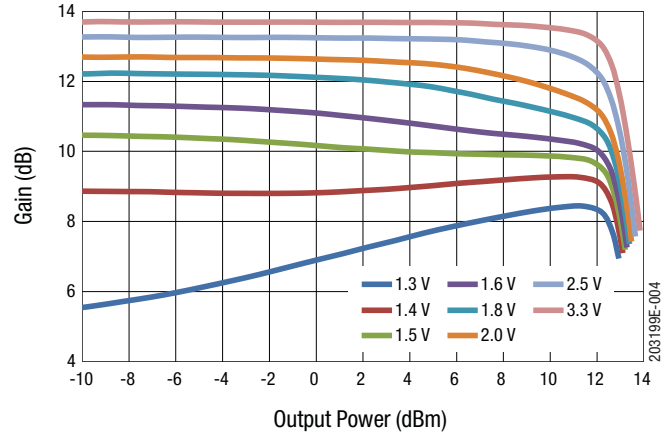

Figure 4. Gain vs Pout & VBIAS (Vcc = 3.3 V)

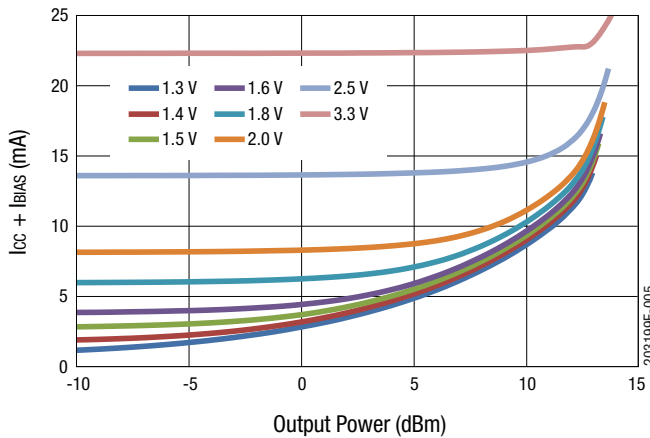

Figure 5. Icc vs Pout & VBIAS (Vcc = 3.3 V)

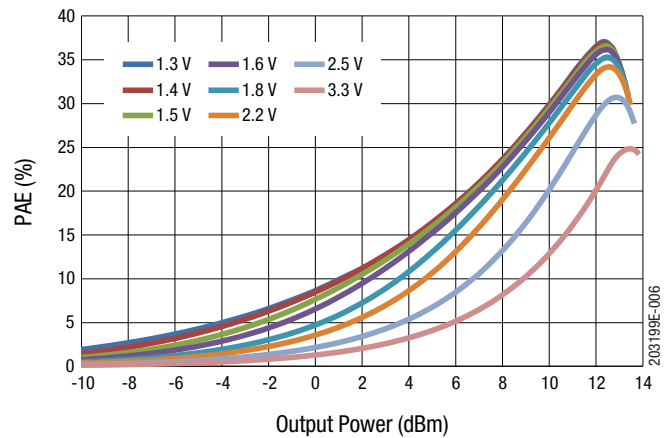

Figure 6. Power-Added Efficiency vs Pout & VBIAS (Vcc = 3.3 V)

In many applications, a variable DC supply voltage may not be available. The desired bias voltage can be generated by connecting BIAS to the GPIO controlling CTX with a resistor (refer to Figure 12). With no RF input, the BIAS pin draws approximately 10% of the main supply current. Toggling BIAS from the CTX GPIO

also causes the PA to turn off when CTX is pulled low, reducing the RX and shutdown mode current.

Table 9 lists the relationship between bias voltage/current and bias resistance.

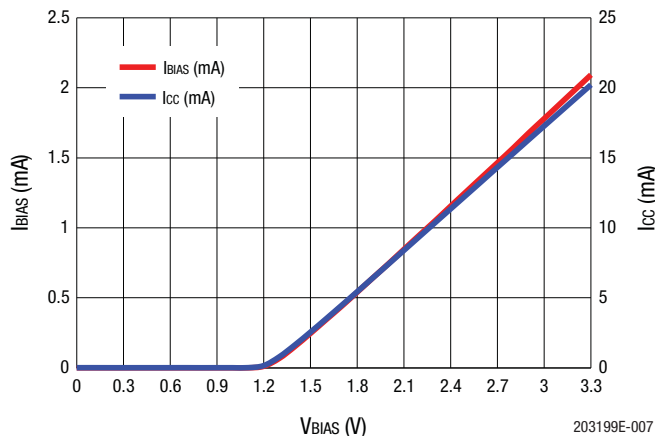

Figure 7. IBIAS and ICC vs VBIAS (VCC = 3.3 V, no RF)

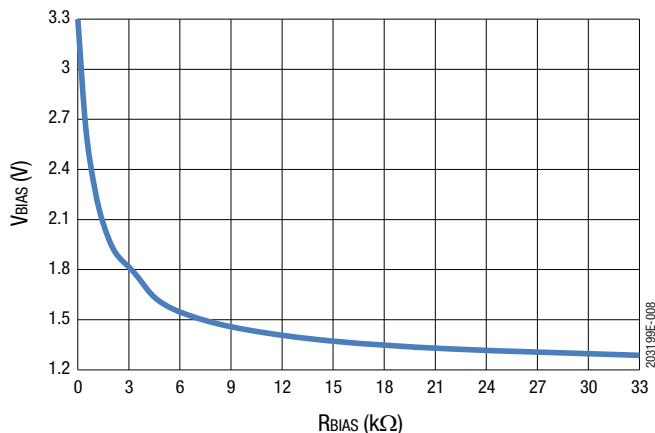

Figure 8. VBIAS vs RBIAS (VCC = 3.3 V)

Table 9. Bias Voltage and Current vs Bias Resistance (VCC = 3.3 V)

RBIAS (kΩ)	VBIAS (V)	IBIAS (mA)
0	3.30	2.09
0.47	2.65	1.41
1	2.28	1.03
1.5	2.07	0.82
2.2	1.90	0.64
3.3	1.78	0.48
4.7	1.62	0.36
6.8	1.52	0.26
10	1.44	0.19
15	1.37	0.13
22	1.32	0.09
33	1.29	0.06

If a fixed BIAS voltage (for example, from an LDO) is available in the application circuit, using this instead of a resistor reduces the variation of output power with VCC. To minimize SKY66111-11

current consumption in RX bypass and shutdown modes, the voltage to the BIAS pin should be switched off when the CTX is logic low.

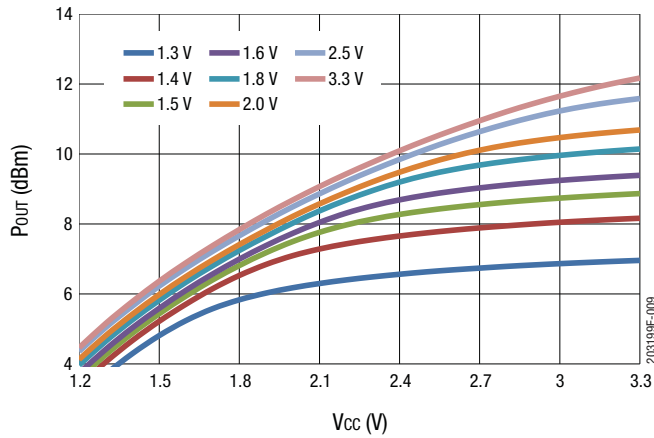

Figure 9. Pout vs Vcc & VBIAS (PIN = -1 dBm)

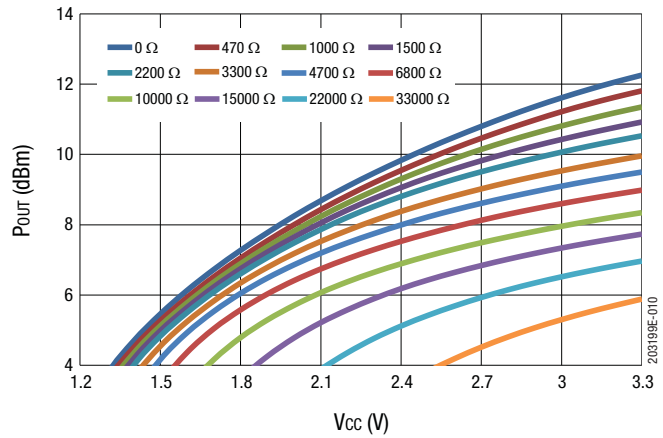

Figure 10. Pout vs Vcc & RBIAS (PIN = -1 dBm)



## Evaluation Board Description

The SKY66111-11 Evaluation Board is used to test the performance of the SKY66111-11 front-end module. The board is optimized for evaluation, experimentation, and investigation with a Bluetooth Low Energy signal source. The design and layout can be quickly and easily transferred into a production design.

An Evaluation Board schematic is provided in Figure 11. A reference design schematic is provided in Figure 12. Table 10 provides the Bill of Materials (BOM) list for Evaluation Board components. A photograph of the Evaluation Board is shown in Figure 13.

## Evaluation Board Setup Procedure

### Connect Supply

1. Connect J1 and J4 to 50  $\Omega$  instruments. Terminate all unused ports (if applicable) with 50  $\Omega$ .
2. Connect the supply ground to Pins 1, 4, and 6 of J2.
3. Connect 3.3 V to pin 7 of J2.
4. Connect 1.8 V to one of the logic pins (pin 3 or pin 5) on J2 to select RX or TX mode. For TX mode, also connect pin 2 to 1.8 V. Connect the other logic pin to ground. Refer to Table 8 for mode control settings.

### Measure Performance

#### TX

Monitor the 2.4 GHz amplifier performance by applying an RF signal to connector J4 (TR) and verify the output power on connector J1 (ANT).

#### RX

Monitor the 2.4 GHz switch performance by applying an RF signal to connector J1 (ANT) and verify the output signal on connector J4 (TR).

---

**CAUTION:** Care should be taken not to overdrive the switch by applying too much RF on the input to the device. A starting input power of  $-20$  dBm is suitable for the device.

---

## Package Dimensions

The PCB layout footprint for the SKY66111-11 is provided in Figure 14. Typical part markings are shown in Figure 15. Package dimensions are shown in Figure 16, and tape and reel dimensions are provided in Figure 17.

## Package and Handling Information

Since the device package is sensitive to moisture absorption, it is baked and vacuum packed before shipping. Instructions on the shipping container label regarding exposure to moisture after the container seal is broken must be followed. Otherwise, problems related to moisture absorption may occur when the part is subjected to high temperature during solder assembly.

The SKY66111-11 is rated to Moisture Sensitivity Level 3 (MSL3) at 260 °C. It can be used for lead or lead-free soldering. For additional information, refer to the Skyworks Application Note, *PCB Design and SMT Assembly/Rework Guidelines for MCM-L Packages*, document number 101752.

Care must be taken when attaching this product, whether it is done manually or in a production solder reflow environment. Production quantities of this product are shipped in a standard tape and reel format.

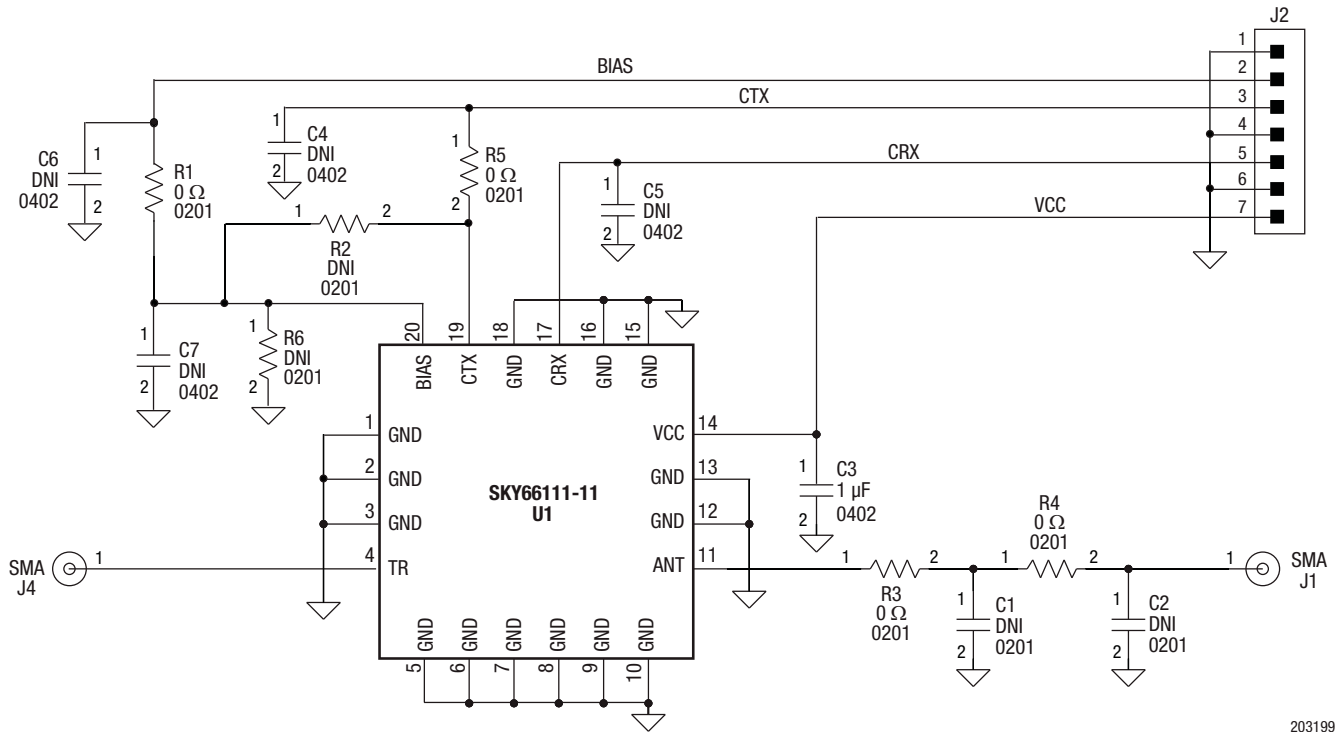

203199E-011

Figure 11. SKY66111-11 Evaluation Board Schematic

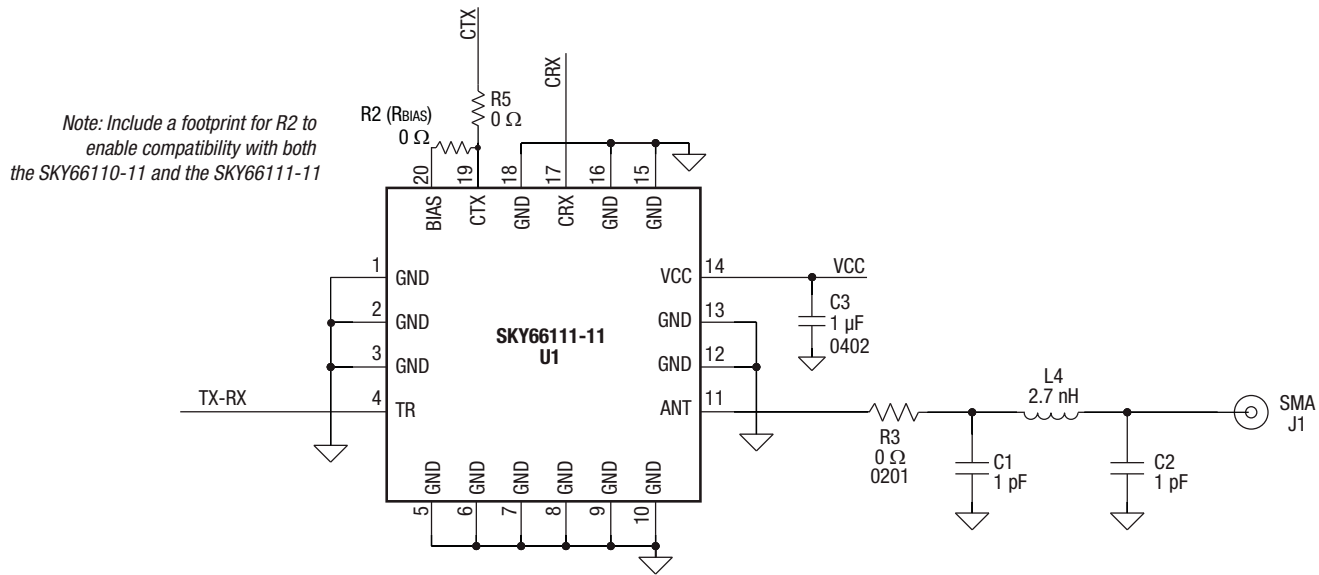

203199E-012

Figure 12. SKY66111-11 Reference Design Schematic

**Table 10. SKY66111-11 Evaluation Board Bill of Materials (BOM)**

Component	Value	Size	Manufacturer	Mfr Part Number	Characteristics
C1, C2	DNI	0201			
C3	1 $\mu$ F	0402			Capacitor
C4, C5, C6	DNI	0402			
J1, J4	SMA	end launch	Johnson Components	142-0701-851	SMA end launch straight jack receptacle - tab contact
J2	7X1	100 mil	Samtec	TSW-107-07-G-S	100 mil header
PCB1	Z720-B		Skyworks Solutions Inc.	Z720-B	PCB
R2, R6	DNI	0201			Do not install
R1 (RBIAS), R3, R4, R5	0 $\Omega$	0201	Panasonic	ERJ1GE0R00	Thick film chip resistor
U1	SKY66111-11	MCM50P300X330-20	Skyworks Solutions Inc.	SKY66111-11	Low-power Bluetooth Low Energy ranger extender

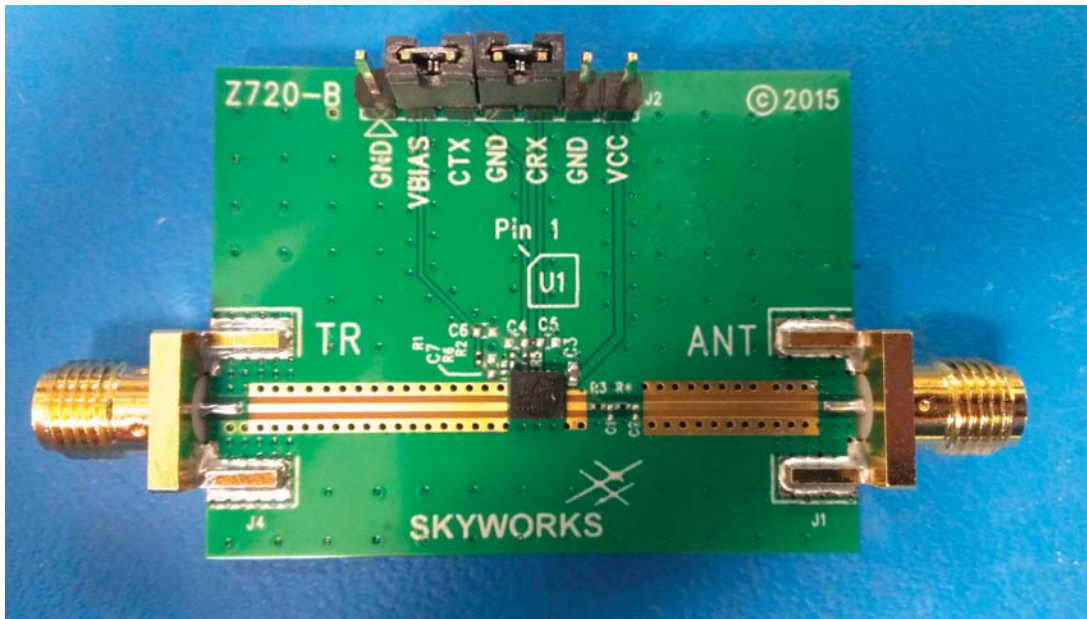

**Figure 13. SKY66111-11 Evaluation Board**

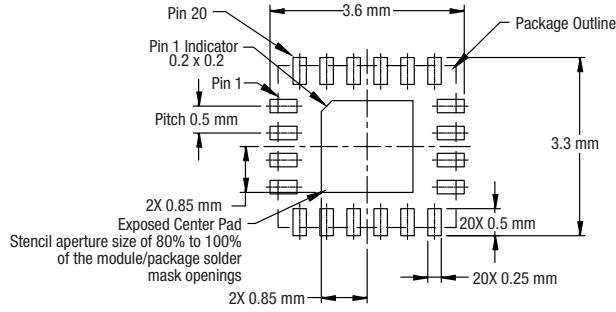

Stencil Aperture

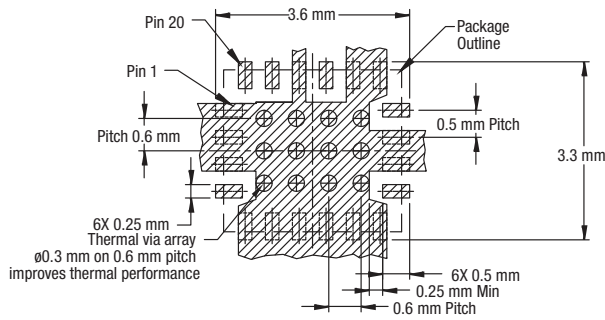

Metallization

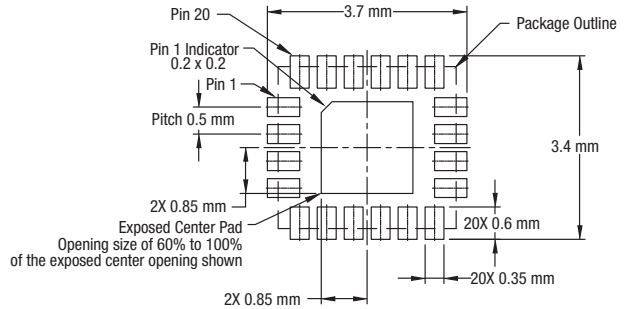

Solder Mask Opening

Notes:

1. All dimensions are in millimeters, unless otherwise specified.
2. Thermal vias should be resin filled and capped in accordance with IPC-4761 Type VII vias. Recommended Cu thickness is 30 to 35  $\mu\text{m}$ .

203199E-014

Figure 14. PCB Layout Footprint

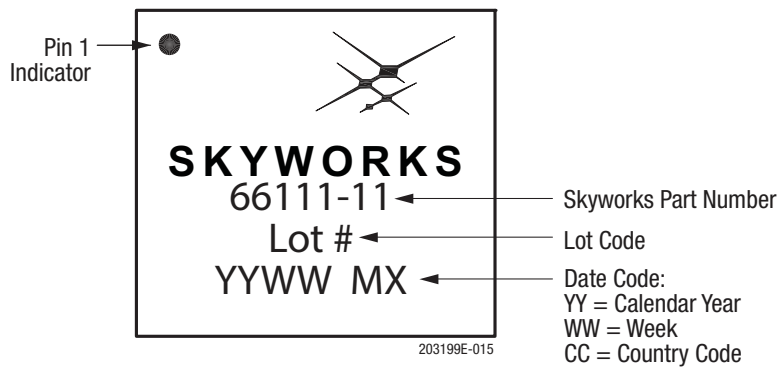
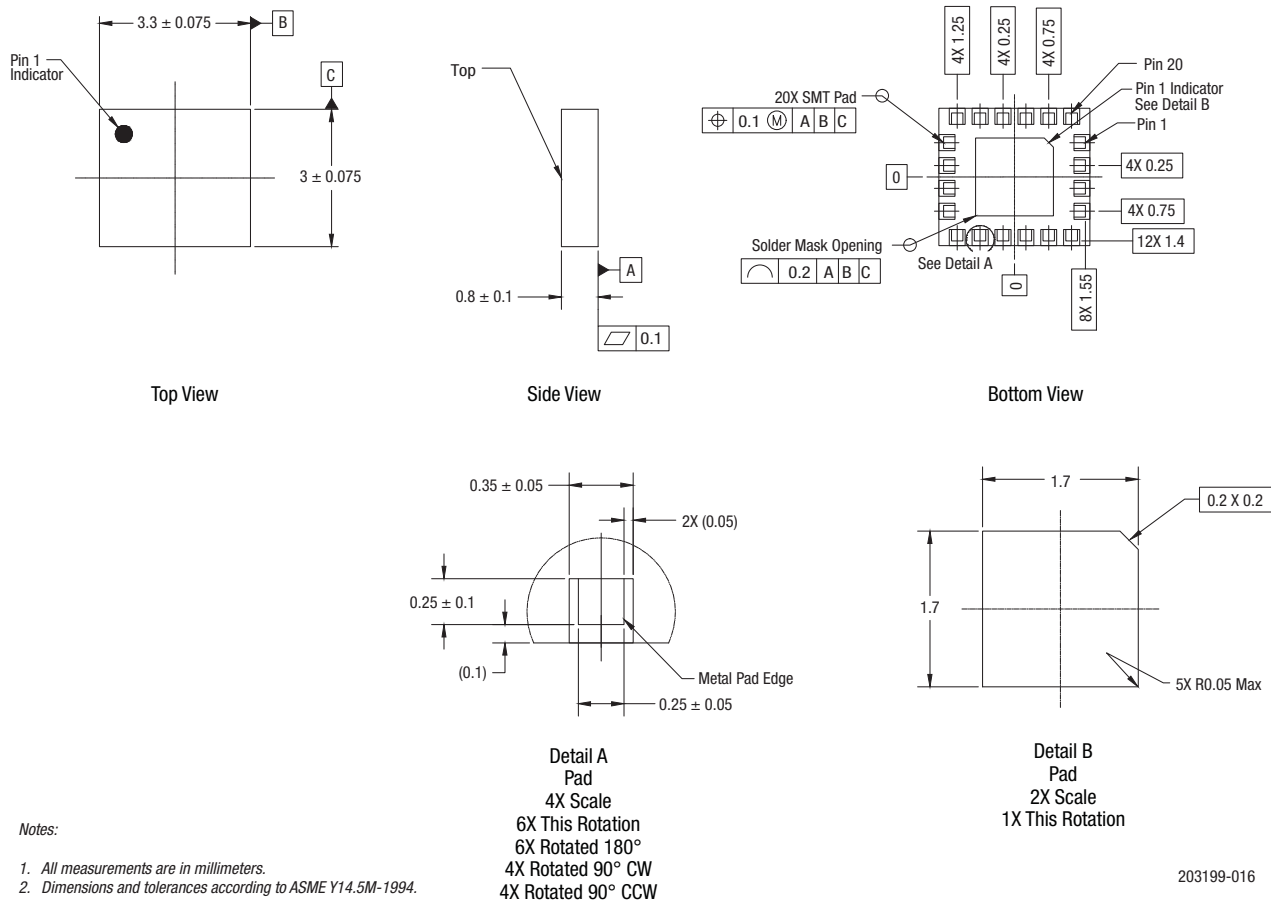
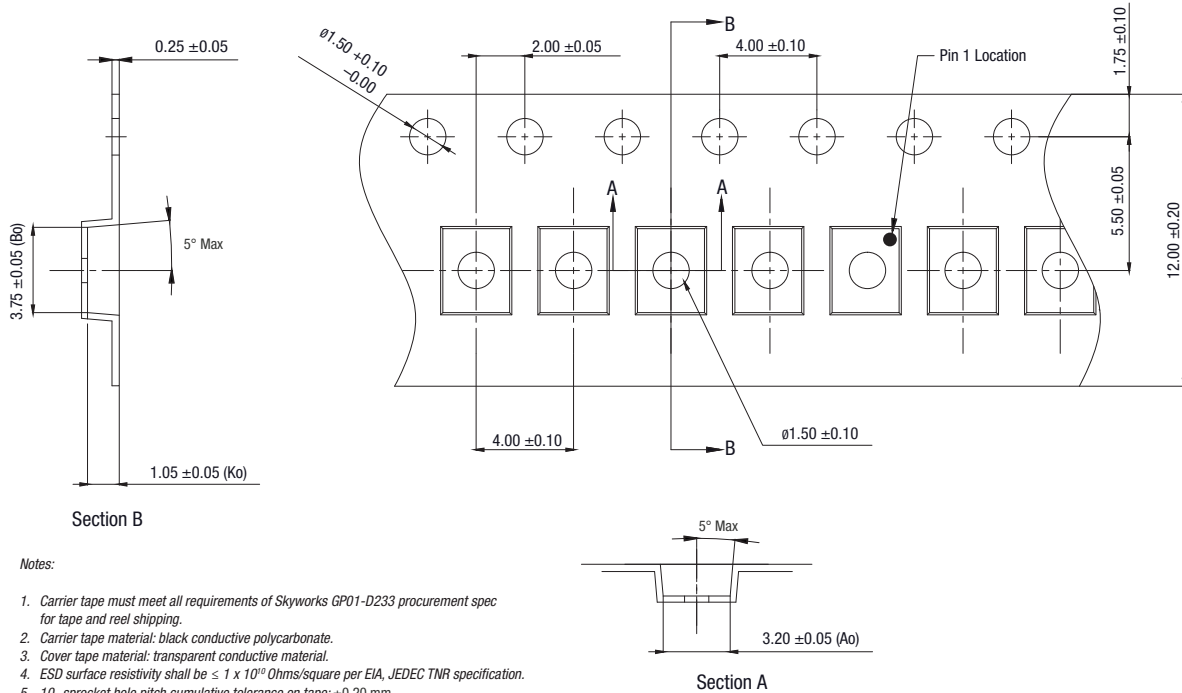

Figure 15. Typical Part Markings

**DATA SHEET • SKY66111-11: LOW-POWER BLUETOOTH LOW ENERGY FEM**



**Figure 16. SKY66111-11 Package Dimensions**



203199E-017

**Figure 17. SKY66111-11 Tape and Reel Dimensions**

## Ordering Information

Model Name	Manufacturing Part Number	Evaluation Board Part Number
SKY66111-11	SKY66111-11	SKY66111-11-EK1

Copyright © 2015-2016 Skyworks Solutions, Inc. All Rights Reserved.

Information in this document is provided in connection with Skyworks Solutions, Inc. (“Skyworks”) products or services. These materials, including the information contained herein, are provided by Skyworks as a service to its customers and may be used for informational purposes only by the customer. Skyworks assumes no responsibility for errors or omissions in these materials or the information contained herein. Skyworks may change its documentation, products, services, specifications or product descriptions at any time, without notice. Skyworks makes no commitment to update the materials or information and shall have no responsibility whatsoever for conflicts, incompatibilities, or other difficulties arising from any future changes.

No license, whether express, implied, by estoppel or otherwise, is granted to any intellectual property rights by this document. Skyworks assumes no liability for any materials, products or information provided hereunder, including the sale, distribution, reproduction or use of Skyworks products, information or materials, except as may be provided in Skyworks Terms and Conditions of Sale.

THE MATERIALS, PRODUCTS AND INFORMATION ARE PROVIDED “AS IS” WITHOUT WARRANTY OF ANY KIND, WHETHER EXPRESS, IMPLIED, STATUTORY, OR OTHERWISE, INCLUDING FITNESS FOR A PARTICULAR PURPOSE OR USE, MERCHANTABILITY, PERFORMANCE, QUALITY OR NON-INFRINGEMENT OF ANY INTELLECTUAL PROPERTY RIGHT; ALL SUCH WARRANTIES ARE HEREBY EXPRESSLY DISCLAIMED. SKYWORKS DOES NOT WARRANT THE ACCURACY OR COMPLETENESS OF THE INFORMATION, TEXT, GRAPHICS OR OTHER ITEMS CONTAINED WITHIN THESE MATERIALS. SKYWORKS SHALL NOT BE LIABLE FOR ANY DAMAGES, INCLUDING BUT NOT LIMITED TO ANY SPECIAL, INDIRECT, INCIDENTAL, STATUTORY, OR CONSEQUENTIAL DAMAGES, INCLUDING WITHOUT LIMITATION, LOST REVENUES OR LOST PROFITS THAT MAY RESULT FROM THE USE OF THE MATERIALS OR INFORMATION, WHETHER OR NOT THE RECIPIENT OF MATERIALS HAS BEEN ADVISED OF THE POSSIBILITY OF SUCH DAMAGE.

Skyworks products are not intended for use in medical, lifesaving or life-sustaining applications, or other equipment in which the failure of the Skyworks products could lead to personal injury, death, physical or environmental damage. Skyworks customers using or selling Skyworks products for use in such applications do so at their own risk and agree to fully indemnify Skyworks for any damages resulting from such improper use or sale.

Customers are responsible for their products and applications using Skyworks products, which may deviate from published specifications as a result of design defects, errors, or operation of products outside of published parameters or design specifications. Customers should include design and operating safeguards to minimize these and other risks. Skyworks assumes no liability for applications assistance, customer product design, or damage to any equipment resulting from the use of Skyworks products outside of stated published specifications or parameters.

Skyworks and the Skyworks symbol are trademarks or registered trademarks of Skyworks Solutions, Inc., in the United States and other countries. Third-party brands and names are for identification purposes only, and are the property of their respective owners. Additional information, including relevant terms and conditions, posted at [www.skyworksinc.com](http://www.skyworksinc.com), are incorporated by reference.