



Chipsmall Limited consists of a professional team with an average of over 10 year of expertise in the distribution of electronic components. Based in Hongkong, we have already established firm and mutual-benefit business relationships with customers from,Europe,America and south Asia,supplying obsolete and hard-to-find components to meet their specific needs.

With the principle of “Quality Parts,Customers Priority,Honest Operation,and Considerate Service”,our business mainly focus on the distribution of electronic components. Line cards we deal with include Microchip,ALPS,ROHM,Xilinx,Pulse,ON,Everlight and Freescale. Main products comprise IC,Modules,Potentiometer,IC Socket,Relay,Connector.Our parts cover such applications as commercial,industrial, and automotives areas.

We are looking forward to setting up business relationship with you and hope to provide you with the best service and solution. Let us make a better world for our industry!



Contact us

Tel: +86-755-8981 8866 Fax: +86-755-8427 6832

Email & Skype: info@chipsmall.com Web: www.chipsmall.com

Address: A1208, Overseas Decoration Building, #122 Zhenhua RD., Futian, Shenzhen, China



DATA SHEET

SKY85300-21: 2.4 GHz, 256 QAM WLAN/Bluetooth® Front-End Module

Applications

- WiFi-enabled smartphones, tablets, and mobile/portable devices
- System-in-Package (SIP) modules for embedded systems

Features

- Integrated high-performance 2.4 GHz PA, harmonic filter, LNA with bypass, and T/R switch
- Fully matched input and output
- LNA with integrated bypass mode
- High performance SP3T switch to support Bluetooth/WiFi functions
- Integrated positive slope power detector
- Transmit gain: 26 dB
- Receive gain: 12 dB
- Output power: +22 dBm, MCS7, 5 V
- Output power: +21 dBm, MCS9, 5 V
- Small QFN (16-pin, 3 x 3 mm) package (MSL1, 260 °C per JEDEC J-STD-020)



Skyworks Green™ products are compliant with all applicable legislation and are halogen-free. For additional information, refer to *Skyworks Definition of Green™*, document number SQ04-0074.

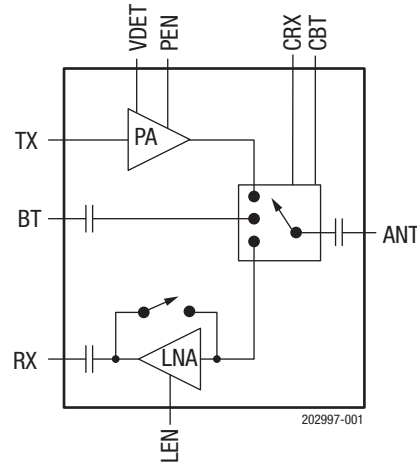

Figure 1. SKY85300-21 Block Diagram

Description

The SKY85300-21 is a complete 802.11 b/g/n 256 QAM WLAN RF front-end module (FEM) with a Bluetooth port. The device provides all the functionality of a fully matched power amplifier (PA), power detector, harmonic filter, low-noise amplifier (LNA), and single-pole, triple-throw (SP3T) switch.

The SKY85300-21 provides a complete 2.4 GHz WLAN RF solution from the output of the transceiver to the antenna, and from the antenna to the input of the transceiver. The LNA increases the receive sensitivity of embedded solutions to improve range or to overcome the insertion loss of cellular filters (often included for mobile applications).

The SKY85300-21 also includes a transmitter power detector with 20 dB of dynamic range, and a digital enable control for transmitter power ramp on/off control.

The device is provided in an ultracompact, 16-pin 3 x 3 mm Quad Flat No-Lead (QFN) package. A functional block diagram is shown in Figure 1. The pin configuration and package are shown in Figure 2. Signal pin assignments and functional pin descriptions are provided in Table 1.

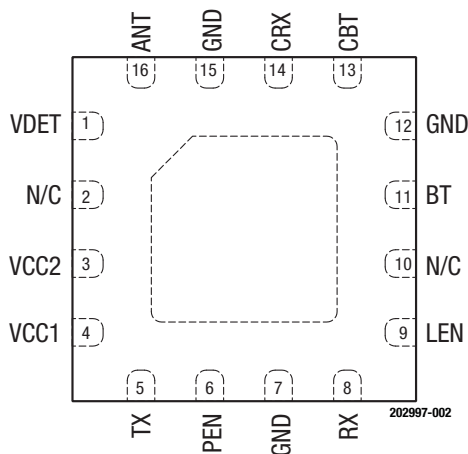

Figure 2. SKY85300-21 Pinout (Top View)

Table 1. SKY85300-21 Signal Descriptions

Pin	Name	Description	Pin	Name	Description
1	VDET	Power detector output voltage	9	LEN	LNA enable control input
2	N/C	No connection	10	N/C	No connection
3	VCC2	PA positive supply voltage	11	BT	Bluetooth input/output
4	VCC1	PA positive supply voltage	12	GND	Ground
5	TX	RF transmit PA input	13	CBT	Bluetooth antenna switch control
6	PEN	PA enable control input	14	CRX	Receive antenna switch control
7	GND	Ground	15	GND	Ground
8	RX	RF receive LNA output	16	ANT	Antenna

Technical Description

The SKY85300-21 is comprised of a high-efficiency 2.4 GHz PA, 2.4 GHz LNA, and 2.4 GHz SP3T switch. The device is fully-matched, and requires few external components for optimal performance, which makes it ideal for small portable/mobile applications. The FEM provides a typical gain of 26 dB. The LNA supports an enable/disable mode and bypass mode for power savings when not in receive mode. The PA can be shut off using the PA_EN signal (pin 6).

The low-loss SP3T switch provides the T/R switching function on the SKY85300-21.

Electrical and Mechanical Specifications

The absolute maximum ratings of the SKY85300-21 are provided in Table 2. The recommended operating conditions are specified in Table 3 and electrical specifications are provided in Tables 4 through 9.

The state of the SKY85300-21 is determined by the logic provided in Table 10.

Table 2. SKY85300-21 Absolute Maximum Ratings¹

Parameter	Symbol	Minimum	Maximum	Units
Supply voltage	V _{CC1} , V _{CC2}	-0.3	+5.5	V
DC input on control pins	V _{IN}	-0.3	+3.6	V
Transmit input power (ANT terminated in 50 Ω match)	P _{IN}		+5	dBm
Operating temperature	T _A	-40	+85	°C
Storage temperature	T _{ST}	-40	+150	°C
Electrostatic discharge: Human Body Model (HBM), Class 1C	ESD		1000	V

¹ Exposure to maximum rating conditions for extended periods may reduce device reliability. There is no damage to device with only one parameter set at the limit and all other parameters set at or below their nominal value. Exceeding any of the limits listed here may result in permanent damage to the device.

ESD HANDLING: *Although this device is designed to be as robust as possible, electrostatic discharge (ESD) can damage this device. This device must be protected at all times from ESD when handling or transporting. Static charges may easily produce potentials of several kilovolts on the human body or equipment, which can discharge without detection. Industry-standard ESD handling precautions should be used at all times.*

Table 3. SKY85300-21 Recommended Operating Conditions

Parameter	Symbol	Minimum	Typical	Maximum	Units
Supply voltage relative to GND = 0 V	VCC1, VCC2	3.0	5.0	5.25	V
Operating temperature	T _A	-40	+25	+85	°C

Table 4. SKY85300-21 Electrical Specifications: DC Characteristics¹**(VCC1 = VCC2 = 5.0 V, PEN = 3.3 V, T_A = 25 °C, All Unused Ports Terminated with 50 Ω, Unless Otherwise Noted)**

Parameter	Symbol	Test Condition	Min	Typical	Max	Units
Total supply current	I _{CC}	P _{OUT} = +21 dBm		200	230	mA
		P _{OUT} = +22 dBm		225		mA
		P _{OUT} = +24 dBm		290	320	mA
Current off	I _{CC_OFF}	No RF, CBT = PEN = CRX = LEN = 0 V		5		μA
Quiescent current	I _{CQ}	No RF		130	155	mA
LNA supply current	I _{CC_LNA}	LEN = CRX = 3.3 V		8	11	mA
LNA bypass supply current	I _{CC_LNA_BYP}	LEN = 0 V, CRX = 3.3 V	160	190	250	μA
BT port supply current	I _{CC_BT}	CBT = 3.3 V	160	190	250	μA

¹ Performance is guaranteed only under the conditions listed in this table.**Table 5. SKY85300-21 Electrical Specifications: Transmit Characteristics¹****(VCC1 = VCC2 = 5.0 V, PEN = 3.3 V, CBT = LEN = CRX = 0 V, T_A = 25 °C, All Unused Ports Terminated with 50 Ω, Unless Otherwise Noted)**

Parameter	Symbol	Test Condition	Min	Typical	Max	Units
Frequency range	f		2.4		2.5	GHz
Output power	P _{OUT}	With -45 dB EVM source:				
		DEVM = 1.8%, MCS9, HT20, DEVM, AT off	+19	+21		dBm
		DEVM = 3%, MCS7, HT20, DEVM, AT off	+20	+22		dBm
		CCK, mask compliant	+22	+24		dBm
Small signal gain	IS21		25	26	29	dB
Small signal gain variation over any 20 MHz band	ΔS21				±0.5	dB
2 nd harmonics	2fo	P _{OUT} = +24 dBm, 1 Mbps, 802.11b			-23	dBm/MHz
3 rd harmonics	3fo	P _{OUT} = +24 dBm, 1 Mbps, 802.11b			-25	dBm/MHz
Delay and rise/fall time	t _{DR} , t _{DF}	50% of V _{PEN} edge and 90%/10% of final output power level		400	700	ns
Input return loss	S11	@ TX port		-12		dB
Stability	Stab	CW, P _{IN} = -3 dBm, 0.1 GHz to 20 GHz, load VSWR = 6:1	All non-harmonically related outputs less than -43 dBm/MHz			
Ruggedness	RGGD	CW, P _{IN} = +5 dBm, 0.1 GHz to 20 GHz, load VSWR = 10:1	No permanent damage or performance degradation			

¹ Performance is guaranteed only under the conditions listed in this table.

Table 6. SKY85300-21 Electrical Specifications: Bluetooth Characteristics¹
(VCC1 = VCC2 = 5.0 V, CBT = 3.3 V, CRX = LEN = PEN = 0 V, TA = 25 °C, All Unused Ports Terminated with 50 Ω, Unless Otherwise Noted)

Parameter	Symbol	Test Condition	Min	Typical	Max	Units
Frequency range	f		2.4		2.5	GHz
Insertion loss	IL			0.9		dB
BT port return loss	S11			-12		dB
Switch isolation	Iso		20			dB

¹ Performance is guaranteed only under the conditions listed in this table.

Table 7. SKY85300-21 Electrical Specifications: Receive Characteristics¹
(VCC1 = VCC2 = 5.0 V, LEN = CRX = 3.3 V, PEN = CBT = 0 V, TA = 25 °C, All Unused Ports Terminated with 50 Ω, Unless Otherwise Noted)

Parameter	Symbol	Test Condition	Min	Typical	Max	Units
Frequency range	f		2.4		2.5	GHz
Small signal gain	S21	LNA enabled Bypass mode	+11.0 -9	+12.0 -8	+13.5 -7	dB dB
Noise figure	NF	From ANT to RX pins		2.0	2.5	dB
Third order input intercept point	IIP3	LNA enabled Bypass mode	0	+2 +20		dBm dBm
Input return loss	S11	LEN = 3.3 V LEN = 0 V	-10 -8	-12 -10		dB dB
Output return loss	S22		-10	-8		dB
Enable time	T _{EN}	10% to 90% of RX RF power from time that LEN is at 50%			400	ns
Switch isolation	Iso		20			dB

¹ Performance is guaranteed only under the conditions listed in this table.

Table 8. SKY85300-21 Electrical Specifications: Power Detector Characteristics¹
(VCC1 = VCC2 = 5.0 V, PEN = 3.3 V, CBT = LEN = CRX = 0 V, TA = 25 °C, Unless Otherwise Noted)

Parameter	Symbol	Test Condition	Min	Typical	Max	Units
Frequency range	f		2.4		2.5	GHz
Power detector range	PDR	CW, measured @ ANT	0		+25	dBm
Output impedance	PD _{LOAD}			2.5		kΩ
Output voltage	PDV	P _{OUT} = No RF, measured into 1 MΩ P _{OUT} = +21 dBm, CW, measured into 1 MΩ P _{OUT} = +24 dBm, CW, measured into 1 MΩ	0.18 0.65 0.90	0.205 0.75 1.00	0.235 0.85 1.10	V V V
Maximum output voltage	PDV _{MAX}				1.26	V
Power detector bandwidth	PD _{BW}			1		MHz

¹ Performance is guaranteed only under the conditions listed in this table.

Table 9. SKY85300-21 Electrical Specifications: Control Logic Characteristics¹
(VCC1 = VCC2 = 5.0 V, T_A = 25 °C, All Unused Ports Terminated with 50 Ω, Unless Otherwise Noted)

Parameter	Symbol	Test Condition	Min	Typical	Max	Units
Control voltage:	V _{IH}		2.7		3.6	V
	V _{IL}		0		0.4	V
Input current, high	I _{IH}	All pins except PEN PEN pin			20 100	μA μA
Input current, low	I _{IL}	All pins except PEN PEN pin			1 12.5	μA μA

¹ Performance is guaranteed only under the conditions listed in this table.

Table 10. SKY85300-21 Control Logic¹

Mode	CBT (Pin 13)	CRX (Pin 14)	LEN (Pin 9)	PEN (Pin 6)
All off	0	0	0	0
WLAN receive LNA	0	1	1	0
WLAN receive bypass	0	1	0	0
Bluetooth transmit/receive	1	0	0	0
WLAN transmit	0	0	0	1

¹ "1" = +3.3 V, "0" = 0 V. Any state not described in this table places the switch into an undefined state. An undefined state does not damage the device.

Evaluation Board Description

The SKY85300-21 Evaluation Board is used to test the performance of the SKY85300-21 FEM. A suggested application schematic diagram is shown in Figure 3. The Evaluation Board is shown in Figure 4. Component values for the SKY85300-21 Evaluation Board are listed in Table 11.

Evaluation Board Setup Procedure

1. Connect the system ground to pin 8 of connector J7.
2. Apply 5 V to pins 1 and 3 (VCC1 and VCC2) of connector J7.
3. Test the RF paths as described by the control logic in Table 10.
4. Connect a digital multimeter to pin 15 of connector J7 to monitor the power detector voltage.
5. Monitor the ANT-to-RX performance by applying an RF signal to J3 (ANT) and measuring the response from the J2 (RX) connector output.
6. Monitor the transmit performance by applying an RF signal to connector J1 (TX) and monitoring the output power on the antenna port connector J3 (ANT).

CAUTION: Be careful not to overdrive the amplifier by applying too much RF on the device input.

Evaluation Board Losses

The board losses from the RF connectors of the Evaluation Board to the pins of the SKY85300-21 are:

ANT: 0.22 dB
 BT: 0.22 dB
 RX: 0.29 dB
 TX: 0.35 dB

Circuit Design Considerations

The following design considerations are general in nature and must be followed regardless of final use or configuration:

- Paths to ground should be made as short as possible.
- The ground pad of the SKY85300-21 has special electrical and thermal grounding requirements. This pad is the main thermal conduit for heat dissipation. Because the circuit board acts as the heat sink, it must shunt as much heat as possible from the device.
- Therefore, design the connection to the ground pad to dissipate the maximum wattage produced by the circuit board. Multiple vias to the grounding layer are required.
- Optimum performance is guaranteed by following the application schematic, Bill of Materials (BOM), and Gerber files.
- The exposed die pad under the chip provides thermal and RF ground to the device. It is recommended that the maximum allowable number of vias be used to connect the PDB top metal (where the die is soldered) to internal ground plane(s) of the PCB.
- The RX, BT, and ANT ports are AC-coupled and do not require DC blocking capacitors. The TX port (pin 5) has an on-chip inductor to ground followed by a DC blocking capacitor between the inductor and the die. Therefore, there is no DC present on this port.
- If the TX port is connected to an external component with DC present, a 10 pF (component C9) general-purpose blocking capacitor is recommended. If the TX port is connected to an external component without DC present, the 10 pF capacitor can be removed.
- The 10 pF decoupling capacitors, C3 and C4, should be on the primary side of the board at a minimum manufacturable distance from the FEM.
- The component placement of the rest of the components not mentioned in this section is not critical.

NOTE: A poor connection between the ground pad and ground increases junction temperature (T_J), which reduces the life of the device.

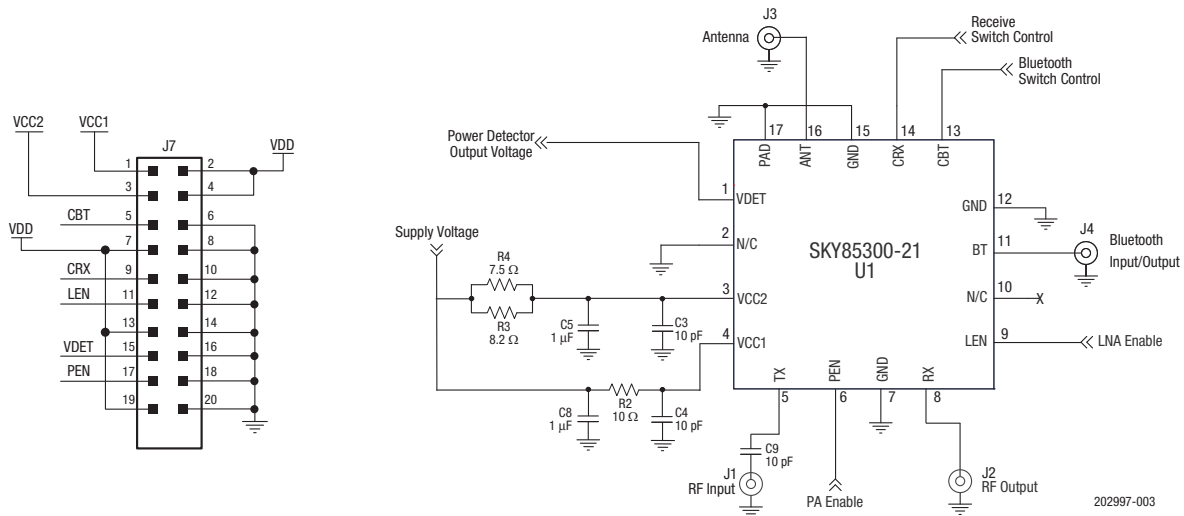

Figure 3. SKY85300-21 Application Schematic

Table 11. SKY85300-21 Evaluation Board Bill of Materials

Quantity	Component	Value	Vendor	Mfr Part Number	Size	Description
2	C5, C8	1 μF, 10 V, 10%, X5R	Murata	GRM155R61A105KE15D	0402	Monolithic ceramic capacitor
3	C3, C4, C9	10 pF, 50 V, 5%, COG	Murata	GRM1555C1H100JZ01	0402	Multilayer ceramic capacitor
1	R2	10 Ω 0.25 W, 5%	Panasonic	ERJ-2GEJ100X	0402	Thick film chip resistor
1	R3	8.2 Ω 0.25 W, 5%	Rohm	ESR03EZPJ8R2	0603	Anti-surge chip resistor
1	R4	7.5 Ω 0.25 W, 5%	Rohm	ESR03EZPJ7R5	0603	Anti-surge chip resistor
1	U1	SKY85300	Skyworks	SKY85300-21	QFN300x300	2 GHz FEM



Figure 4. SKY85300-21 Evaluation Board

Package Dimensions

The PCB board layout footprint for the SKY85300-21 is shown in Figure 5. Figure 6 shows a typical part marking.

Package dimensions are shown in Figure 7, and tape and reel dimensions are provided in Figure 8.

Package and Handling Information

Instructions on the shipping container label regarding exposure to moisture after the container seal is broken must be followed. Otherwise, problems related to moisture absorption may occur when the part is subjected to high temperature during solder assembly.

The SKY85300-21 is rated to Moisture Sensitivity Level 1 (MSL1) at 260 °C. It can be used for lead or lead-free soldering.

Care must be taken when attaching this product, whether it is done manually or in a production solder reflow environment. Production quantities of this product are shipped in a standard tape and reel format.

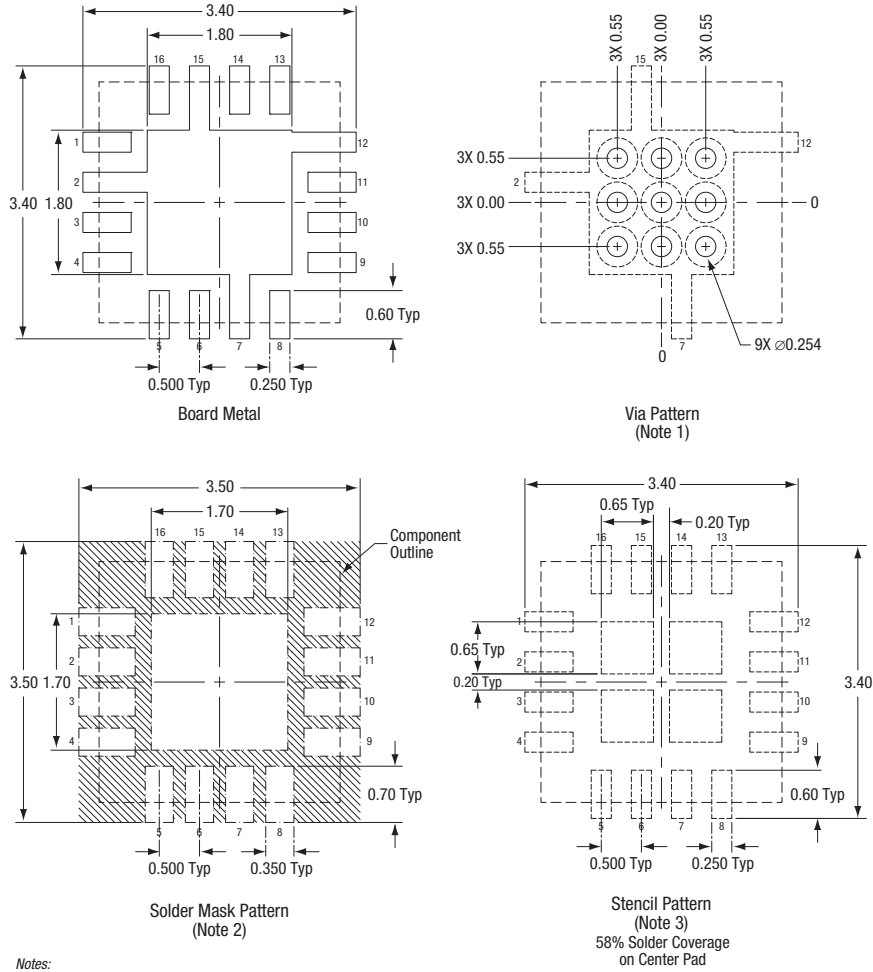

Figure 5. SKY85300-21 PCB Layout Footprint

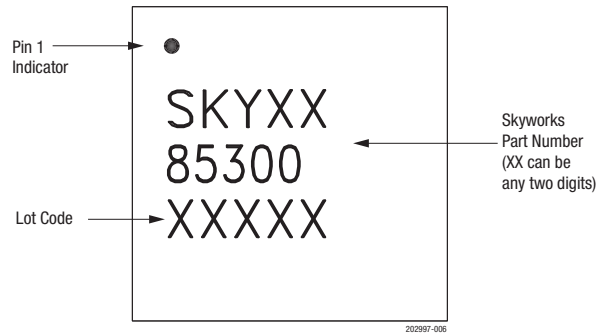

Figure 6. Typical Part Marking

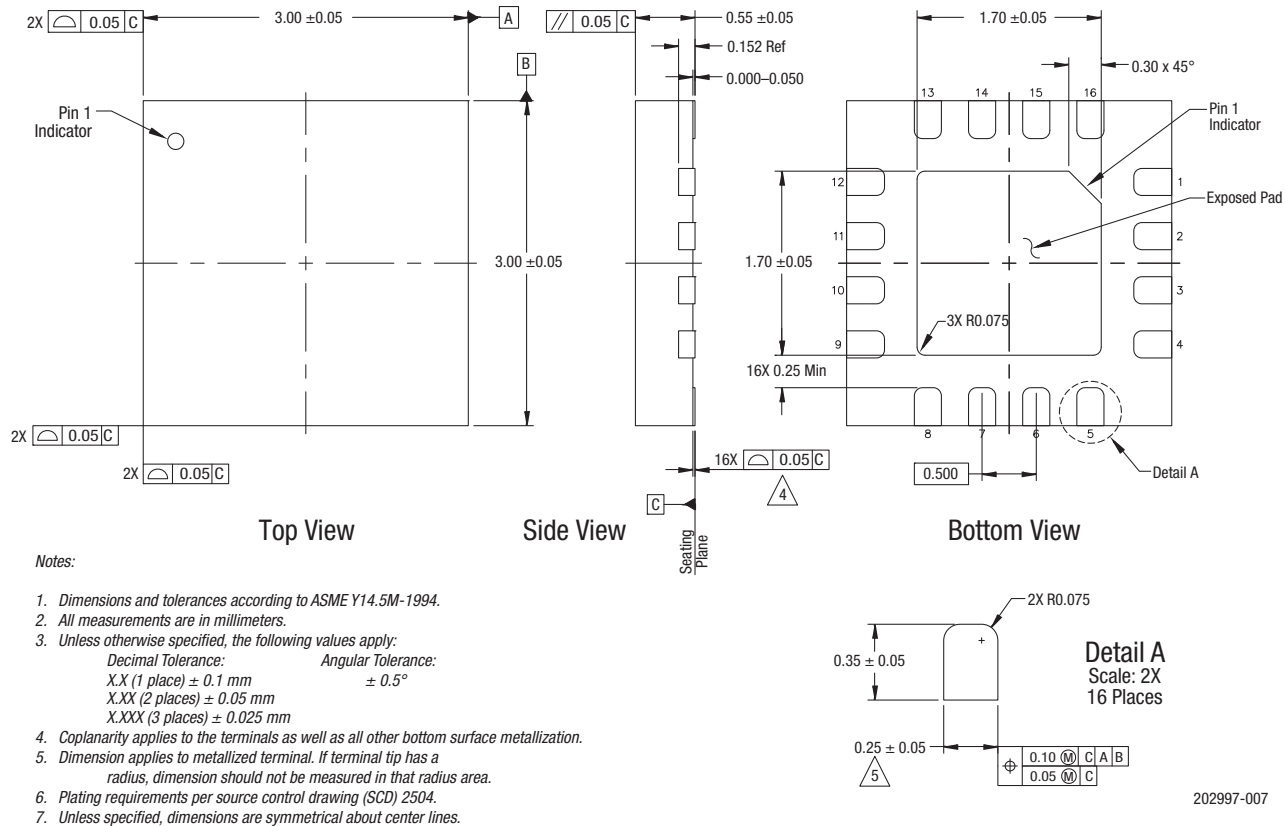

Figure 7. SKY85300-21 Package Dimensions

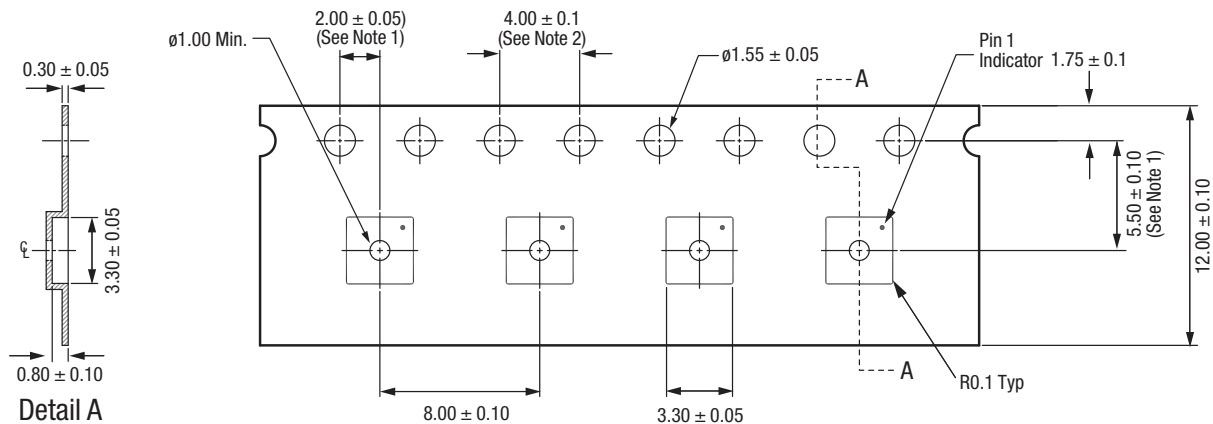

Figure 8. SKY85300-21 Tape and Reel Dimensions

Ordering Information

Model Name	Manufacturing Part Number	Evaluation Board Part Number
SKY85300-21: 2.4 GHz Front-End Module	SKY85300-21	SKY85300-21EK1

Copyright © 2013-2015, 2017 Skyworks Solutions, Inc. All Rights Reserved.

Information in this document is provided in connection with Skyworks Solutions, Inc. ("Skyworks") products or services. These materials, including the information contained herein, are provided by Skyworks as a service to its customers and may be used for informational purposes only by the customer. Skyworks assumes no responsibility for errors or omissions in these materials or the information contained herein. Skyworks may change its documentation, products, services, specifications or product descriptions at any time, without notice. Skyworks makes no commitment to update the materials or information and shall have no responsibility whatsoever for conflicts, incompatibilities, or other difficulties arising from any future changes.

No license, whether express, implied, by estoppel or otherwise, is granted to any intellectual property rights by this document. Skyworks assumes no liability for any materials, products or information provided hereunder, including the sale, distribution, reproduction or use of Skyworks products, information or materials, except as may be provided in Skyworks Terms and Conditions of Sale.

THE MATERIALS, PRODUCTS AND INFORMATION ARE PROVIDED "AS IS" WITHOUT WARRANTY OF ANY KIND, WHETHER EXPRESS, IMPLIED, STATUTORY, OR OTHERWISE, INCLUDING FITNESS FOR A PARTICULAR PURPOSE OR USE, MERCHANTABILITY, PERFORMANCE, QUALITY OR NON-INFRINGEMENT OF ANY INTELLECTUAL PROPERTY RIGHT; ALL SUCH WARRANTIES ARE HEREBY EXPRESSLY DISCLAIMED. SKYWORKS DOES NOT WARRANT THE ACCURACY OR COMPLETENESS OF THE INFORMATION, TEXT, GRAPHICS OR OTHER ITEMS CONTAINED WITHIN THESE MATERIALS. SKYWORKS SHALL NOT BE LIABLE FOR ANY DAMAGES, INCLUDING BUT NOT LIMITED TO ANY SPECIAL, INDIRECT, INCIDENTAL, STATUTORY, OR CONSEQUENTIAL DAMAGES, INCLUDING WITHOUT LIMITATION, LOST REVENUES OR LOST PROFITS THAT MAY RESULT FROM THE USE OF THE MATERIALS OR INFORMATION, WHETHER OR NOT THE RECIPIENT OF MATERIALS HAS BEEN ADVISED OF THE POSSIBILITY OF SUCH DAMAGE.

Skyworks products are not intended for use in medical, lifesaving or life-sustaining applications, or other equipment in which the failure of the Skyworks products could lead to personal injury, death, physical or environmental damage. Skyworks customers using or selling Skyworks products for use in such applications do so at their own risk and agree to fully indemnify Skyworks for any damages resulting from such improper use or sale.

Customers are responsible for their products and applications using Skyworks products, which may deviate from published specifications as a result of design defects, errors, or operation of products outside of published parameters or design specifications. Customers should include design and operating safeguards to minimize these and other risks. Skyworks assumes no liability for applications assistance, customer product design, or damage to any equipment resulting from the use of Skyworks products outside of stated published specifications or parameters.

Skyworks and the Skyworks symbol are trademarks or registered trademarks of Skyworks Solutions, Inc., in the United States and other countries. Third-party brands and names are for identification purposes only, and are the property of their respective owners. Additional information, including relevant terms and conditions, posted at www.skyworksinc.com, are incorporated by reference.