



Chipsmall Limited consists of a professional team with an average of over 10 year of expertise in the distribution of electronic components. Based in Hongkong, we have already established firm and mutual-benefit business relationships with customers from,Europe,America and south Asia,supplying obsolete and hard-to-find components to meet their specific needs.

With the principle of “Quality Parts,Customers Priority,Honest Operation,and Considerate Service”,our business mainly focus on the distribution of electronic components. Line cards we deal with include Microchip,ALPS,ROHM,Xilinx,Pulse,ON,Everlight and Freescale. Main products comprise IC,Modules,Potentiometer,IC Socket,Relay,Connector.Our parts cover such applications as commercial,industrial, and automotives areas.

We are looking forward to setting up business relationship with you and hope to provide you with the best service and solution. Let us make a better world for our industry!



Contact us

Tel: +86-755-8981 8866 Fax: +86-755-8427 6832

Email & Skype: info@chipsmall.com Web: www.chipsmall.com

Address: A1208, Overseas Decoration Building, #122 Zhenhua RD., Futian, Shenzhen, China



SL13A

Smart Sensory Tag Chip For Unique Identification, Monitoring and Data Logging

General Description

The SL13A is a semi-active tag chip optimized for single-cell, battery-powered smart labels with sensor functionality. It also supports fully-passive operation without battery. The chip is ideal for applications using thin and flexible batteries but can also be powered from the RF field (electromagnetic waves from an RFID reader).

The chip has a fully integrated temperature sensor with a nonlinearity of $\pm 0.5^{\circ}\text{C}$. The external sensor interface (S_{EXT}) is an analog input and allows the connection of an external sensor.

[Ordering Information](#) and [Content Guide](#) appear at end of datasheet.

Key Benefits & Features

The benefits and features of SL13A, Smart Sensory Tag Chip For Unique Identification, Monitoring and Data Logging are listed below:

Figure 1:
Added Value of Using SL13A

Benefits	Features
<ul style="list-style-type: none"> Versatile data logging with selectable options 	<ul style="list-style-type: none"> Programmable logging modes High temperature range: -40°C to 110°C
<ul style="list-style-type: none"> Logging storage capacity up to 762 events with time stamp 	<ul style="list-style-type: none"> On-chip 8k-bit EEPROM
	<ul style="list-style-type: none"> Real-time clock (RTC)
<ul style="list-style-type: none"> Supports data logging from various sensors 	<ul style="list-style-type: none"> On-chip temperature sensor
	<ul style="list-style-type: none"> Analog input for resistive external sensor
<ul style="list-style-type: none"> Flexible supply options ⁽¹⁾ 	<ul style="list-style-type: none"> Fully passive mode: no battery Semi-passive (BAP) mode: 1.5V or 3V battery
<ul style="list-style-type: none"> Provides supply for external circuitry 	<ul style="list-style-type: none"> Energy harvesting from reader field providing up to 4mA @3.4V
<ul style="list-style-type: none"> Long battery life of >1 year (with 25 mAH printed battery) 	<ul style="list-style-type: none"> Standby current (RTC running): $2\ \mu\text{A}_{\text{Typ}}$ (@1.5V) Operating current (logging, 20ms): $150\ \mu\text{A}_{\text{Typ}}$ (@1.5V)
<ul style="list-style-type: none"> Works with NFC-enabled phones and HF RFID readers 	<ul style="list-style-type: none"> ISO 15693 /NFC-V compliant cool-Log™ supporting logging functions

Benefits	Features
<ul style="list-style-type: none">• Parameter setting via serial interface	<ul style="list-style-type: none">• SPI port (slave) with access to EEPROM
<ul style="list-style-type: none">• Precludes manipulation and unauthorized usage of data	<ul style="list-style-type: none">• Perpetual password-protected EEPROM access from reader
<ul style="list-style-type: none">• Works in multi-tag environment	<ul style="list-style-type: none">• Anti-collision capability
<ul style="list-style-type: none">• Flexible delivery form	<ul style="list-style-type: none">• 16-LD QFN (5x5 mm)• Tested wafer (8")

Note(s) and/or Footnote(s):

1. After battery is exhausted, the chip will continue working in passive mode (no RTC).

Applications

The SL13A applications include:

- Monitoring and tracking of temperature-sensitive products
- Temperature monitoring of medical products
- Pharmaceutical logistics
- Monitoring of fragile goods transportation

Block Diagram

The functional blocks of this device for reference are shown below:

Figure 2:
SL13A Block Diagram

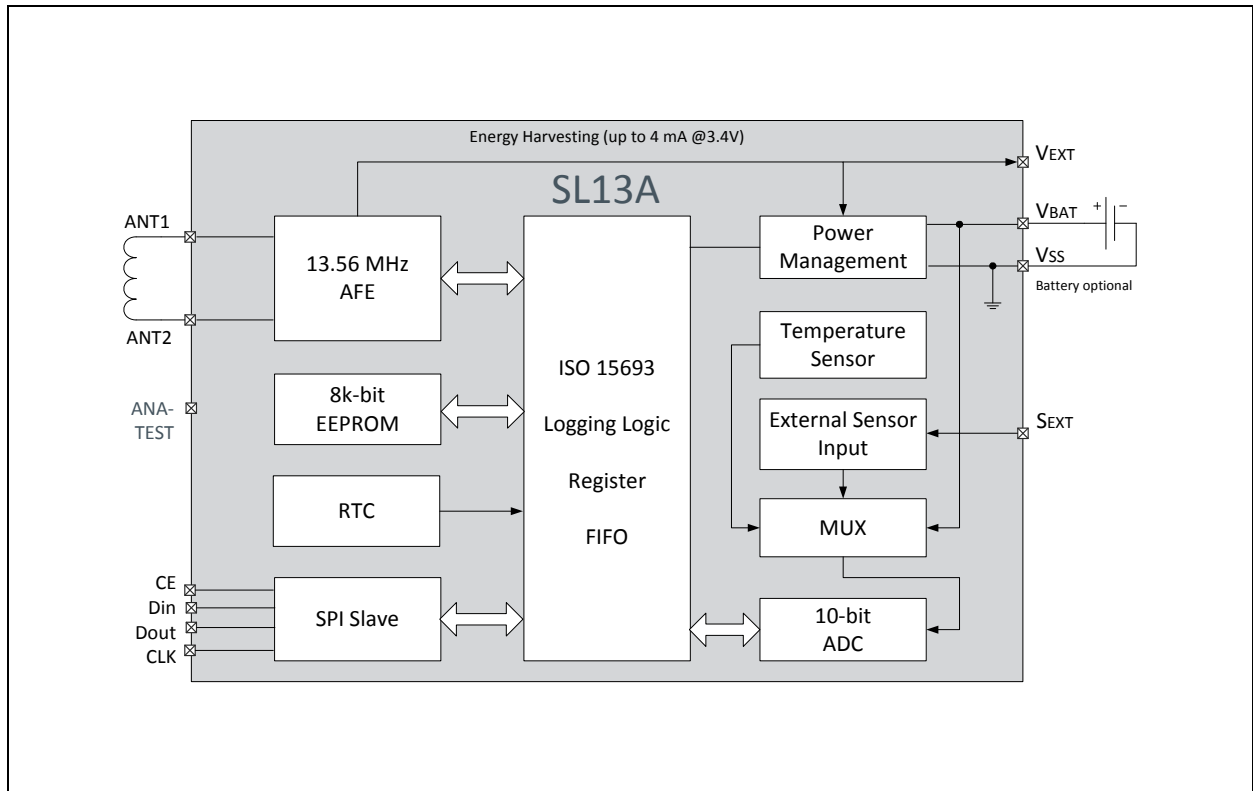

Pin and Pad Layout

The SL13A pin and pad layout is described below.

Figure 3:
QFN 16 Pinout

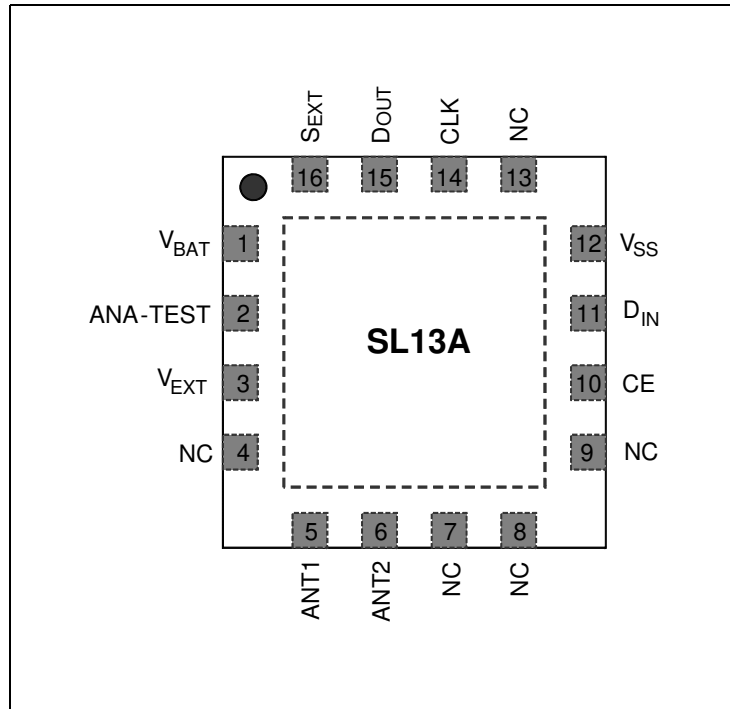

Figure 4:
Die Pad Layout

Die Pad Layout

The die size is 2.37mm x 2.24mm.
All dimensions are in microns.
Origin is on lower left corner of the chip,
the values show the pad center position.

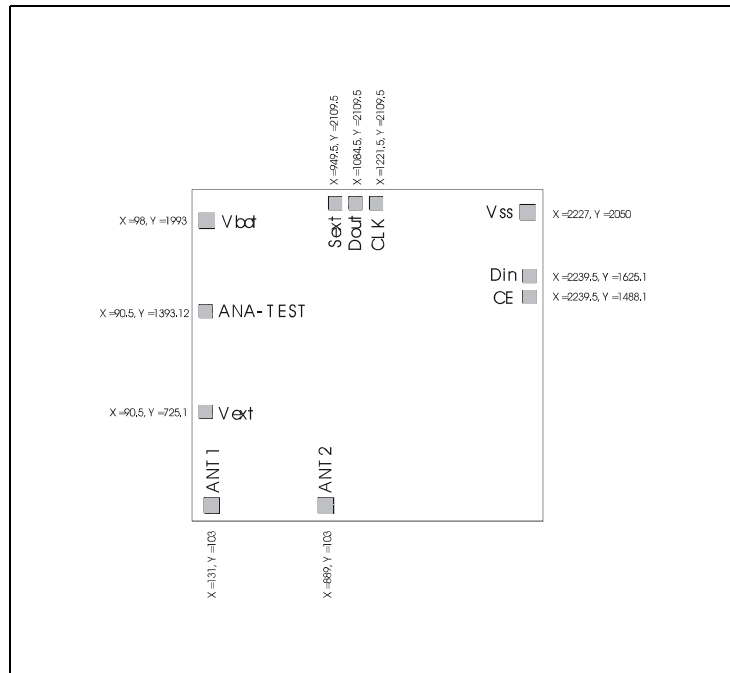

Figure 5:
Pin Description

Pin Number	Pin Name	Description
1	V _{BAT}	Battery input
2	ANA-TEST	Analog test output
3	V _{EXT}	Power output for external circuit (rectified RF voltage)
4	NC	Not connected
5	ANT1	Antenna coil
6	ANT2	Antenna coil
7	NC	Not connected
8	NC	Not connected
9	NC	Not connected
10	CE	SPI enable input
11	D _{IN}	SPI data in
12	V _{SS}	Negative supply and ground
13	NC	Not connected
14	CLK	SPI clock
15	D _{OUT}	SPI data out
16	S _{EXT}	Analog input for external sensor. The input voltage range is 0.3V to 0.6V

Absolute Maximum Ratings

Stresses beyond those listed under “Absolute Maximum Ratings” may cause permanent damage to the device. These are stress ratings only. Functional operation of the device at these or any other conditions beyond those indicated under [Operating Conditions](#) is not implied. Exposure to absolute maximum rating conditions for extended periods may affect device reliability.

Figure 6:
Absolute Maximum Ratings

Parameter	Min	Max	Unit	Note
Input Voltage Range	-0.3	3.7	V	All voltage values are with respect to substrate ground terminal V _{SS}
Maximum Current V _{EXT} , ANT1, ANT2		1	A	
ESD Rating, HBM	±2		kV	
Maximum Operating Virtual Junction Temperature, T _J		150	°C	
Storage Temperature Range, T _{stg}	-65	150	°C	
Package Body Temperature, T _{body}		260	°C	Norm: IPC/JEDEC J-STD-020 The reflow peak soldering temperature (body temperature) is specified according IPC/JEDEC J-STD-020 “Moisture/Reflow Sensitivity Classification for Non-hermetic Solid State Surface Mount Devices”.
Moisture Sensitivity Level (MSL)	3			Represents a maximum floor life time of 168h

Operating Conditions

(Operating free-air temperature range)

Figure 7:
Operating Conditions

Symbol	Parameter	Min	Typ	Max	Unit
V _{BAT}	Input Supply Voltage	1.2	1.5	3.3	V
T _A	Operating ambient temperature range	-40		110	°C

Electrical Characteristics

$T_A = 0^\circ\text{C}$ to 85°C , $V_{\text{BAT}} = 1.5\text{V}$, $\text{EN} = V_{\text{BAT}}$, $R_{\text{LOAD}} = \infty$, unless otherwise noted. Typical values are at $T_A = 35^\circ\text{C}$. ⁽²⁾

Figure 8:
Electrical Characteristics

Symbol	Parameter	Conditions	Min	Typ	Max	Unit
V_{BAT}	Operating Input Voltage	$T_A = 35^\circ\text{C}$	1.2		3.3	V
$V_{\text{BAT(SU)}}$	Minimum Start-Up Input Voltage	$T_A = 35^\circ\text{C}$		1.3		V
$I_{\text{BAT-OP}}$	Operating Current into V_{BAT}	Sensor and A/D converter active	100	150	300	μA
$I_{\text{BAT-SD}}$	Shutdown Current into V_{BAT}	$V_{\text{BAT}} = 1.5\text{V}$; $T_A = 35^\circ\text{C}$		100	500	nA
V_{EXT}	Output Voltage	see note (1)	3.2	3.4	3.5	V
I_{EXT}	Maximum Current, External	When RF field is present, from the V_{EXT} pin		4		mA
V_{IL}	Input Voltage Threshold, Low	CE, SCLK, SDATA	$V_{\text{SS}} - 0.3$		$V_{\text{SS}} + 0.3$	V
V_{IH}	Input Voltage Threshold, High	CE, SCLK, SDATA	$V_{\text{BAT}} - 0.3$		$V_{\text{BAT}} + 0.3$	V
V_{OL}	Output Voltage level, Low	DIGI_OUT	$V_{\text{SS}} - 0.3$		$V_{\text{SS}} + 0.3$	V
V_{OH}	Output Voltage level, High	DIGI_OUT	$V_{\text{BAT}} - 0.3$		$V_{\text{BAT}} + 0.3$	V
$V_{\text{S-EXT}}$	Sensor Input Voltage Range	S_{EXT}	0.3		0.6	V
$R_{\text{IN-EXT}}$	Sensor Input Impedance	S_{EXT}		1		$\text{M}\Omega$
f_c	Carrier Frequency		13.553	13.56	13.567	MHz
$T_{\text{S-R}}$	Temperature Sensor Range		-20		60	$^\circ\text{C}$
$T_{\text{E-R}}$	Extended temperature sensor range		-40		74	$^\circ\text{C}$
$T_{\text{S-O}}$	Temperature Sensor Offset at 35°C	One-point calibration at 35°C ⁽³⁾	-0.6		0.6	$^\circ\text{C}$
$T_{\text{S-GN}}$	Temperature Sensor Gain and nonlinearity error			± 0.5		$^\circ\text{C}$
$t_{\text{RTC-I}}$	Real-Time Clock, Interval	Programmable	1		32,768	Sec
$t_{\text{RTC-AT}}$	Real-Time Clock, Accuracy at 35°C	see note (4)	-0.5		+0.5	%

Symbol	Parameter	Conditions	Min	Typ	Max	Unit
$t_{\text{RTC-AF}}$	Real-Time Clock, Accuracy over the specified temperature range		-3		+3	%
EW_{CYC}	EEPROM Erase/Write Cycles	$T = 25^{\circ}\text{C}$	10,000			Cycles
t_{DR}	EEPROM Data Retention Time	$T = 55^{\circ}\text{C}$	10			Years
$t_{\text{E/W}}$	EEPROM Erase/Write Time	$T_{\text{A}} = 0^{\circ}\text{C}$ to 55°C	4	6	8	ms
t_{ADC}	ADC Conversion Time	see note (5)		7		ms
C_{T}	Internal Tuning Capacitor	Between ANT1 and ANT2 pins		25		pF

Note(s) and/or Footnote(s):

1. V_{EXT} is rectified RF voltage, for power supply of external circuits. It is limited to 3.4V, when enough signal is present on the coil. The maximum output current is 5mA and is dependent on the strength of the RF field.
2. Limits are 100% production tested at $T_{\text{A}} = 35^{\circ}\text{C}$. Limits over the operating temperature range are guaranteed by design.
3. During calibration on wafer sort, the chuck temperature variation is $\pm 0.5^{\circ}\text{C}$, which amounts to the major part of the accuracy error.
4. The real time oscillator frequency is trimmed on wafer sort at 35°C .
5. The conversion time includes the ADC setup time.

Detailed Description

The SL13A is designed for use in smart active labels (SAL) and smart passive labels. Smart active labels are defined as thin and flexible labels that contain an integrated circuit and a power source. SAL includes in its definition both “fully active” smart labels, and semi-active smart labels, also known as battery-assisted back-scattered passive labels, both of which enable enhanced functionality and superior performance over existing passive labels. The SL13A can be used in semi-active or fully-passive smart labels. The IC includes sensor functionality and logging of sensor data (see Figure 1 below).

The SL13A is operating at 13.56 MHz and is fully ISO 15693 compliant. The chip is supplied from a single-cell battery of typically 1.5V. The on-chip temperature sensor and real-time clock (RTC) accommodate temperature data logging.

Supply Arrangement

The SL13A is supplied from either the battery or through the electromagnetic waves from a reader. The device is normally supplied from the battery unless the battery voltage is too low - in this case the device is powered from the RF field. This functionality enables the read out of the log data even in case the battery is exhausted.

The chip automatically detects whether a 1.5V or 3V battery is connected and adapts accordingly. The voltage step-up converter provides an input voltage for the voltage regulator, which provides a regulated voltage of 2V nominal (internal digital supply). The maximum current available from V_{EXT} for external circuitry is 4mA (only when RF field is present) and is limited to 3.4V.

Analog Front End (AFE)

The analog front end is designed for 13.56 MHz according to ISO 15693. The incoming data are demodulated from the received ASK (Amplitude Shift Keying) signal which is 10 ~ 30% or 100% modulated. Outgoing data are generated by the SL13A load variation using Manchester coding with one or two sub-carrier frequencies of 423.75 KHz ($f_c/32$) or 484.28 KHz ($f_c/28$). The SL13A is compliant with the ISO 15693 recommendation for radio frequency power and signal interface.

Processing and Digital Control

The SL13A is fully ISO 15693 compliant. Both data coding modes (1 out of 256 and 1 out of 4) are supported by the SL13A. The reader (interrogator) makes mode selection within the SOF (Start of Frame).

The 1-of-256 data coding mode has a data rate of 1.65 kbit/s ($f_c/8192$) meaning that the transmission of one byte takes 4.833 ms. The 1-of-4 coding has a rate of 26.48 kbit/s ($f_c/512$) with the transmission of one byte taken 302.08 μ s.

Figure 9:
Response Data Rate

Data Rate	One Sub-carrier	Two Sub-carrier
Low	6.62 kbit/s ($f_c/2048$)	6.67 kbit/s ($f_c/2032$)
High	26.48 kbit/s ($f_c/512$)	26.69 kbit/s ($f_c/508$)

Serial Interface (SPI)

The integrated serial interface (SPI) can be used to read and write the embedded EEPROM and to set the parameters. The SPI interface is a secondary and test interface - the main interface is the RF ISO15693 interface.

Real-Time Clock (RTC)

The on-chip real-time clock (RTC) is started through the **START-LOG** command in which the start time is programmed in UTC format. The interval for sensing and data logging can be programmed in the range from 1 second up to 9 hours. The accuracy of the timer is $\pm 3\%$.

Temperature Sensor

The on-chip temperature sensor can measure the temperature in the range from -20°C to 60°C within the specified accuracy. The reference voltage for the A/D conversion is supplied from an on chip calibrated Bandgap reference.

External Sensor

The external sensor pin (S_{EXT}) can be used to connect an external sensor to the A/D converter. The voltage input range is 300mV – 600mV and is fixed. For extra low power applications the CE pin can switch the battery voltage for the time of the external sensor A/D converter, so the current from the battery into the sensor will flow only for this short time (max 5ms). This can be enabled when the External-sensor flag is set to 1 and the bit 19 in the Internal calibration data is set.

A/D Converter

An integrated 10-bit dual slope converter is used for the temperature, battery and external sensor voltage conversions.

EEPROM Organization and Security

The EEPROM is organized into 3 areas - the System area, User area and Measurement area. The System area has a fixed size and can be accessed only by the proprietary commands. It is protected by the Level 1 password - the System password. The User and Measurement areas reside in the same address space (256 blocks), but have separated passwords - the User password and the Measurement password. The User and Measurement areas can be accessed by the standard ISO15693 read and write commands. The User area size can be set by the Initialize command. The minimum User area size is 1 block, the maximum is 256 blocks. The size of the Measurement area is 256 blocks minus User area. All blocks are 32 bits wide.

The password protection restricts only the write-type commands. Read commands are always open. The password protection can be activated for every area individually by writing a value not equal to 0 to the password blocks.

The chip also supports a One-time use secure mode. When this mode is used, all Measurement blocks are automatically locked by the chip with the Start Log command. Those blocks cannot be unlocked anymore even if the Level 3 (measurement) password is known. This mode is intended for high security applications where the 32-bit password does not provide enough confidence.

Fully Passive Operation

The chip can be used in fully passive mode without a battery supply. In this mode all functions are active only when the antenna is in a RF field. For extended operation range in fully passive mode, connect a 2.2 μ F capacitor between the V_{EXT} and V_{SS} pins. The chip can be used also without this capacitor.

Functional Description

Figure 11 shows the command overview.

Figure 14 shows the different states and their interactions.

Initializing the Chip

A virgin chip (not initialized) can be initialized either through the SPI bus or through the electromagnetic field from a reader in the standby mode. The power source is either from a battery (V_{BAT}) or extracted from the RF field via the AFE circuit. After the initializing procedure, the chip will enter the ready mode.

If the External-Sensor flag is set, an external analog output sensor can be connected to the S_{EXT} pin.

Ready State

In the ready mode, all parameters can be set, read and changed through a reader with the appropriate passwords.

Active State

In active mode, the real-time clock (RTC) is running, the desired parameters are set and the on-chip temperature sensor is in standby.

Logging State

A log flag from the timer will enable the logging mode in which the sensor and the A/D converter will be activated, and the measured value will be stored in the EEPROM together with the time of the event. If the External Sensor flag is set, the external sensor will also be activated and the measured data stored. The A/D converter can be multiplexed between internal temperature sensor, external sensor or battery voltage. After the event, the chip will return to the active mode.

During the time of the logging procedure, the chip will not be able to receive any RF command. If an RF command is sent during this time, the chip will ignore it and will not send any reply.

Passive State

In passive mode, the chip waits for the presence of an RF field or for CE signal to go high. Current consumption from the battery in passive mode is <300nA.

Figure 10:
Overview of Operation States

State	CE	Description	I_{BAT} (Typ.)	Power from AFE
Passive	Low	Chip in passive state No current into V_{BAT}	<0.1 μA	No
Serial	High	Enables initializing and executing of all commands via the SPI bus		No
Ready	Low	Chip is initialized and all commands can be executed via the reader		Yes
Active	Low	RTC running Sensor standby	3 μA	No
Logging	Low	Sensor reading (on-chip temperature sensor, battery voltage level and/or external sensor through the S_{EXT} pin) Measured data stored in EEPROM RTC time stored in EEPROM	100 μA	No

State Diagram

Figure 11:
State Transition Diagram

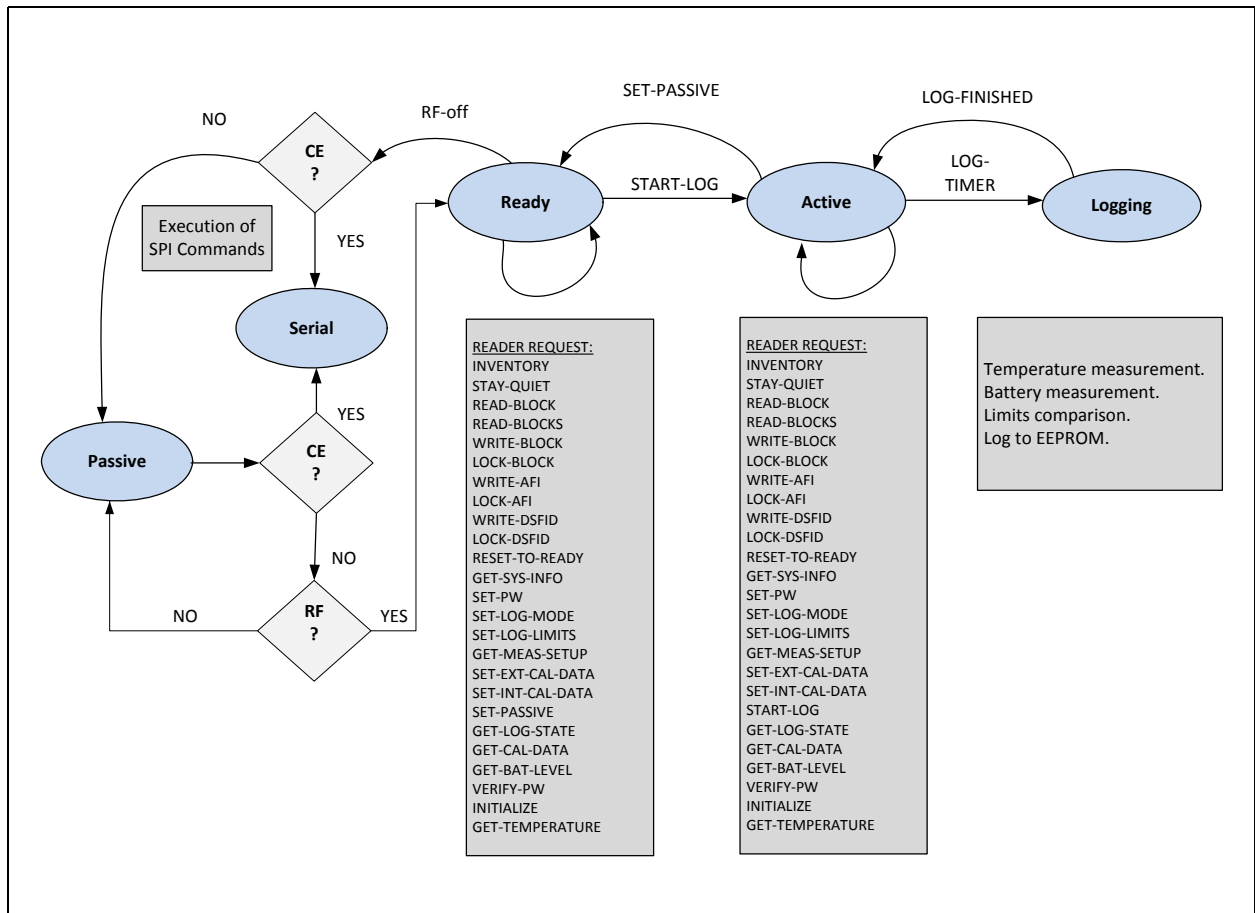

Commands

Request Command Structure

All commands, the standard ISO15693 and the cool-Log™ commands, have the same structure. All fields are sent LSbit first.

Figure 12:
Request Command Structure

SOF	Flags	Command Code	Parameters / Data	CRC	EOF
	8 bits	8 bits	n*8 bits	16 bits	

Response Structure

Figure 13:
Response Structure

SOF	Flags	Parameters / Data	CRC	EOF
	8 bits	n*8 bits	16 bits	

Figure 14:
cool-Log™ Command Overview

#	Command	Command Code	Allowed in Modes					Mode Change	Security Level	Definition
			Logging	Serial	Ready	Active	Passive			
01	Inventory	0x01	-	√	√	√	-	No	0	Multi-tag request, anti-collision
02	Stay Quiet	0x02	-	√	√	√	-	Yes	0	Sets the chip to quiet state within its basic mode
03	Read Block	0x20	-	√	√	√	-	No	0	Reads the requested block
04	Read Blocks	0x23	-	√	√	√	-	No	0	Reads the requested blocks
05	Write Block	0x21	-	√	√	√	-	No	2 or 3	Writes the requested block
06	Lock Block	0x22	-	√	√	√	-	No	2 or 3	Locks the requested block
07	Write AFI	0x27	-	√	√	√	-	No	1	Writes AFI (application family identifier) number into chip
08	Lock AFI	0x28	-	√	√	√	-	No	1	Locks the AFI block
09	Write DSF	0x29	-	√	√	√	-	No	1	Writes the DSF (data storage format) number into the chip
10	Lock DSFID	0x2A	-	√	√	√	-	No	1	Locks the DSFID block
11	Reset to Ready	0x26	-	√	√	√	-	Yes	0	Resets from Quiet state
12	Get System Info	0x2B	-	√	√	√	-	No	0	Read the System information block
13	Set PW	0xA0	-	√	√	√	-	No	1, 2, 3	Sets the passwords to EEPROM or opens access to the requested area
14	Set Log Mode	0xA1	-	√	√	-	-	No	1	Sets logging mode
15	Set Log Limits	0xA2	-	√	√	-	-	No	1	Sets the measurement limits for limits logging mode

#	Command	Command Code	Allowed in Modes					Mode Change	Security Level	Definition
			Logging	Serial	Ready	Active	Passive			
16	Get Measurement Setup	0xA3	-	√	√	√	-	No	0	Reads 4 system blocks - Start time, Log limits, Log mode, and Delay time + user area size
17	Set Ext. Calibration Data	0xA4	-	√	√	-	-	No	1	Sets the calibration data for the external sensor
18	Set Int. Calibration Data	0xA5	-	√	√	-	-	No	1	Sets the calibration data for the temperature sensor and timer
19	Set Passive	0xA6	-	√	-	√	-	Yes	1	Stops the log procedure and returns the chip to Standby mode
20	Start Log	0xA7	-	√	√	-	-	Yes	1	Starts the timer and the selected log procedure
21	Get Log State	0xA8	-	√	√	√	-	No	1	Gets the log state of the chip
22	Get Calibration Data	0xA9	-	√	√	√	-	No	0	Reads the internal and external calibration data
23	Get Battery Level	0xAA	-	√	√	√	-	No	0	Measures the battery voltage
24	Verify PW	0xAB	-	√	√	√	-	No	0	Verifies the password for the requested area
25	Initialize	0xAC	-	√	√	-	-	No	0	Initializes the chip and sets the user area size and the logging delay
26	Get Temperature	0xAD	-	√	√	√	-	No	0	Measures the temperature

Command Description

The commands are described below in detail.

- Inventory - #01
After receiving an **INVENTORY** request, all chips respond with their respective unique serial numbers (UID). One slot and multiple slot for anti-collision is supported.
- Stay Quiet - #02
When a chip receives a **STAY-QUIET** command, it enters the quiet state. In this state, the chip will not respond to Inventory commands. The chip leaves the Quiet state after receiving the Reset to Ready command.
- Read Block - #03
A memory block can be read with the **READ-BLOCK** command. Only the User and Measurement area are accessed by this command.
- Read Blocks - #04
Multiple blocks can be read with the **READ-BLOCKS** command. The maximum numbers of blocks in this command is 256.
- Write Block - #05
The **WRITE-BLOCK** command writes the requested block with the data contained in the request. Only User and Measurement data are accessed by this command.
Security levels: 2 for User data and 3 for Measurement data.
- Lock Block - #06
The **LOCK-BLOCK** command locks the requested block in the User and Measurement area. A locked block is permanently locked and cannot be unlocked anymore.
Security levels: 2 for User area and 3 for Measurement area.
- Write AFI - #07
The **WRITE-AFI** command writes the AFI number (application family identifier) into the memory.
Security level 1.
- Lock AFI - #08
The **LOCK-AFI** command locks the AFI block. It cannot be unlocked anymore.
Security level 1.
- Write DSFID - #09
The **WRITE-DSF** command is used to write the DSF (data storage format) number into the memory.
Security level 1.

- Lock DSFID - #10
The **LOCK-DSFID** command locks the DSFID block. It cannot be unlocked anymore.
Security level 1.
- Reset to Ready - #11
The **RESET-TO-READY** command puts the chip from Quiet to Ready state. It is effective only in Quiet state.
- Get System Info - #12
The **GET-SYSTEM-INFO** command gets the system information of the chip, including info flags, UID, chip revision, blocks and size.
- Set PW - #13
The **SET-PW** command sets the passwords for the selected password level. The passwords are parallel, which means that the user can protect individual areas and not affect the other areas.
Security levels 1, 2 or 3, respectively.

Figure 15:
Security Levels Explained

Security Level	Password	Access
0	No	All open
1	System password	System area
2	User password	User area
3	Measurement password	Measurement area

- Set Log Mode - #14
The **SET-LOG-MODE** command defines the sensor type (internal/external sensors), logging form, extreme upper limit and storage rules.
Security level 1.
- Set Log Limits - #15
The **SET-LOG-LIMITS** command sets the logging higher, lower and extreme lower limits. Those limits are used in the Limits modes and ignored in the Dense mode.
Security level 1.
- Get Measurement Setup - #16
The **GET-MEASUREMENT-SETUP** command reads 4 system blocks - Start time, Log limits, Log mode and Delay time.

- Set External Calibration Data - #17
The **SET-EXT-CAL-DATA** command sets the user calibration values. Those values have no effect on the internal calibration settings.
Security level 1.
- Set Internal Calibration Data - #18
The **SET-INT-CAL-DATA** command sets the calibration values for the internal temperature sensor.
Security level 1.
- Set Passive - #19
The **SET-PASSIVE** command stops the logging procedure and returns the chip to passive mode. It also stops the timer.
Security level 1.
- Start Log - #20
The **START-LOG** command starts the logging procedure and sets the Start time in UTC format. In logging state the chips automatically performs the measurements and data logging in the specified time intervals. Supported is also a delayed start, which means that the chip will start with the logging procedure with a specified delay after it receives the **START-LOG** command.
Security level 1.
- Get Log State - #21
The **GET-LOG-STATE** command gets the log state of following parameters: measurement status and out of limits counter. This gives the ability to quickly check the state of the package without the need to read the whole temperature data log.
- Get Calibration Data - #22
The **GET-CALIBRATION** command reads the calibration data for the internal and external sensors.
- Get Battery Level - #23
The **GET-BAT-LEVEL** command measures and reads the voltage level of the battery.
- Verify PW - #24
The **VERIFY-PW** command is used to verify the various passwords.

- Initialize - #25
 The **INITIALIZE** command sets the size of the user data area and sets the delay time. If the Secure flag is set, the chip automatically locks all measurement blocks. The command clears the measurement status and limits counter blocks.
 Security level 1.
- Get Temperature - #26
 The **GET-TEMPERATURE** command measures and reads the current chip temperature. *The measured temperature can be higher than the environment temperature, because of the chip self-heating through the reader RF field. To ensure correct measurement, the reader has to send this command as soon as possible after the RF field is turned on.*

Inventory - #01

Request:

SOF	FLAGS 8 bits	COMMAND CODE 0x01	MASK LENGTH 8 bits	MASK VALUE 0 - 64 bits	CRC 16 bits	EOF
------------	------------------------	-----------------------------	------------------------------	----------------------------------	-----------------------	------------

The AFI field is not supported by the SL13A.

Reply:

SOF	FLAGS 8 bits	DSFID 8 bits	UID 64 bits	CRC 16 bits	EOF
------------	------------------------	------------------------	-----------------------	-----------------------	------------

The manufacturers ID is 0x36. The UID consists of 8 bytes: E0 36 XX XX XX XX XX XX.

Stay Quiet - #02

Request:

SOF	FLAGS 8 bits	COMMAND CODE 0x02	UID 64 bits	CRC 16 bits	EOF
------------	------------------------	-----------------------------	-----------------------	-----------------------	------------

No Reply.

Read Block - #03

Request:

SOF	FLAGS 8 bits	COMMAND CODE 0x20	UID 64 bits	BLOCK ADDRESS 8 bits	CRC 16 bits	EOF
------------	------------------------	-----------------------------	-----------------------	--------------------------------	-----------------------	------------

Reply:

SOF	FLAGS 8 bits	BLOCK SECURITY STATUS 8 bits	DATA 32 bits	CRC 16 bits	EOF
------------	------------------------	--	------------------------	-----------------------	------------

Read Blocks - #04

Request:

SOF	FLAGS 8 bits	COMMAND CODE 0x23	UID 64 bits	BLOCK ADDRESS 8 bits	NUMBER OF BLOCKS 8 bits	CRC 16 bits	EOF
------------	------------------------	-----------------------------	-----------------------	--------------------------------	-----------------------------------	-----------------------	------------

Reply:

SOF	FLAGS 8 bits	BLOCK SECURITY STATUS 8 bits	DATA 32 bits	CRC 16 bits	EOF
Repeat As Requested					

Write Block - #05

Request:

SOF	FLAGS 8 bits	COMMAND CODE 0x21	UID 64 bits	BLOCK ADDRESS 8 bits	DATA 32 bits	CRC 16 bits	EOF
------------	------------------------	-----------------------------	-----------------------	--------------------------------	------------------------	-----------------------	------------

Reply:

SOF	FLAGS 8 bits	CRC 16 bits	EOF
------------	------------------------	-----------------------	------------

Lock Block - #06

Request:

SOF	FLAGS 8 bits	COMMAND CODE 0x22	UID 64 bits	BLOCK ADDRESS 8 bits	CRC 16 bits	EOF
------------	------------------------	-----------------------------	-----------------------	--------------------------------	-----------------------	------------

Reply:

SOF	FLAGS 8 bits	CRC 16 bits	EOF
------------	------------------------	-----------------------	------------

Write AFI - #07

Request:

SOF	FLAGS 8 bits	COMMAND CODE 0x27	UID 64 bits	AFI 8 bits	CRC 16 bits	EOF
------------	------------------------	-----------------------------	-----------------------	----------------------	-----------------------	------------

Reply:

SOF	FLAGS 8 bits	CRC 16 bits	EOF
------------	------------------------	-----------------------	------------

Lock AFI - #08

Request:

SOF	FLAGS 8 bits	COMMAND CODE 0x28	UID 64 bits	CRC 16 bits	EOF
------------	------------------------	-----------------------------	-----------------------	-----------------------	------------

Reply:

SOF	FLAGS 8 bits	CRC 16 bits	EOF
------------	------------------------	-----------------------	------------

Write DSFID - #09

Request:

SOF	FLAGS 8 bits	COMMAND CODE 0x29	UID 64 bits	DSIF 8 bits	CRC 16 bits	EOF
------------	------------------------	-----------------------------	-----------------------	-----------------------	-----------------------	------------

Reply:

SOF	FLAGS 8 bits	CRC 16 bits	EOF
------------	------------------------	-----------------------	------------

Lock DSFID - #10

Request:

SOF	FLAGS 8 bits	COMMAND CODE 0x2A	UID 64 bits	CRC 16 bits	EOF
------------	------------------------	-----------------------------	-----------------------	-----------------------	------------

Reply:

SOF	FLAGS 8 bits	CRC 16 bits	EOF
------------	------------------------	-----------------------	------------

Reset to Ready - #11

Request:

SOF	FLAGS 8 bits	COMMAND CODE 0x26	UID 64 bits	CRC 16 bits	EOF
------------	------------------------	-----------------------------	-----------------------	-----------------------	------------

Reply:

SOF	FLAGS 8 bits	CRC 16 bits	EOF
------------	------------------------	-----------------------	------------

Get System Info - #12

Request:

SOF	FLAGS 8 bits	COMMAND CODE 0x2B	UID 64 bits	CRC 16 bits	EOF
------------	------------------------	-----------------------------	-----------------------	-----------------------	------------

Reply:

SOF	FLAGS 8 bits	INFO FLAGS 8 bits	UID 64 bits	DSFID 8 bits	AFI 8 bits	TAG MEMORY SIZE 16 bits	IC REFERENCE 8 bits	CRC 16 bits	EOF
------------	------------------------	-----------------------------	-----------------------	------------------------	----------------------	-----------------------------------	-------------------------------	-----------------------	------------

Tag memory size field:

MSbit									LSbit
15	13	12	8	7	0				
RFU		BLOCK SIZE			NUMBER OF CLOCKS				

Set Password - #13

Request:

SOF	FLAGS 8 bits	COMMAND CODE 0xA0	UID 64 bits	PASSWORD LEVEL 8 bits	PASSWORD 32 bits	CRC 16 bits	EOF
------------	------------------------	-----------------------------	-----------------------	---------------------------------	----------------------------	-----------------------	------------

Reply:

SOF	FLAGS 8 bits	CRC 16 bits	EOF
------------	------------------------	-----------------------	------------

Password Level Field:

b0	b1	Password level
0	1	Level 1 - System
1	0	Level 2 - User
1	1	Level 3 - Measurement

b7	Operation
0	Open area
1	Write password

Set Password: bit6 - bit2 are all 0.

When bit7 of the Password level field is set to 1, the password is written to the requested level in the EEPROM. This operation enables password protection for the requested area, if the password is not 0. When the bit7 of the Password level field is 0, the requested area is opened with the included password. This command will not send back any error message, if the included password is not correct. One can verify the password with the Verify Password command.

Set Log Mode - #14

Request:

SOF	FLAGS 8 bits	COMMAND CODE 0xA1	UID 64 bits	LOG MODE 32 bits	CRC 16 bits	EOF
------------	------------------------	-----------------------------	-----------------------	----------------------------	-----------------------	------------

Reply:

SOF	FLAGS 8 bits	CRC 16 bits	EOF
------------	------------------------	-----------------------	------------

Set Log Limits - #15

Request:

SOF	FLAGS 8 bits	COMMAND CODE 0xA2	UID 64 bits	LOG LIMITS 32 bits	CRC 16 bits	EOF
------------	------------------------	-----------------------------	-----------------------	------------------------------	-----------------------	------------

Reply:

SOF	FLAGS 8 bits	CRC 16 bits	EOF
------------	------------------------	-----------------------	------------

Get Measurement Setup - #16

Request:

SOF	FLAGS 8 bits	COMMAND CODE 0xA3	UID 64 bits	CRC 16 bits	EOF
------------	------------------------	-----------------------------	-----------------------	-----------------------	------------

Reply:

SOF	FLAGS 8 bits	START TIME 32 bits	LOG LIMITS 32 bits	LOG MODE 32 bits	DELAY TIME 32 bits	CRC 16 bits	EOF
------------	------------------------	------------------------------	------------------------------	----------------------------	------------------------------	-----------------------	------------

Set External Calibration Data - #17

Request:

SOF	FLAGS 8 bits	COMMAND CODE 0xA4	UID 64 bits	EXT. CAL. DATA 32 bits	CRC 16 bits	EOF
------------	------------------------	-----------------------------	-----------------------	----------------------------------	-----------------------	------------

Reply:

SOF	FLAGS 8 bits	CRC 16 bits	EOF
------------	------------------------	-----------------------	------------