



Chipsmall Limited consists of a professional team with an average of over 10 year of expertise in the distribution of electronic components. Based in Hongkong, we have already established firm and mutual-benefit business relationships with customers from,Europe,America and south Asia,supplying obsolete and hard-to-find components to meet their specific needs.

With the principle of “Quality Parts,Customers Priority,Honest Operation,and Considerate Service”,our business mainly focus on the distribution of electronic components. Line cards we deal with include Microchip,ALPS,ROHM,Xilinx,Pulse,ON,Everlight and Freescale. Main products comprise IC,Modules,Potentiometer,IC Socket,Relay,Connector.Our parts cover such applications as commercial,industrial, and automotives areas.

We are looking forward to setting up business relationship with you and hope to provide you with the best service and solution. Let us make a better world for our industry!



## Contact us

Tel: +86-755-8981 8866 Fax: +86-755-8427 6832

Email & Skype: info@chipsmall.com Web: www.chipsmall.com

Address: A1208, Overseas Decoration Building, #122 Zhenhua RD., Futian, Shenzhen, China



## EProClock® GENERATOR FOR INTEL® CK505 COMPLIANCE

### Features

- Compliant Intel CK505 Clock spec
- Low power push-pull type differential output buffers
- Integrated resistors on differential clocks
- Wireless friendly 3-bits slew rate control on single-ended clocks
- Differential CPU clocks with pin selectable frequency
- 100 MHz Differential SRC clocks
- Selectable Differential SATA or SRC clocks
- 96 MHz Differential DOT clock
- 48 MHz USB clock
- Selectable 12 or 48 MHz clock
- 25 MHz output
- Buffered Reference Clock 14.318 MHz
- 14.318 MHz Crystal Input or Clock input
- I<sup>2</sup>C support with readback capabilities
- Triangular Spread Spectrum profile for maximum electromagnetic interference (EMI) reduction
- Industrial Temperature: -40 to 85 °C
- 3.3 V power supply
- 56-pin QFN package



### Selectable Differential SRC or CPU Clock

CPU	SRC	SATA	DOT96	48M	48M/12M	33M	25M	14.318M
x2/x3	x4/x7	x0/x1	x1	x1/2	x1	x2	x1	x1

### EProClock® Programmable Technology

- > 4000 bits of configurations
- Can be configured through SMBus or hard coded
- Custom frequency sets
- Differential skew control on true or compliment or both
- Differential duty cycle control on true or compliment or both
- Differential amplitude control
- Differential and single-ended slew rate control
- Program Internal or External series resistor on single-ended clocks
- Program different spread profiles
- Program different spread modulation rate

### Selectable Differential SRC or CPU Clock

CPU	SRC	SATA	DOT96	48M	48M/12M	33M	25M	14.318M
x2/x3	x4/x7	x0/x1	x1	x1/2	x1	x2	x1	x1

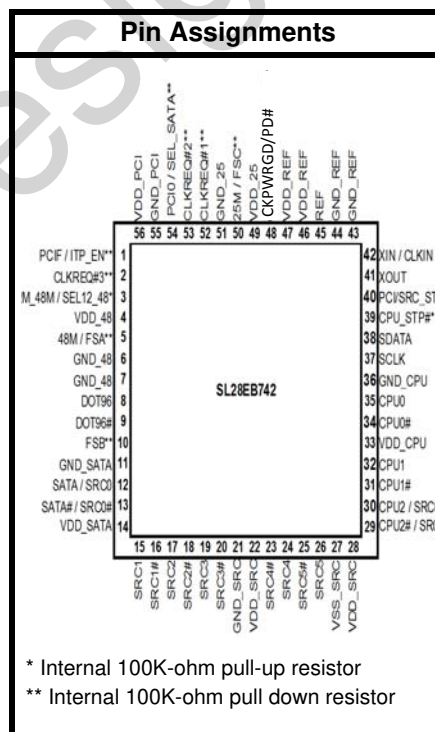

Patents pending

# SL28EB742

## Description

The SL28EB742 is a high-performance clock generator supporting Intel Cedarview platforms. The SL28EB742 is rated to support extended grade temperature. Utilizing an inexpensive 14.318 MHz crystal, it is capable of supporting multiple frequencies from four PLLs. The CPU clock can support a frequency range from 83.33 to 166 MHz by configuration of two strap pins. With a combination of strap pins and an I<sup>2</sup>C interface, the device allows maximum configurability.

EProClock<sup>®</sup> is the world's first non-volatile programmable clock. The EProClock<sup>®</sup> technology allows board designer to promptly achieve optimum compliance and clock signal integrity; historically, attainable typically through device and/or board redesigns. EProClock<sup>®</sup> technology can be configured through SMBus or hard coded.

## Functional Block Diagram

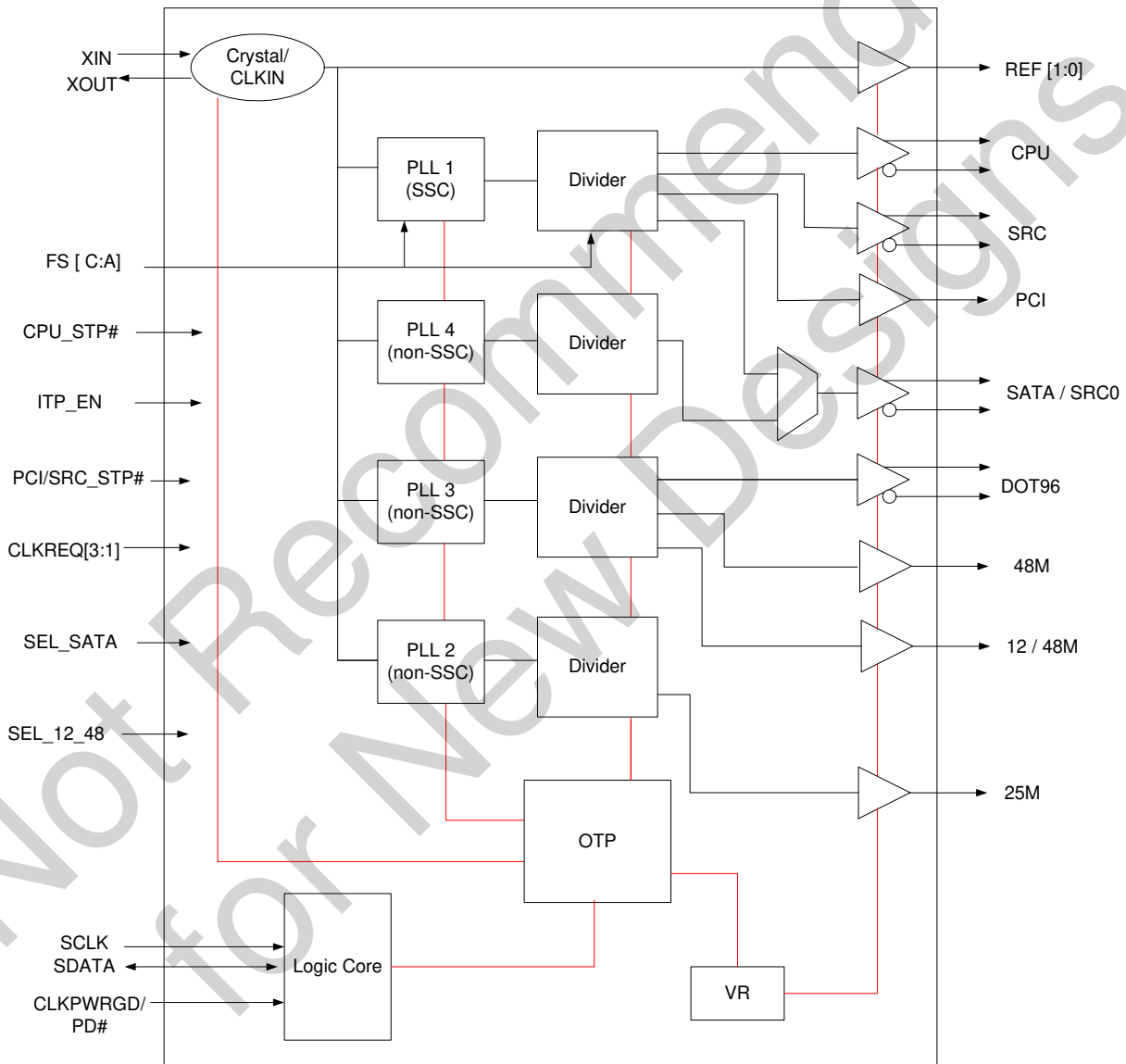

---

**TABLE OF CONTENTS**

---

<b><u>Section</u></b>	<b><u>Page</u></b>
<b>1. Electrical Specifications</b> .....	<b>4</b>
<b>2. Functional Description</b> .....	<b>11</b>
2.1. Powerdown (PD#) Clarification .....	11
2.2. Powerdown (PD#) Assertion .....	11
2.3. Powerdown (PD#) Deassertion .....	12
2.4. CPU_STP# Assertion .....	14
2.5. CPU_STP# Deassertion .....	14
2.6. PCI/SRC_STP# Assertion .....	15
2.7. PCI/SRC_STP# Deassertion .....	15
<b>3. Test and Measurement Setup</b> .....	<b>16</b>
3.1. Single-ended Clocks .....	16
3.2. Differential Clock Signals .....	17
<b>4. Control Registers</b> .....	<b>19</b>
4.1. Frequency Select Pin FS .....	19
4.2. Serial Data Interface .....	20
4.3. Data Protocol .....	20
<b>5. Pin Descriptions: 56-Pin QFN</b> .....	<b>35</b>
<b>6. Ordering Guide</b> .....	<b>39</b>
<b>7. Package Outline</b> .....	<b>40</b>
<b>Document Change List</b> .....	<b>42</b>
<b>Contact Information</b> .....	<b>43</b>

# SL28EB742

## 1. Electrical Specifications

**Table 1. Recommended Operating Conditions**

(VDD = 3.3 V, TA = 25 °C)

Parameter	Symbol	Test Condition	Min	Typ	Max	Unit
Supply Voltage (extended)	VDD <sub>(industrial)</sub>	3.3 V ±5%	3.13	3.3	3.46	V
Supply Voltage (commercial)	VDD <sub>(commercial)</sub>	3.3 V ±10%	2.97	3.3	3.63	V

**Table 2. DC Electrical Specifications**

Parameter	Symbol	Test Condition	Min	Max	Unit
3.3 V Operating Voltage	VDD core	3.3 ± 5%	3.135	3.465	V
3.3 V Input High Voltage (SE)	V <sub>IH</sub>		2.0	V <sub>DD</sub> + 0.3	V
3.3 V Input Low Voltage (SE)	V <sub>IL</sub>		V <sub>SS</sub> - 0.3	0.8	V
Input High Voltage	V <sub>IHI2C</sub>	SDATA, SCLK	2.2	—	V
Input Low Voltage	V <sub>ILI2C</sub>	SDATA, SCLK	—	1.0	V
FS Input High Voltage	V <sub>IH_FS</sub>		0.7	V <sub>DD</sub> +0.3	V
FS Input Low Voltage	V <sub>IL_FS</sub>		V <sub>SS</sub> - 0.3	0.35	V
Input High Leakage Current	I <sub>IH</sub>	Except internal pull-down resistors, 0 < V <sub>IN</sub> < V <sub>DD</sub>	—	5	μA
Input Low Leakage Current	I <sub>IL</sub>	Except internal pull-up resistors, 0 < V <sub>IN</sub> < V <sub>DD</sub>	-5	—	μA
3.3 V Output High Voltage (SE)	V <sub>OH</sub>	I <sub>OH</sub> = -1 mA	2.4	—	V
3.3 V Output Low Voltage (SE)	V <sub>OL</sub>	I <sub>OL</sub> = 1 mA	—	0.4	V
High-impedance Output Current	I <sub>OZ</sub>		-10	10	μA
Input Pin Capacitance	C <sub>IN</sub>		1.5	5	pF
Output Pin Capacitance	C <sub>OUT</sub>			6	pF
Pin Inductance	L <sub>IN</sub>		—	7	nH
Power Down Current	IDD_PD		—	1	mA
Dynamic Supply Current	IDD_3.3 V	All outputs enabled. SE clocks with 5" traces. Differential clocks with 5" traces. Loading per CK505 spec.	—	115	mA

Table 3. AC Electrical Specifications

Parameter	Symbol	Test Condition	Min	Max	Unit
Long-term Accuracy	$L_{ACC}$	Measured at VDD/2 differential	—	250	ppm
<b>Clock Input</b>					
CLKIN Duty Cycle	$T_{DC}$	Measured at VDD/2	47	53	%
CLKIN Rise and Fall Times	$T_R/T_F$	Measured between 0.2 V <sub>DD</sub> and 0.8 V <sub>DD</sub>	0.5	4.0	V/ns
CLKIN Cycle to Cycle Jitter	$T_{CCJ}$	Measured at VDD/2	—	250	ps
CLKIN Long Term Jitter	$T_{LTJ}$	Measured at VDD/2	—	350	ps
Input High Voltage	$V_{IH}$	XIN / CLKIN pin	2	VDD+0.3	V
Input Low Voltage	$V_{IL}$	XIN / CLKIN pin	—	0.8	V
Input High Current	$I_{IH}$	XIN / CLKIN pin, V <sub>IN</sub> = VDD	—	35	μA
Input Low Current	$I_{IL}$	XIN / CLKIN pin, 0 < V <sub>IN</sub> < 0.8	-35	—	μA
<b>CPU at 0.7 V</b>					
CPU Duty Cycle	$T_{DC}$	Measured at 0 V differential	45	55	%
83.33 MHz CPU Period	$T_{PERIOD}$	Measured at 0 V differential at 0.1s	11.99880	12.00120	ns
83.33 MHz CPU Period, SSC	$T_{PERIODSS}$	Measured at 0 V differential at 0.1s	12.02887 2	12.03128	ns
83.33 MHz CPU Absolute Period	$T_{PERIODAbs}$	Measured at 0 V differential at 1 clock	11.18969	12.16344	ns
83.33 MHz CPU Absolute Period, SSC	$T_{PERIODSSAbs}$	Measured at 0 V differential at 1 clock	11.89687	12.16344	ns
100 MHz CPU Period	$T_{PERIOD}$	Measured at 0 V differential at 0.1s	9.99900	10.0010	ns
100 MHz CPU Period, SSC	$T_{PERIODSS}$	Measured at 0 V differential at 0.1s	10.02406	10.02607	ns
100 MHz CPU Absolute Period	$T_{PERIODAbs}$	Measured at 0 V differential at 1 clock	9.87400	10.1260	ns
100 MHz CPU Absolute Period, SSC	$T_{PERIODSSAbs}$	Measured at 0 V differential at 1 clock	9.87406	10.1762	ns
133 MHz CPU Period	$T_{PERIOD}$	Measured at 0 V differential at 0.1s	7.49925	7.50075	ns
133 MHz CPU Period, SSC	$T_{PERIODSS}$	Measured at 0 V differential at 0.1s	7.51804	7.51955	ns
133 MHz CPU Absolute Period	$T_{PERIODAbs}$	Measured at 0 V differential at 1 clock	7.41425	7.58575	ns
133 MHz CPU Absolute period, SSC	$T_{PERIODSSAbs}$	Measured at 0 V differential at 1 clock	7.41430	7.62340	ns

# SL28EB742

**Table 3. AC Electrical Specifications (Continued)**

Parameter	Symbol	Test Condition	Min	Max	Unit
166 MHz CPU Period	$T_{PERIOD}$	Measured at 0 V differential at 0.1s	5.99940	6.00060	ns
166 MHz CPU Period, SSC	$T_{PERIODSS}$	Measured at 0 V differential at 0.1s	6.01444	6.01564	ns
166 MHz CPU Absolute period	$T_{PERIODAbs}$	Measured at 0 V differential at 1 clock	5.91440	6.08560	ns
166 MHz CPU Absolute period, SSC	$T_{PERIODSSAbs}$	Measured at 0 V differential at 1 clock	5.91444	6.11572	ns
CPU Cycle to Cycle Jitter	$T_{CCJ}$	Measured at 0 V differential	—	85	ps
CPU Cycle to Cycle Jitter for CPU 2	$T_{CCJ} (CPU2)$	Measured at 0 V differential	—	125	ps
CPU0 to CPU1 skew	Skew	Measured at 0 V differential	—	100	ps
Long-term Accuracy	$L_{ACC}$	Measured at 0 V differential	—	100	ppm
CPU Rising/Falling Slew rate	$T_R / T_F$	Measured differentially from $\pm 150$ mV	2.5	8	V/ns
Rise/Fall Matching	$T_{RFM}$	Measured single-endedly from $\pm 75$ mV	—	20	%
Voltage High	$V_{HIGH}$			1.15	V
Voltage Low	$V_{LOW}$		-0.3	—	V
Crossing Point Voltage at 0.7 V Swing	$V_{OX}$		300	550	mV
<b>SRC at 0.7 V</b>					
SRC Duty Cycle	$T_{DC}$	Measured at 0 V differential	45	55	%
100 MHz SRC Period	$T_{PERIOD}$	Measured at 0 V differential at 0.1s	9.99900	10.0010	ns
100 MHz SRC Period, SSC	$T_{PERIODSS}$	Measured at 0 V differential at 0.1s	10.02406	10.02607	ns
100 MHz SRC Absolute Period	$T_{PERIODAbs}$	Measured at 0 V differential at 1 clock	9.87400	10.1260	ns
100 MHz SRC Absolute Period, SSC	$T_{PERIODSSAbs}$	Measured at 0 V differential at 1 clock	9.87406	10.1762	ns
Any SRC Clock Skew from the earliest bank to the latest bank	$T_{SKEW}(\text{window})$	Measured at 0 V differential	—	3.0	ns
SRC Cycle to Cycle Jitter	$T_{CCJ}$	Measured at 0 V differential	—	85	ps
SRC Long Term Accuracy	$L_{ACC}$	Measured at 0 V differential	—	100	ppm
SRC Rising/Falling Slew Rate	$T_R / T_F$	Measured differentially from $\pm 150$ mV	2.5	8	V/ns

Table 3. AC Electrical Specifications (Continued)

Parameter	Symbol	Test Condition	Min	Max	Unit
Rise/Fall M-atching	$T_{RFM}$	Measured single-endedly from $\pm 75$ mV	—	20	%
Voltage High	$V_{HIGH}$			1.15	V
Voltage Low	$V_{LOW}$		-0.3	—	V
Crossing Point Voltage at 0.7 V Swing	$V_{OX}$		300	550	mV
<b>DOT96 at 0.7 V</b>					
DOT96 Duty Cycle	$T_{DC}$	Measured at 0 V differential	45	55	%
DOT96 Period	$T_{PERIOD}$	Measured at 0 V differential at 0.1s	10.4156	10.4177	ns
DOT96 Absolute Period	$T_{PERIODAbs}$	Measured at 0 V differential at 0.1s	10.1656	10.6677	ns
DOT96 Cycle to Cycle Jitter	$T_{CCJ}$	Measured at 0 V differential at 1 clock	—	250	ps
DOT96 Long Term Accuracy	$L_{ACC}$	Measured at 0V differential at 1 clock	—	100	ppm
DOT96 Rising/Falling Slew Rate	$T_R / T_F$	Measured differentially from $\pm 150$ mV	2.5	8	V/ns
Rise/Fall Matching	$T_{RFM}$	Measured single-endedly from $\pm 75$ mV	—	20	%
Voltage High	$V_{HIGH}$			1.15	V
Voltage Low	$V_{LOW}$		-0.3	—	V
Crossing Point Voltage at 0.7 V Swing	$V_{OX}$		300	550	mV
<b>SATA at 0.7 V</b>					
SATAM Duty Cycle	$T_{DC}$	Measured at 0V differential	45	55	%
SATA Cycle to Cycle Jitter	$T_{CCJ}$	Measured at 0V differential at 1 clock	—	125	ps
SATA Long Term Accuracy	$L_{ACC}$	Measured at 0V differential at 1 clock	—	100	ppm
SATA Rising/Falling Slew Rate	$T_R / T_F$	Measured differentially from $\pm 150$ mV	2.5	8	V/ns
Rise/Fall Matching	$T_{RFM}$	Measured single-endedly from $\pm 75$ mV	—	20	%
Voltage High	$V_{HIGH}$			1.15	V
Voltage Low	$V_{LOW}$		-0.3	—	V

# SL28EB742

**Table 3. AC Electrical Specifications (Continued)**

Parameter	Symbol	Test Condition	Min	Max	Unit
Crossing Point Voltage at 0.7 V Swing	$V_{OX}$		300	550	mV
<b>PCI/PCIF at 3.3 V</b>					
PCI Duty Cycle	$T_{DC}$	Measurement at 1.5 V	45	55	%
Spread Disabled PCIF/PCI Period	$T_{PERIOD}$	Measurement at 1.5 V	29.99700	30.00300	ns
Spread Enabled PCIF/PCI Period	$T_{PERIODSS}$	Measurement at 1.5 V	30.08421	30.23459	ns
Spread Disabled PCIF/PCI Period	$T_{PERIODAbs}$	Measurement at 1.5 V	29.49700	30.50300	ns
Spread Enabled PCIF/PCI Period	$T_{PERIODSSAbs}$	Measurement at 1.5 V	29.56617	30.58421	ns
Spread Enabled PCIF and PCI High Time	$T_{HIGH}$	Measurement at 2 V	12.27095	16.27995	ns
Spread Enabled PCIF and PCI Low Time	$T_{LOW}$	Measurement at 0.8 V	11.87095	16.07995	ns
Spread Disabled PCIF and PCI High Time	$T_{HIGH}$	Measurement at 2.0 V	12.27365	16.27665	ns
Spread Disabled PCIF and PCI Low Time	$T_{LOW}$	Measurement at 0.8 V	11.87365	16.07665	ns
PCIF/PCI Rising/Falling Slew Rate	$T_R / T_F$	Measured between 0.8 V and 2.0 V	1.0	4.0	V/ns
Any PCI clock to Any PCI clock Skew	$T_{SKEW}$	Measurement at 1.5 V	—	1000	ps
PCIF and PCI Cycle to Cycle Jitter	$T_{CCJ}$	Measurement at 1.5 V	—	300	ps
PCIF/PCI Long Term Accuracy	$L_{ACC}$	Measurement at 1.5 V	—	100	ppm
<b>48M, 12_48M at 3.3 V</b>					
Duty Cycle	$T_{DC}$	Measurement at 1.5 V	45	55	%
48 MHz Period	$T_{PERIOD}$	Measurement at 1.5 V	20.83125	20.83542	ns
48 MHz Absolute Period	$T_{PERIODAbs}$	Measurement at 1.5 V	20.48125	21.18542	ns
48 MHz High Time	$T_{HIGH}$	Measurement at 2 V	8.216563	11.15198	ns
48 MHz Low Time	$T_{LOW}$	Measurement at 0.8 V	7.816563	10.95198	ns
Rising and Falling Edge Rate	$T_R / T_F$ (48M)	Measured between 0.8 V and 2.0 V	1.0	2.0	V/ns
Rising and Falling Edge Rate	$T_R / T_F$ (12_48M)	Measured between 0.8 V and 2.0 V	1.0	2.0	V/ns
Cycle to Cycle Jitter	$T_{CCJ}$	Measurement at 1.5 V	—	300	ps

Table 3. AC Electrical Specifications (Continued)

Parameter	Symbol	Test Condition	Min	Max	Unit
48M Long Term Accuracy	L <sub>ACC</sub>	Measurement at 1.5 V	—	100	ppm
<b>25M at 3.3 V</b>					
Duty Cycle	T <sub>DC</sub>	Measurement at 1.5 V	45	55	%
Period	T <sub>PERIOD</sub>	Measurement at 1.5 V	39.996	40.004	ns
Absolute Period	T <sub>PERIODAbs</sub>	Measurement at 1.5 V	39.32360	40.67640	ns
Rising and Falling Edge Rate	T <sub>R</sub> / T <sub>F</sub>	Measured between 0.8 V and 2.0 V	1.0	4.0	V/ns
Cycle to Cycle Jitter	T <sub>CCJ</sub>	Measurement at 1.5 V	—	300	ps
25M Long Term Accuracy	L <sub>ACC</sub>	Measured at 1.5 V	—	100	ppm
<b>14.318M, at 3.3 V</b>					
Duty Cycle	T <sub>DC</sub>	Measurement at 1.5 V	45	55	%
Period	T <sub>PERIOD</sub>	Measurement at 1.5 V	69.82033	69.86224	ns
Absolute Period	T <sub>PERIODAbs</sub>	Measurement at 1.5 V	68.83429	70.84826	ns
High Time	T <sub>HIGH</sub>	Measurement at 2 V	29.97543	38.46654	ns
Low Time	T <sub>LOW</sub>	Measurement at 0.8 V	29.57543	38.26654	ns
Rising and Falling Edge Rate	T <sub>R</sub> / T <sub>F</sub>	Measured between 0.8 V and 2.0 V	1.0	4.0	V/ns
Cycle to Cycle Jitter	T <sub>CCJ</sub>	Measurement at 1.5 V	—	500	ps
Long Term Accuracy	L <sub>ACC</sub>	Measurement at 1.5 V	—	100	ppm
<b>ENABLE/DISABLE and SET-UP</b>					
Clock Stabilization from Powerup	T <sub>STABLE</sub>		—	1.8	ms
Stop clock Set-up Time	T <sub>SS</sub>		10.0	—	ns

**Table 4. Thermal Conditions**

Parameter	Symbol	Condition	Min	Max	Unit
Temperature, Storage	$T_S$	Non-functional	-65	150	°C
Temperature, Operating Ambient, Extended	$T_A$	Functional	-40	85	°C
Temperature, Operating Ambient, Commercial	$T_A$	Functional	0	70	°C
Temperature, Junction	$T_J$	Functional	—	150	°C
Dissipation, Junction to Case	$\theta_{JC}$	JEDEC (JESD 51)	—	20	°C/W
Dissipation, Junction to Ambient	$\theta_{JA}$	JEDEC (JESD 51)	—	60	°C/W

**Note:** For multiple supplies, the voltage on any input or I/O pin cannot exceed the power pin during powerup. Power supply sequencing is not required.

**Table 5. Absolute Maximum Conditions**

Parameter	Symbol	Test Condition	Min	Max	Unit
Main Supply Voltage	$V_{DD\_3.3V}$	Functional	—	4.6	V
Input Voltage	$V_{IN}$	Relative to $V_{SS}$	-0.5	4.6	$V_{DC}$
Temperature, Storage	$T_S$	Non-functional	-65	150	°C
Temperature, Operating Ambient	$T_A$	Functional	-40	85	°C
Temperature, Junction	$T_J$	Functional	—	150	°C
Dissipation, Junction to Case	$\theta_{JC}$	JEDEC (JESD 51)	—	20	°C/W
Dissipation, Junction to Ambient	$\theta_{JA}$	JEDEC (JESD 51)	—	60	°C/W
ESD Protection (Human Body Model)	$ESD_{HBM}$	JEDEC (JESD 22 - A114)	2000	—	V
Flammability Rating	UL-94	UL (Class)	V-0		
Moisture Sensitivity Level	MSL	JEDEC (J-STD-020)	1		

**Multiple Supplies:** The Voltage on any input or I/O pin cannot exceed the power pin during power-up. Power supply sequencing is NOT required.

## 2. Functional Description

### 2.1. Powerdown (PD#) Clarification

The CKPWRGD/PD# pin is a dual-function pin. During initial powerup, the pin functions as CKPWRGD. Once CKPWRGD has been sampled high by the clock chip, the pin assumes PD# functionality. The PD# pin is an asynchronous active low input used to shut off all clocks cleanly before shutting off power to the device. This signal is synchronized internally to the device before powering down the clock synthesizer. PD# is also an asynchronous input for powering up the system. When PD# is asserted low, clocks are driven to a low value and held before turning off the VCOs and the crystal oscillator.

### 2.2. Powerdown (PD#) Assertion

When PD# is sampled low by two consecutive rising edges of CPU\_C, all single-ended outputs clocks will be held low on their next high-to-low transition and differential clocks will be held low. When powerdown mode is desired as the initial power on state, PD# must be asserted low in less than 10  $\mu$ s after asserting CKPWRGD.

**Table 6. Output Driver Status during CPU\_STP# and PCIS\_STP#**

		<b>CPU_STP# Asserted</b>	<b>PCI_STP# Asserted</b>	<b>CLKREQ# Asserted</b>	<b>SMBus OE Disabled</b>
Single-ended Clocks	Stoppable	Running	Driven low	Running	Driven low
	Non-stoppable	Running	Running	Running	
Differential Clocks	Stoppable	Clock driven high	Clock driven high	Clock driven low	Clock driven low
		Clock driven low	Clock driven low	Clock driven low	
	Non-stoppable	Running	Running	Running	

**Table 7. Output Driver Status**

	<b>All Single-ended Clocks</b>		<b>All Differential Clocks</b>	
	<b>w/o Strap</b>	<b>w/ Strap</b>	<b>Clock</b>	<b>Clock#</b>
PD# = 0 (Powerdown)	Low	Hi-z	Low	Low

## 2.3. Powerdown (PD#) Deassertion

The powerup latency is less than 1.8 ms. This is the time from the deassertion of the PD# pin or the ramping of the power supply until the time that stable clocks are generated from the clock chip. All differential outputs stopped in a three-state condition resulting from powerdown are driven high in less than 300  $\mu$ s of PD# deassertion to a voltage greater than 200 mV. After the clock chip's internal PLL is powered up and locked, all outputs are enabled within a few clock cycles. Figure 2 is an example showing the relationship of clocks coming up.

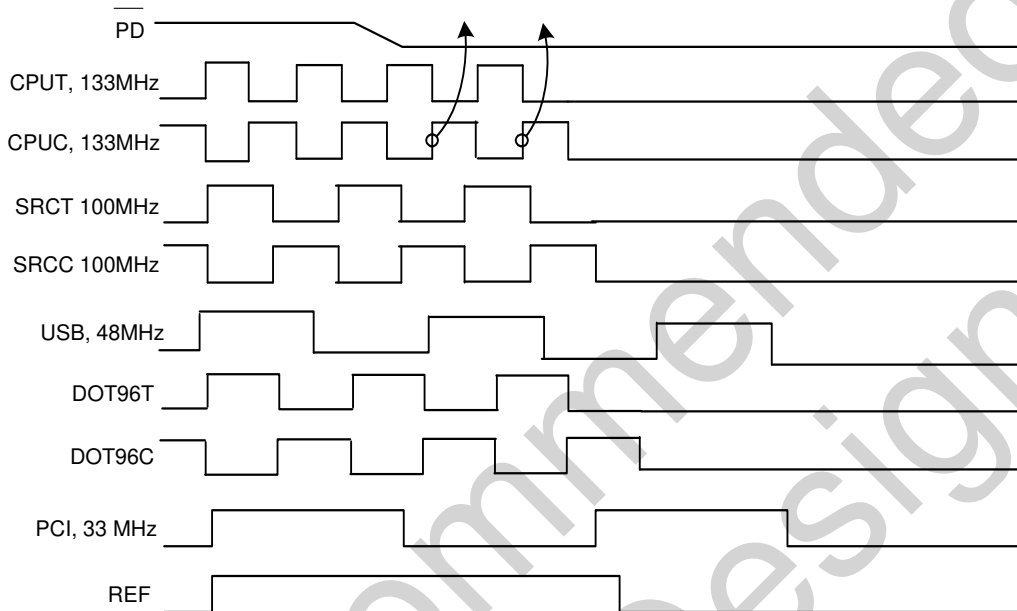

**Figure 1. Powerdown Assertion Timing Waveform**

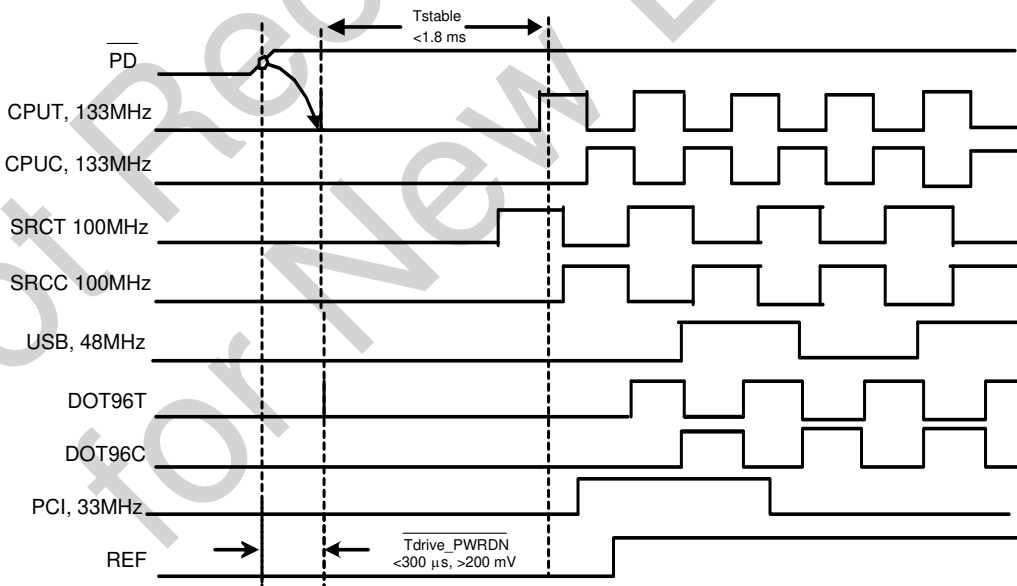

**Figure 2. Powerdown Deassertion Timing Waveform**

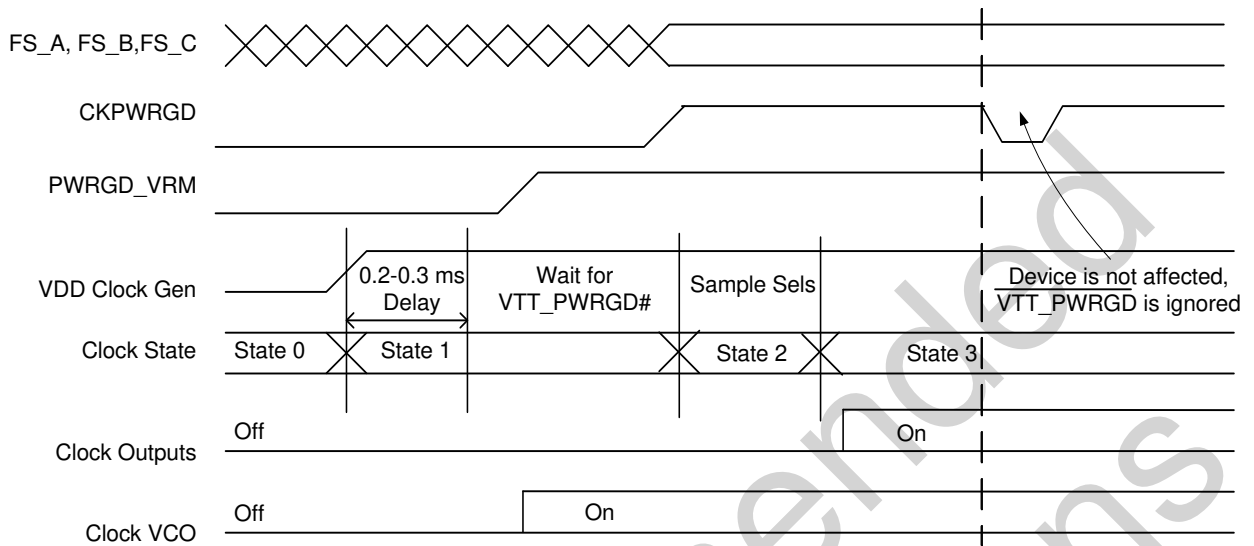

Figure 3. CKPWRGD Timing Diagram

Not Recommended for New Designs

## 2.4. CPU\_STP# Assertion

The CPU\_STP# signal is an active LOW input used for synchronous stopping and starting the CPU output clocks while the rest of the clock generator continues to function. When the CPU\_STP# pin is asserted, all CPU outputs that are set with the I<sup>2</sup>C configuration to be stoppable are stopped within two to six CPU clock periods after being sampled by two rising edges of the internal CPUC clock. The final states of the stopped CPU signals are CPUT = High and CPUC = Low.

## 2.5. CPU\_STP# Deassertion

The deassertion of the CPU\_STP# signal causes all stopped CPU outputs to resume normal operation in a synchronous manner. No short or stretched clock pulses are produced when the clock resumes. The maximum latency from the deassertion to active outputs is no more than two CPU clock cycles.

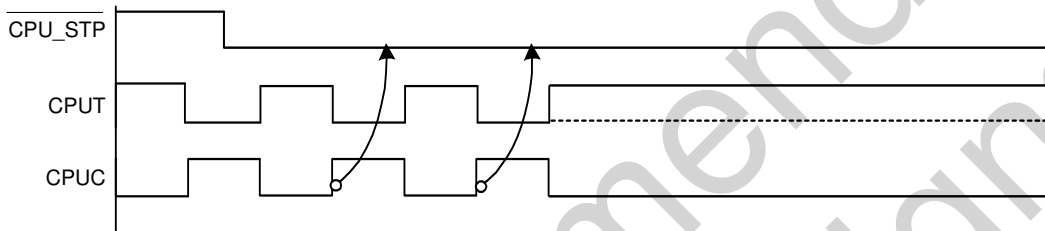

Figure 4. CPU\_STP# Assertion Waveform

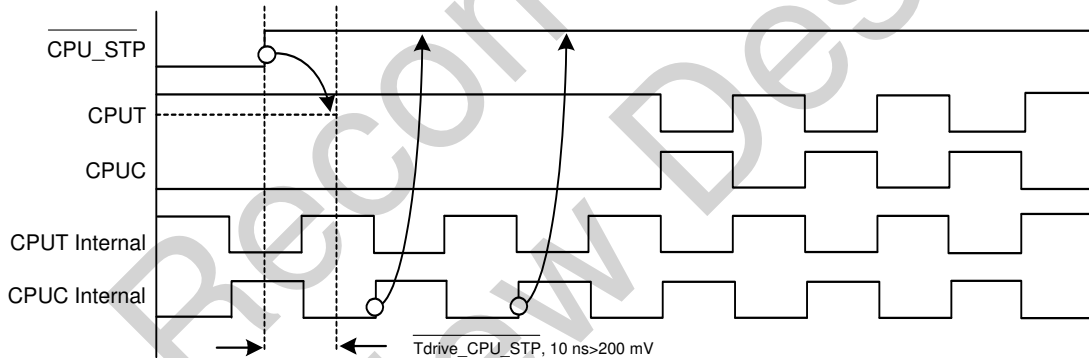

Figure 5. CPU\_STP# Deassertion Waveform

## 2.6. PCI/SRC\_STP# Assertion

The PCI/SRC\_STP# signal is an active low input used for synchronously stopping and starting the PCI outputs while the rest of the clock generator continues to function. The set-up time for capturing PCI/SRC\_STP# going low is 10 ns ( $t_{SU}$ ) (refer to Figure 6). The PCIF and SRC clocks are affected by the PCI/SRC pin if their corresponding control bit in the I<sup>2</sup>C register is set to allow them to be free running. For SRC clocks assertion description, refer to the CPU\_STP# descriptions in Section 2.4 and Section 2.5.

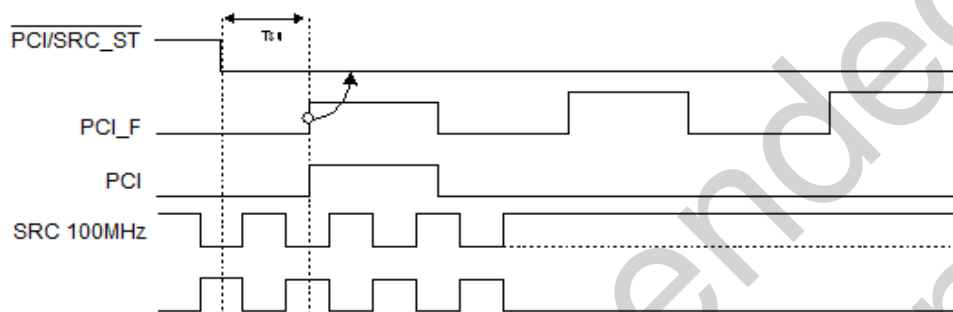

Figure 6. PCI/SRC\_STP# Assertion Waveform

## 2.7. PCI/SRC\_STP# Deassertion

The deassertion of the PCI/SRC\_STP# signal causes all PCI and stoppable PCIF to resume running in a synchronous manner within two PCI clock periods and after PCI/SRC\_STP# transitions to a high level. Similarly, PCI/SRC\_STP# deassertion will cause stoppable SRC clocks to resume running. For an SRC clocks deassertion description, refer to the CPU\_STP# description Section 2.4 and Section 2.5.

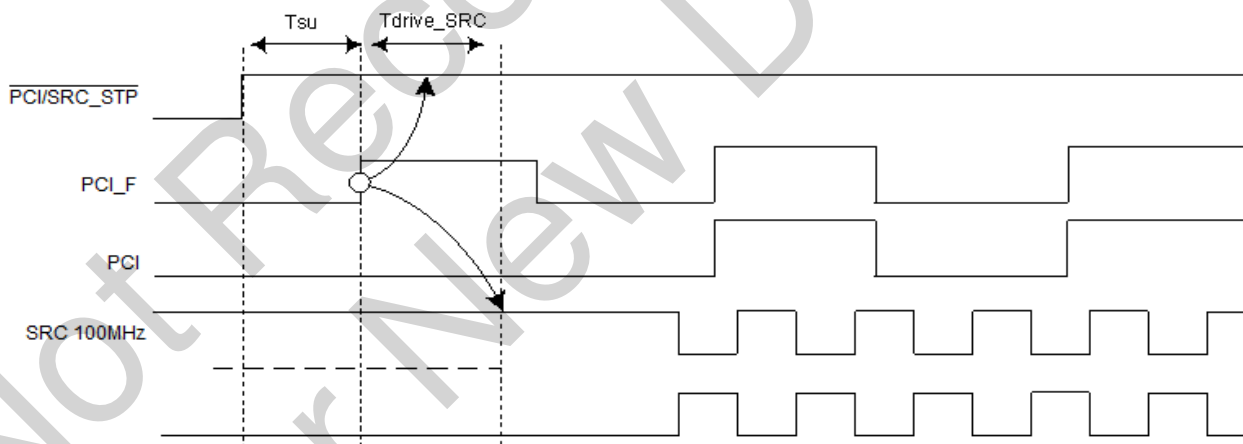

Figure 7. PCI/SRC\_STP# Deassertion Waveform

## 3. Test and Measurement Setup

### 3.1. Single-ended Clocks

Figure 8 shows the test load configuration for single-ended clock output signals.

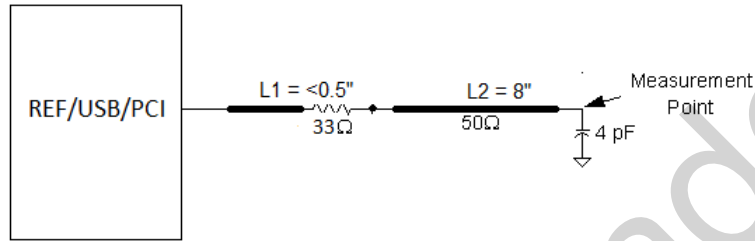

Figure 8. Single-ended Clocks Single Load Configuration

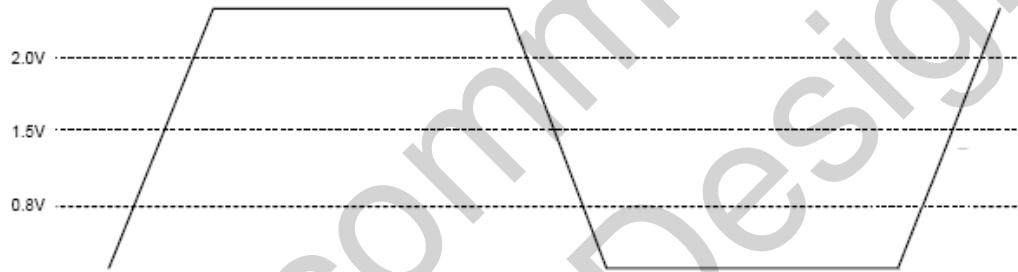

Figure 9. Single-ended Output Signals (for AC Parameters Measurement)

### 3.2. Differential Clock Signals

Figure 10 shows the test load configuration for differential clock signals.

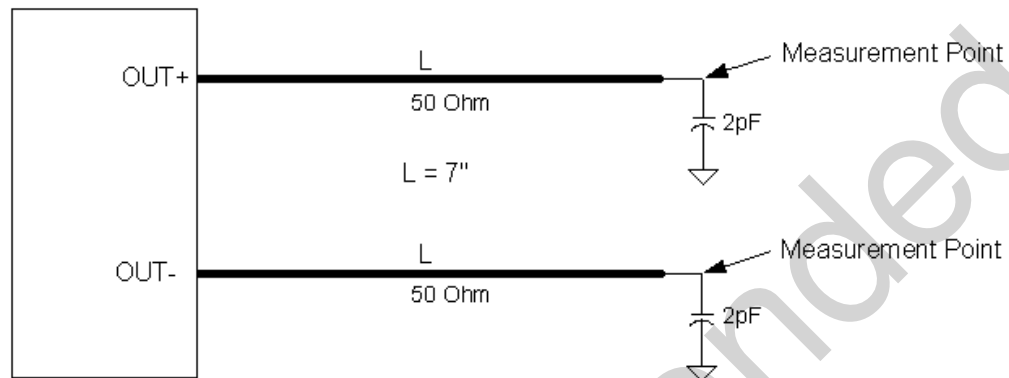

Figure 10. 0.7 V Differential Load Configuration

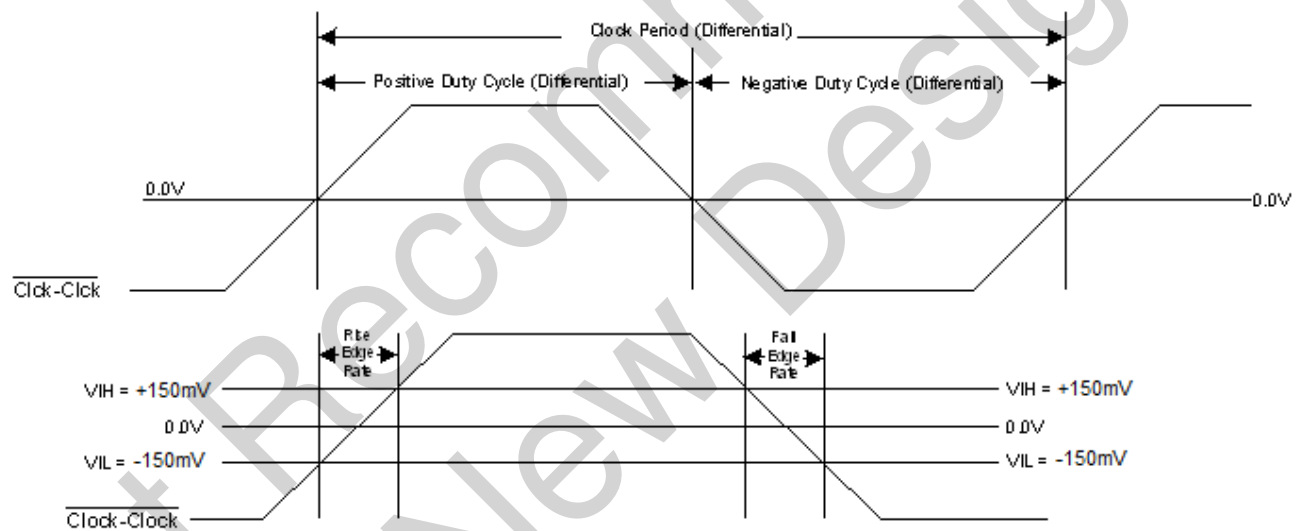

Figure 11. Differential Measurement for Differential Output Signals  
(for AC Parameters Measurement)

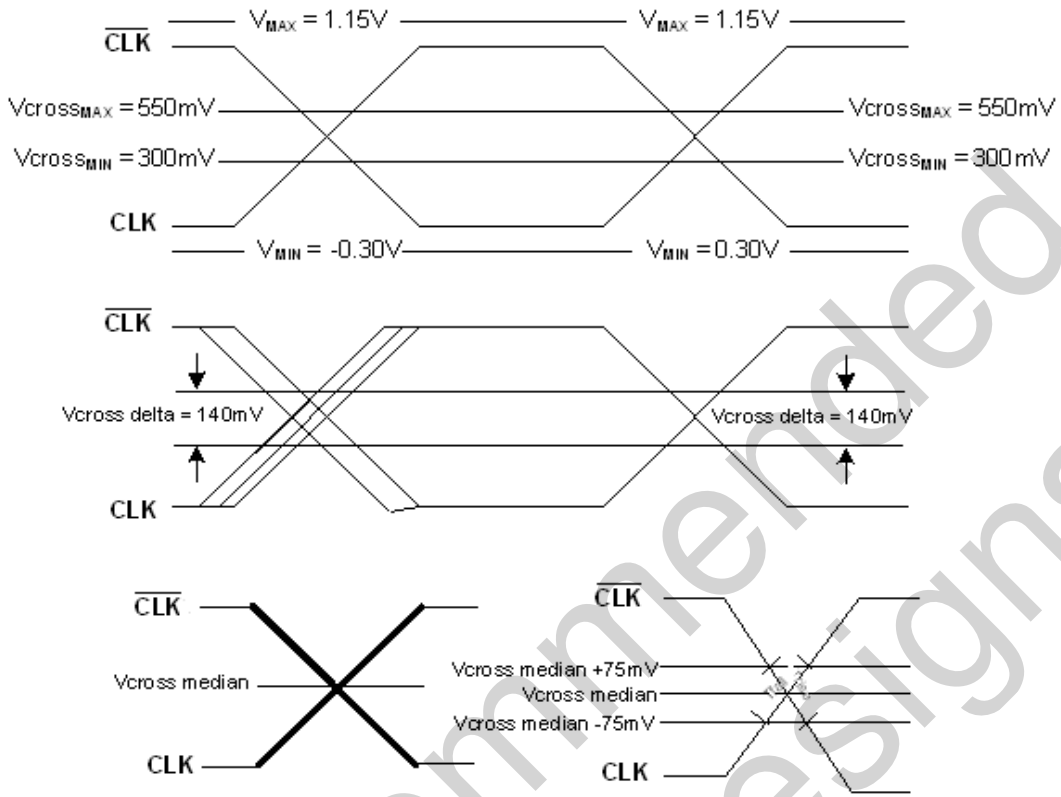

Figure 12. Single-ended Measurement for Differential Output Signals (for AC Parameters Measurement)

## 4. Control Registers

### 4.1. Frequency Select Pin FS

Apply the appropriate logic levels to FS inputs before CKPWRGD assertion to achieve host clock frequency selection. When the clock chip sampled HIGH on CKPWRGD and indicates that VTT voltage is stable then FS input values are sampled. This process employs a one-shot functionality and once the CKPWRGD sampled a valid HIGH, all other FS, and CKPWRGD transitions are ignored except in test mode.

**Table 8. Frequency Select Pin (FS)**

SEL_SATA	FSC	FSB	FSA	CPU	SRC	SATA	PCI
0	0	0	0	100.00	100.00	100.00	33.33
0	0	0	1	100.00	100.00	100.00	33.33
0	0	1	0	83.33	100.00	100.00	33.33
0	0	1	1	83.33	100.00	100.00	33.33
0	1	0	0	133.33	100.00	100.00	33.33
0	1	0	1	133.33	100.00	100.00	33.33
0	1	1	0	166.67	100.00	100.00	33.33
0	1	1	1	166.67	100.00	100.00	33.33
1	0	0	0	100.00	100.00	100.00	33.33
1	0	0	1	100.00	100.00	100.00	33.33
1	0	1	0	83.33	100.00	100.00	33.33
1	0	1	1	83.33	100.00	100.00	33.33
1	1	0	0	133.33	100.00	100.00	33.33
1	1	0	1	133.33	100.00	100.00	33.33
1	1	1	0	166.67	100.00	100.00	33.33
1	1	1	1	166.67	100.00	100.00	33.33

## 4.2. Serial Data Interface

To enhance the flexibility and function of the clock synthesizer, a two-signal serial interface is provided. Through the Serial Data Interface, various device functions, such as individual clock output buffers are individually enabled or disabled. The registers associated with the Serial Data Interface initialize to their default setting at power-up. The use of this interface is optional. Clock device register changes are normally made at system initialization, if any are required. The interface cannot be used during system operation for power management functions.

## 4.3. Data Protocol

The clock driver serial protocol accepts byte write, byte read, block write, and block read operations from the controller. For block write/read operation, access the bytes in sequential order from lowest to highest (most significant bit first) with the ability to stop after any complete byte is transferred. For byte write and byte read operations, the system controller can access individually indexed bytes. The offset of the indexed byte is encoded in the command code described in Table 9.

The block write and block read protocol is outlined in Table 10 while Table 11 outlines byte write and byte read protocol. The slave receiver address is 11010010 (D2h).

**Table 9. Command Code Definition**

Bit	Description
7	0 = Block read or block write operation; 1 = Byte read or byte write operation.
(6:0)	Byte offset for byte read or byte write operation. For block read or block write operations, these bits should be '0000000'.

**Table 10. Block Read and Block Write Protocol**

Block Write Protocol		Block Read Protocol	
Bit	Description	Bit	Description
1	Start	1	Start
8:2	Slave address–7 bits	8:2	Slave address–7 bits
9	Write	9	Write
10	Acknowledge from slave	10	Acknowledge from slave
18:11	Command Code–8 bits	18:11	Command Code–8 bits
19	Acknowledge from slave	19	Acknowledge from slave
27:20	Byte Count–8 bits	20	Repeat start
28	Acknowledge from slave	27:21	Slave address–7 bits
36:29	Data byte 1–8 bits	28	Read = 1
37	Acknowledge from slave	29	Acknowledge from slave
45:38	Data byte 2–8 bits	37:30	Byte Count from slave–8 bits
46	Acknowledge from slave	38	Acknowledge
....	Data Byte /Slave Acknowledges	46:39	Data byte 1 from slave–8 bits

Table 10. Block Read and Block Write Protocol (Continued)

Block Write Protocol		Block Read Protocol	
Bit	Description	Bit	Description
....	Data Byte N–8 bits	47	Acknowledge
....	Acknowledge from slave	55:48	Data byte 2 from slave–8 bits
....	Stop	56	Acknowledge
		....	Data bytes from slave / Acknowledge
		....	Data Byte N from slave–8 bits
		....	NOT Acknowledge
		....	Stop

Table 11. Byte Read and Byte Write Protocol

Byte Write Protocol		Byte Read Protocol	
Bit	Description	Bit	Description
1	Start	1	Start
8:2	Slave address–7 bits	8:2	Slave address–7 bits
9	Write	9	Write
10	Acknowledge from slave	10	Acknowledge from slave
18:11	Command Code–8 bits	18:11	Command Code–8 bits
19	Acknowledge from slave	19	Acknowledge from slave
27:20	Data byte–8 bits	20	Repeated start
28	Acknowledge from slave	27:21	Slave address–7 bits
29	Stop	28	Read
		29	Acknowledge from slave
		37:30	Data from slave–8 bits
		38	NOT Acknowledge
		39	Stop

# SL28EB742

## Control Register 0. Byte 0

Bit	D7	D6	D5	D4	D3	D2	D1	D0
Name			Spread Enable	SEL_SATA		FSC	FSB	FSA
Type	R/W	R/W	R/W	R	R/W	R	R	R

Reset settings = 000x0xxx

Bit	Name	Function
7:6	Reserved	
5	Spread Enable	Enable spread for CPU/SRC/PCI outputs 0 = Disable, 1 = -0.5%
4	SEL_SATA	See Table 9 for SATA/SRC selection.
3	Reserved	
2	FSC	See Table 9 for CPU Frequency Selection Table.
1	FSB	
0	FSA	

## Register 1. Byte 1

Bit	D7	D6	D5	D4	D3	D2	D1	D0
Name	DOT96_OE	SATA/SRC0_OE	CPU2/SRC6_OE	SRC2	SRC1		WOL_EN	
Type	R/W	R/W	R/W	R/W	R/W	R/W	R/W	R/W

Reset settings = 1111110

Bit	Name	Function
7	DOT96_OE	<b>Output enable for DOT96.</b> 0 = Output Disabled, 1 = Output Enabled
6	SATA/SRC0_OE	<b>Output enable for SATA/SRC0.</b> 0 = Output Disabled, 1 = Output Enabled
5	CPU2/SRC6_OE	<b>Output enable for CPU2/SRC6.</b> 0 = Output Disabled, 1 = Output Enabled
4	SRC2	<b>Output enable for SRC2.</b> 0 = Output Disabled, 1 = Output Enabled
3	SRC1	<b>Output enable for SRC1.</b> 0 = Output Disabled, 1 = Output Enabled
2	Reserved	
1	WOL_EN	<b>Wake-On-LAN Enable bit.</b> 25 MHz free running during VDD Suspend (S-states). If this bit is set to 0, the XTAL OSC will also be powered down in the Suspend States)
0	Reserved	

# SL28EB742

## Register 2. Byte 2

Bit	D7	D6	D5	D4	D3	D2	D1	D0
Name	48M_OE		25M_OE	REF_OE	12_48M_OE	PCI0_OE	PCIF_OE	
Type	R/W	R/W	R/W	R/W	R/W	R/W	R/W	R/W

Reset settings = 10111110

Bit	Name	Function
7	48M_OE	<b>Output Enable for 48M.</b> 0: Output disabled. 1: Output enabled.
6	Reserved	
5	25M_OE	<b>Output ENABLE for 25M.</b> 0 = Output Disabled, 1 = Output Enabled
4	REF_OE	<b>Output Enable for REF.</b> 0 = Output Disabled, 1 = Output Enabled
3	12_48M_OE	<b>Output Enable for 12_48M.</b> 0 = Output Disabled, 1 = Output Enabled
2	PCI0_OE	<b>Output Enable for PCI0.</b> 0 = Output Disabled, 1 = Output Enabled
1	PCIF_OE	<b>Output Enable for PCIF.</b> 0 = Output Disabled, 1 = Output Enabled
0	Reserved	

## Register 3. Byte 3

Bit	D7	D6	D5	D4	D3	D2	D1	D0
Name	CPU1_OE	CPU0_OE	CLKREQ#_3	CLKREQ#_3	CLKREQ#_2	CLKREQ#_2	CLKREQ#_1	CLKREQ#_1
Type	R/W	R/W	R/W	R/W	R/W	R/W	R/W	R/W

Reset settings = 1100000

Bit	Name	Function
7	CPU1_OE	<b>Output Enable for CPU1.</b> 0 = Output Disabled, 1 = Output Enabled
6	CPU0_OE	<b>Output Enable for CPU0.</b> 0 = Output Disabled, 1 = Output Enabled
5	CLKREQ#_3	<b>Clock Request for SRC2.</b> 0 = Not controlled, 1 = Controlled
4	CLKREQ#_3	<b>Clock Request for SRC6 (does not apply to CPU clock).</b> 0 = Not controlled, 1 = Controlled
3	CLKREQ#_2	<b>Clock Request for SRC2.</b> 0 = Not controlled, 1 = Controlled
2	CLKREQ#_2	<b>Clock Request for SATA75M/SRC0.</b> 0 = Not controlled, 1 = Controlled
1	CLKREQ#_1	<b>Clock Request for SRC1.</b> 0 = Not controlled, 1 = Controlled
0	CLKREQ#_1	<b>Clock Request for SATA75M/SRC0.</b> 0 = Not controlled, 1 = Controlled