



Chipsmall Limited consists of a professional team with an average of over 10 year of expertise in the distribution of electronic components. Based in Hongkong, we have already established firm and mutual-benefit business relationships with customers from,Europe,America and south Asia,supplying obsolete and hard-to-find components to meet their specific needs.

With the principle of “Quality Parts,Customers Priority,Honest Operation,and Considerate Service”,our business mainly focus on the distribution of electronic components. Line cards we deal with include Microchip,ALPS,ROHM,Xilinx,Pulse,ON,Everlight and Freescale. Main products comprise IC,Modules,Potentiometer,IC Socket,Relay,Connector.Our parts cover such applications as commercial,industrial, and automotives areas.

We are looking forward to setting up business relationship with you and hope to provide you with the best service and solution. Let us make a better world for our industry!



## Contact us

Tel: +86-755-8981 8866 Fax: +86-755-8427 6832

Email & Skype: info@chipsmall.com Web: www.chipsmall.com

Address: A1208, Overseas Decoration Building, #122 Zhenhua RD., Futian, Shenzhen, China



# SL3S1003\_1013

## UCODE G2iM and G2iM+

Rev. 3.7 — 21 May 2015  
201237

Product data sheet  
COMPANY PUBLIC

## 1. General description

---

NXP's UCODE G2iM series transponder ICs offers in addition to the leading-edge read range features such as a Tag Tamper Alarm, Data Transfer, Digital Switch, advanced privacy-protection modes and a 640 bit configurable User Memory.

Very high chip sensitivity ( $-17.5$  dBm) enables longer read ranges with simple, single-port antenna designs. In fashion and retail the UCODE G2iM series improve read rates and provide for theft deterrence. In the electronic device market, they are ideally suited for device configuration, activation, production control and PCB tagging. In authentication applications, they protect brands and guard against counterfeiting. They can also be used to tag containers, electronic vehicles, airline baggage, and more.

In addition to the EPC specifications the UCODE G2iM offers an integrated Product Status Flag (PSF) feature and read protection of the memory content.

The UCODE G2iM+ offers on top of the UCODE G2iM features an integrated tag tamper alarm, digital switch, external supply mode, data transfer mode and real read range reduction. A special feature is the conditional, automatic real read range reduction, where the activation condition can be defined by the user, is newly introduced in the UCODE G2iM+. When connected to a power supply, the READ as well as the WRITE range can be boosted to a sensitivity of  $-27$  dBm.

The UCODE G2iM+ also allows the segmentation of the 640 bit User Memory in up to three segments (open, protected, private) with different access levels (Access- and User Password). For applications which require a longer EPC number the UCODE G2iM+ offers the possibility of up to 448 bit.

## 2. Features and benefits

---

### 2.1 Key features

- UHF RFID Gen2 tag chip according EPCglobal v1.2.0
- 256 bit EPC for UCODE G2iM and up to 448 bit EPC for UCODE G2iM+
- Up to 640 bit User Memory which can be segmented in the UCODE G2iM+
- Private User Memory area protected by special User Password
- Memory read protection
- Integrated Product Status Flag (PSF)
- Tag tamper alarm
- Digital switch
- Data transfer mode



- Real Read Range Reduction (Privacy Mode)
- Conditional Real Read Range Reduction
- External supply mode
- Long read/write ranges due to extremely low power design
- Reliable operation of multiple tags due to advanced anti-collision
- Broad international operating frequency: from 840 MHz to 960 MHz
- Data retention: 20 years
- Wide specified temperature range: -40 °C up to +85 °C

### 2.1.1 Memory

- 256 bit of EPC memory / up to 448 bit in G2iM+
- 96 bit Tag IDentifier (TID) including 48-bit factory locked unique serial number
- 112 bit User TID memory
- 32 bit Kill Password to permanently disable the tag
- 32 bit Access Password to allow a transition into the secured state
- 32 bit User Password to allow access to the private user memory segment
- Read protection
- BlockWrite (32 bit)
- Write Lock
- BlockPermalock

## 2.2 Key benefits

### 2.2.1 End user benefit

- Outstanding User Memory size of 640 bit
- Prevention of unauthorized memory access through different levels of read protection
- Indication of tag tampering attempt by use of the tag tamper alarm feature
- Electronic device configuration and / or activation by the use of the digital switch / data transfer mode
- Theft deterrence supported by the PSF feature (PSF alarm or EPC code)
- Small label sizes, long read ranges due to high chip sensitivity
- Product identification through unalterable TID range, including a 48 bit serial number
- Reliable operation in dense reader and noisy environments through high interference suppression

### 2.2.2 Antenna design benefits

- High sensitivity enables small and cost efficient antenna designs
- Low Q-Value eases broad band antenna design for global usage

### 2.2.3 Label manufacturer benefit

- Consistent performance on different materials due to low Q-factor
- Ease of assembly and high assembly yields through large chip input capacitance and Polyimide spacer
- Fast first WRITE or BLOCKWRITE of the EPC memory for fast label initialization

## 2.3 Custom commands

- PSF Alarm  
Built-in PSF (Product Status Flag), enables the UHF RFID tag to be used as EAS tag (Electronic Article Surveillance) tag without the need for a back-end data base.
- Read Protect  
Protects all memory content from unauthorized reading.
- ChangeConfig  
Configures the additional features of the chip like external supply mode, tamper alarm, digital switch, read range reduction, privacy mode activation condition or data transfer.

The UCODE G2iM+ is equipped with a number of additional features. Nevertheless, the chip is designed in a way standard EPCglobal READ/WRITE/ACCESS commands can be used to operate the features. No custom commands are needed to take advantage of all the features in case of unlocked EPC memory.

## 3. Applications

### 3.1 Markets

- Fashion (apparel and footwear)
- Retail
- Electronics
- Fast moving consumer goods
- Asset management
- Electronic vehicle identification

### 3.2 Applications

- Supply chain management
  - ◆ Item level tagging
  - ◆ Pallet and case tracking
- Container identification
- Product authentication
- PCB tagging
- Cost efficient, low level seals
- Wireless firmware download
- Wireless product activation

## 4. Ordering information

Table 1. Ordering information

Type number	Package		Description	Version
	Name	IC type		
SL3S1003FUD/BG	Wafer	G2iM	bumped G2iM die on sawn 8" 120 mm wafer, 7 mm Polyimide spacer	not applicable
SL3S1013FUD/BG	Wafer	G2iM+	bumped G2iM+ die on sawn 8" 120 mm wafer, 7 mm Polyimide spacer	not applicable
SL3S1013FTB0	XSON6	G2iM+	plastic extremely thin small outline package; no leads; 6 terminals; body 1 × 1.45 × 0.5 mm	SOT886F1

## 5. Marking

Table 2. Marking codes

Type number	Marking code	Comment	Version
SL3S1013FTB0	US	UCODE G2iM+	SOT886

## 6. Block diagram

The SL3S10x3 IC consists of three major blocks:

- Analog Interface
- Digital Control
- EEPROM

The analog part provides stable supply voltage and demodulates data received from the reader for being processed by the digital part. Further, the modulation transistor of the analog part transmits data back to the reader.

The digital section includes the state machines, processes the protocol and handles communication with the EEPROM, which contains the EPC and the user data.

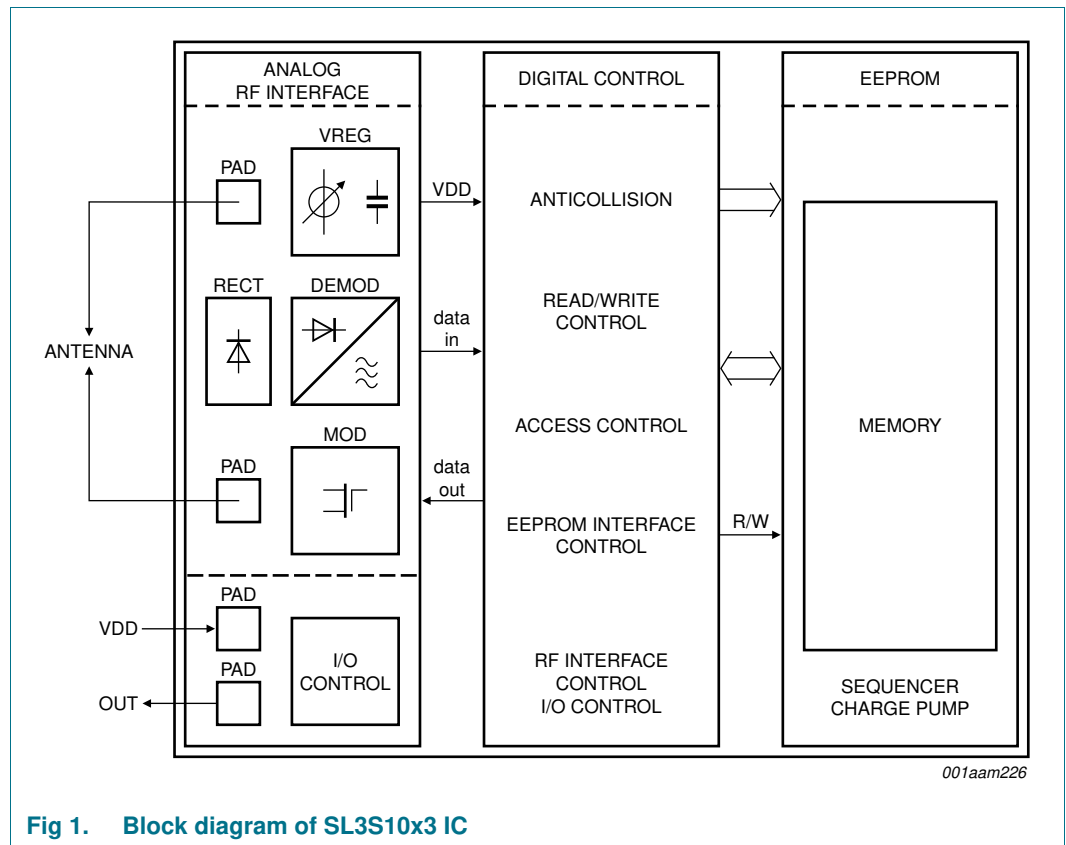
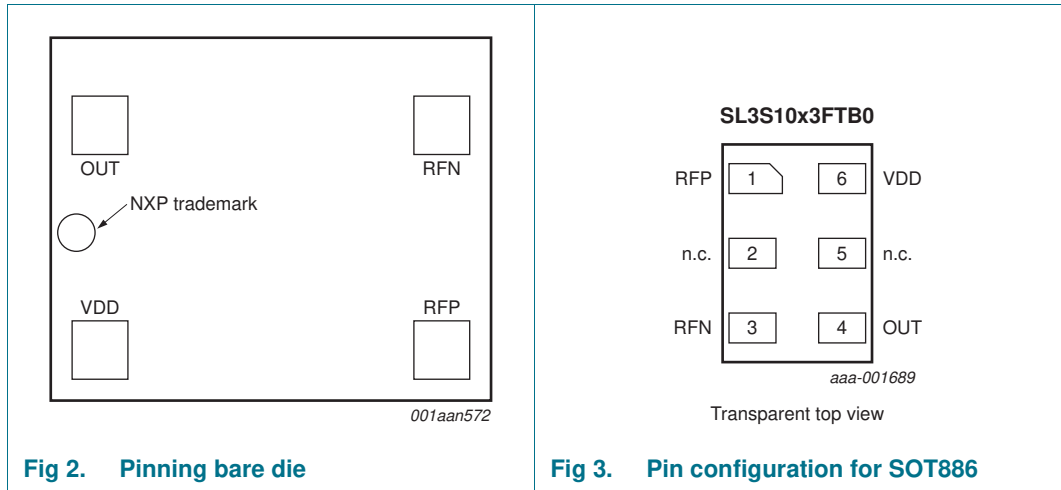

Fig 1. Block diagram of SL3S10x3 IC

## 7. Pinning information



### 7.1 Pin description

Table 3. Pin description bare die

Symbol	Description
OUT	output pin
RFN	grounded antenna connector
VDD	external supply
RFP	ungrounded antenna connector

Table 4. Pin description SOT886

Pin	Symbol	Description
1	RFP	ungrounded antenna connector
2	n.c.	not connected
3	RFN	grounded antenna connector
4	OUT	output pin
5	n.c.	not connected
6	VDD	external supply

## 8. Wafer layout

### 8.1 Wafer layout

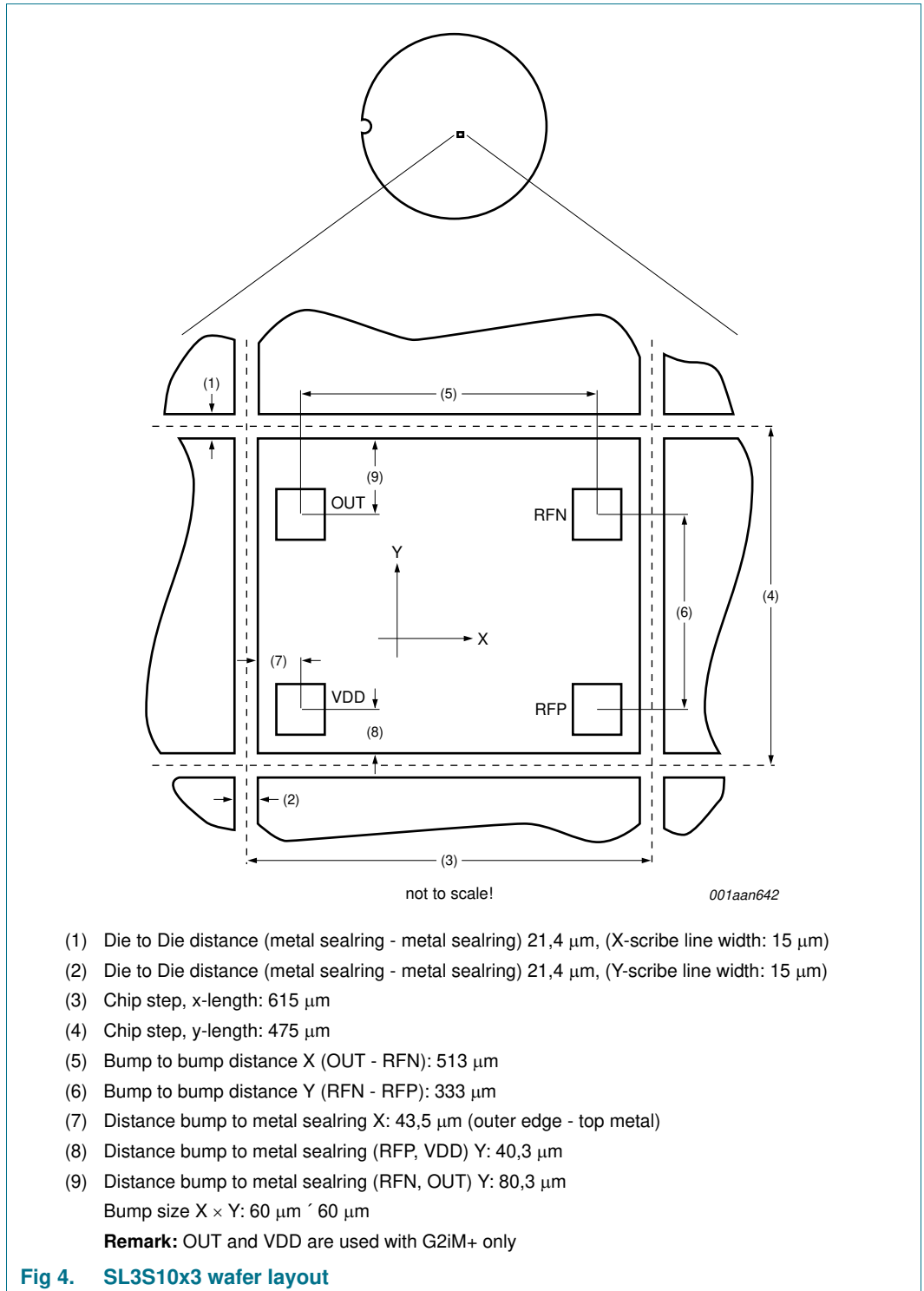



## 9. Mechanical specification

The SL3S10x3 wafers are offered with 120 mm thickness and 7mm Polyimide spacer. This robust structure with the enhanced Polyimide spacer supports easy assembly due to low assembly variations.

### 9.1 Wafer specification

See [Ref. 20 "Data sheet - Delivery type description – General specification for 8" wafer on UV-tape with electronic fail die marking, BU-ID document number: 1093\\*\\*"](#).

#### 9.1.1 Wafer

**Table 5. Specifications**

Wafer	
Designation	each wafer is scribed with batch number and wafer number
Diameter	200 mm (8")
Thickness	120 $\mu\text{m}$ $\pm$ 15 $\mu\text{m}$
Number of pads	4
Pad location	non diagonal/ placed in chip corners
Distance pad to pad RFN-RFP	333.0 $\mu\text{m}$
Distance pad to pad OUT-RFN	513.0 $\mu\text{m}$
Process	CMOS 0.14 $\mu\text{m}$
Batch size	25 wafers
Potential good dies per wafer	100544
Wafer backside	
Material	Si
Treatment	ground and stress release
Roughness	$R_a$ max. 0.5 $\mu\text{m}$ , $R_t$ max. 5 $\mu\text{m}$
Chip dimensions	
Die size including scribe	0.615 mm $\times$ 0.475 mm = 0.292 mm <sup>2</sup>
Scribe line width:	x-dimension = 15 $\mu\text{m}$
	y-dimension = 15 $\mu\text{m}$
Passivation on front	
Type	Sandwich structure
Material	PE-Nitride (on top)
Thickness	1.75 $\mu\text{m}$ total thickness of passivation
Polyimide spacer	7 $\mu\text{m}$
Au bump	
Bump material	> 99.9% pure Au
Bump hardness	35 – 80 HV 0.005
Bump shear strength	> 70 MPa
Bump height	25 $\mu\text{m}$ <a href="#">[1]</a>
Bump height uniformity	

**Table 5. Specifications ...continued**

– within a die	$\pm 2 \mu\text{m}$
– within a wafer	$\pm 3 \mu\text{m}$
– wafer to wafer	$\pm 4 \mu\text{m}$
Bump flatness	$\pm 1.5 \mu\text{m}$
Bump size	
– RFP, RFN	$60 \times 60 \mu\text{m}$
– OUT, VDD	$60 \times 60 \mu\text{m}$
Bump size variation	$\pm 5 \mu\text{m}$

[1] Because of the  $7 \mu\text{m}$  spacer, the bump will measure  $18 \mu\text{m}$  relative height protruding the spacer.

### 9.1.2 Fail die identification

No inkdots are applied to the wafer.

Electronic wafer mapping (SECS II format) covers the electrical test results and additionally the results of mechanical/visual inspection.

See [Ref. 20 “Data sheet - Delivery type description – General specification for 8” wafer on UV-tape with electronic fail die marking, BU-ID document number: 1093\\*\\*”](#)

### 9.1.3 Map file distribution

See [Ref. 20 “Data sheet - Delivery type description – General specification for 8” wafer on UV-tape with electronic fail die marking, BU-ID document number: 1093\\*\\*”](#)

## 10. Functional description

### 10.1 Air interface standards

The UCODE G2iM fully supports all parts of the "Specification for RFID Air Interface EPCglobal, EPCTM Radio-Frequency Identity Protocols, Class-1 Generation-2 UHF RFID, Protocol for Communications at 860 MHz to 960 MHz, Version 1.2.0".

### 10.2 Power transfer

The interrogator provides an RF field that powers the tag, equipped with a UCODE G2iM. The antenna transforms the impedance of free space to the chip input impedance in order to get the maximum possible power for the UCODE G2iM on the tag. The UCODE G2iM+ can also be supplied externally.

The RF field, which is oscillating on the operating frequency provided by the interrogator, is rectified to provide a smoothed DC voltage to the analog and digital modules of the IC.

The antenna attached to the chip may use a DC connection between the two antenna pads which also enables loop antenna design.

### 10.3 Data transfer

#### 10.3.1 Reader to tag Link

An interrogator transmits information to the UCODE G2iM by modulating an UHF RF signal. The UCODE G2iM receives both information and operating energy from this RF signal. Tags are passive, meaning that they receive all of their operating energy from the interrogator's RF waveform. In order to further improve the read range the UCODE G2iM can be externally supplied as well so the energy to operate the chip does not need to be transmitted by the reader.

An interrogator is using a fixed modulation and data rate for the duration of at least one inventory round. It communicates to the UCODE G2iM by modulating an RF carrier using DSB-ASK with PIE encoding.

For further details refer to [Section 17](#), [Ref. 1](#). Interrogator-to-tag (R=>T) communications.

#### 10.3.2 Tag to reader Link

An interrogator receives information from a UCODE G2iM by transmitting an unmodulated RF carrier and listening for a backscattered reply. The UCODE G2iM backscatters by switching the reflection coefficient of its antenna between two states in accordance with the data being sent. For further details refer to [Section 17](#), [Ref. 1](#), chapter 6.3.1.3.

The UCODE G2iM communicates information by backscatter-modulating the amplitude and/or phase of the RF carrier. Interrogators shall be capable of demodulating either demodulation type.

The encoding format, selected in response to interrogator commands, is either FM0 baseband or Miller-modulated subcarrier.

## 10.4 UCODE G2iM and UCODE G2iM+ differences

The UCODE G2iM is tailored for application where EPC or TID number space, and User Memory is needed. The UCODE G2iM+ provides beside the segmented memory additional functionality such as tag tamper alarm, external supply operation to further boost read/write range (external supply mode), a privacy mode reducing the read range where the activation criteria (open or short) can be defined or I/O functionality (data transfer to externally connected devices) where required.

The following table provides an overview of UCODE G2iM, UCODE G2iM+ special features.

**Table 6. Overview of UCODE G2iM and UCODE G2iM+ features**

Features	UCODE G2iM	UCODE G2iM+
Read protection (bankwise)	yes	yes
PSF (Built-in Product Status Flag)	yes	yes
Backscatter strength reduction	yes	yes
BlockWrite (32 bit)	yes	yes
BlockPermalock	yes	yes
User TID (112 bit)	yes	yes
Segmented user memory (open, protected, private)	-	yes
Additional User Password for private memory	-	yes
EPC size selectable (448bit max.)	-	yes
Tag tamper alarm	-	yes
Digital switch / Digital input	-	yes
External supply mode	-	yes
Data transfer	-	yes
Real read range reduction	-	yes
Conditional Real Read Range Reduction	-	yes

## 10.5 Supported commands

The UCODE G2iM supports all **mandatory** EPCglobal V1.2.0 commands.

In addition the UCODE G2iM supports the following **optional** commands:

- ACCESS
- BlockWrite (32 bit)
- BlockPermalock

The UCODE G2iM features the following **custom** commands described more in detail later:

- ResetReadProtect (backward compatible to UCODE G2X; UCODE G2iL)
- ReadProtect(backward compatible to UCODE G2X; UCODE G2iL)
- ChangeEAS (backward compatible to UCODE G2X; UCODE G2iL)
- EAS\_Alarm(backward compatible to UCODE G2X; UCODE G2iL)
- ChangeConfig(backward compatible to UCODE G2iL)

**10.6 UCODE G2iM and UCODE G2iM+ memory**

The UCODE G2iM and UCODE G2iM+ memory is implemented according EPCglobal Class1Gen2 and organized in four banks:

**Table 7. UCODE G2iM and UCODE G2iM+ memory sections**

Name	Size	Bank
Reserved memory (32 bit ACCESS and 32 bit KILL password)	64 bit	00b
EPC (excluding 16 bit CRC-16 and 16 bit PC) (UCODE G2iM)	256 bit	01b
EPC (excluding 16 bit CRC-16 and 16 bit PC) (UCODE G2iM+)	128 bit up to 448 bit	
G2iM Configuration Word (Config-Word)	16 bit	01b
G2iM Memory Configuration Word (Mem-Config-Word)	16 bit	01b
TID (including permalocked unique 48 bit serial number; 16bit unalterable XTID-header)	96 bit	10b
User TID	112 bit	10b
User memory (UCODE G2iM)	512 bit	11b
User memory can be segmented and configured (UCODE G2iM+)	320 bit up to 640 bit	

The logical address of all memory banks begin at zero (00h).

In addition to the four memory banks two configuration words are available. The first to handle the UCODE G2iM memory configuration (Mem-Config-Word) is available at EPC bank 01 address 1F0h and the second to handle UCODE G2iM specific features (Config-Word) is available at EPC bank 01 address 200h. The configuration words are described in detail in [Section 10.7.1 “ChangeConfig”](#) and [Section 10.7.3 “UCODE G2iM+ memory configuration control mechanism”](#).

Memory pages (16 bit words) pre-programmed to zero will not execute an erase cycle before writing data to it. This approach accelerates initialization of the chip and enables faster programming of the memory.

## 10.6.1 UCODE G2iM and UCODE G2iM+ overall memory map

Table 8. UCODE G2iM and UCODE G2iM+ overall memory map

Bank address	Memory address	Type	Content	Initial	Remark
Bank 00	00h to 1Fh	reserved	Kill Password	all 00h	unlocked memory
	20h to 3Fh	reserved	Access Password	all 00h	unlocked memory
Bank 01 EPC	00h to 0Fh	EPC	CRC-16: refer to <a href="#">Ref. 16</a>		memory mapped calculated CRC
	10h to 14h	EPC	backscatter length	00110b	unlocked memory
	15h	EPC	UMI	0b	calculated according EPC
	16h	EPC	reserved for future use	0b	hardwired to 0
	17h to 1Fh	EPC	numbering system indicator	00h	unlocked memory
	20h to 9Fh	EPC	EPC	<a href="#">[1]</a>	unlocked memory
Bank 01 Memory Config Word	1F0h to 1F3h	EPC	RFU	0000b	hardwired to 0000b
	1F4h to 1F7h	EPC	Number of EPC blocks	0h	unlocked memory
	1F8h to 1FBh	EPC	Number protected memory blocks	0h	unlocked memory
	1FCh to 1FFh	EPC	Number of private memory blocks	0h	unlocked memory
Bank 01 Config Word	200h	EPC	tamper alarm flag	0b <a href="#">[4]</a>	indicator bit
	201h	EPC	external supply flag or input signal	0b <a href="#">[4]</a>	indicator bit
	202h	EPC	RFU	0b <a href="#">[4]</a>	locked memory
	203h	EPC	RFU	0b <a href="#">[4]</a>	locked memory
	204h	EPC	invert digital output:	0b <a href="#">[4]</a>	temporary bit
	205h	EPC	transparent mode on/off	0b <a href="#">[4]</a>	temporary bit
	206h	EPC	transparent mode data/raw	0b <a href="#">[4]</a>	temporary bit
	207h	EPC	conditional read range reduction	0b <a href="#">[4]</a>	unlocked memory
	208h	EPC	conditional read range reduction open/short	0b <a href="#">[4]</a>	unlocked memory
	209h	EPC	max. backscatter strength	1b <a href="#">[4]</a>	unlocked memory
	20Ah	EPC	digital output	0b <a href="#">[4]</a>	unlocked memory
	20Bh	EPC	read range reduction on/off	0b <a href="#">[4]</a>	unlocked memory
	20Ch	EPC	read protect User Memory	0b <a href="#">[4]</a>	locked memory
	20Dh	EPC	read protect EPC Bank	0b <a href="#">[4]</a>	unlocked memory
	20Eh	EPC	read protect TID	0b <a href="#">[4]</a>	unlocked memory
20Fh	EPC	PSF alarm flag	0b <a href="#">[4]</a>	unlocked memory	

Table 8. UCODE G2iM and UCODE G2iM+ overall memory map

Bank address	Memory address	Type	Content	Initial	Remark
Bank 10 TID	00h to 07h	TID	allocation class identifier	1110 0010b	locked memory
	08h to 13h	TID	tag mask designer identifier	0000 0000 0110b	locked memory
	14h	TIG	config word indicator	1b <sup>[2]</sup>	locked memory
	14h to 1Fh	TID	tag model number	TMNR <sup>[3]</sup>	locked memory
	20h to 2Fh	TID	XTID Header	00h	locked memory
	30h to 5Fh	TID	serial number	SNR	locked memory
	60h to CFh	TID	User TID memory	all '0'	unlocked memory
Bank 11 USER	000h to 27Fh	USER	User Memory	undefined	unlocked memory

- [1] UCODE G2iM: HEX E200 680A 0000 0000 0000 0000 (0000 0000)  
UCODE G2iM+: HEX E200 680B 0000 0000 0000 0000 (0000 0000)
- [2] Indicates the existence of a Configuration Word at the end of the EPC number
- [3] See [Figure 5](#)
- [4] See also [Table 13](#) for further details.

### 10.6.2 UCODE G2iM and UCODE G2iM+ TID memory details

Table 9. G2iM TID description

Type	First 32 bit of TID memory	Class ID	Mask designer ID	Model number		
				Config Word indicator	Sub version number	Version (Silicon) number
UCODE G2iM	E200680A	E2h	006h	1	0000b	0001010
UCODE G2iM+	E200680B	E2h	006h	1	0000b	0001011

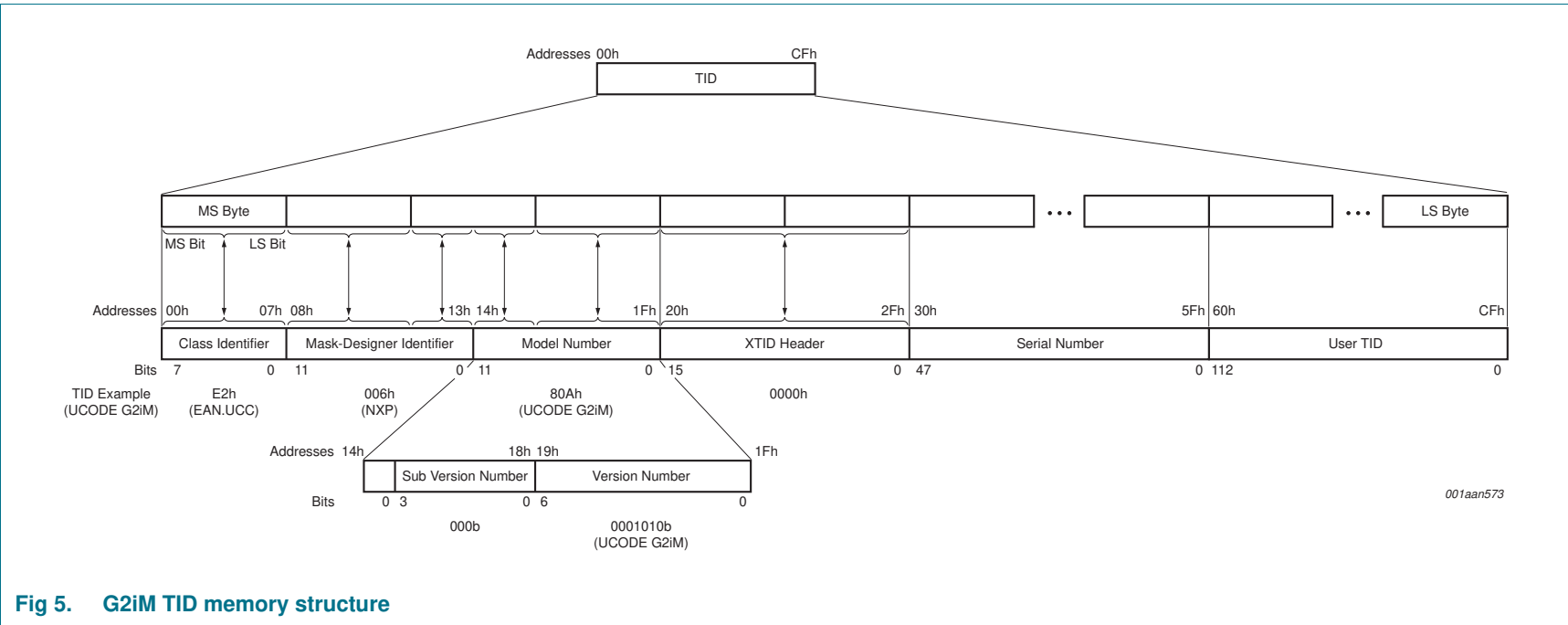

Fig 5. G2iM TID memory structure



## 10.7 Custom commands

The UCODE G2iM and UCODE G2iM+ supports a number of additional features and custom commands. Nevertheless, the chip is designed in a way standard EPCglobal READ/WRITE/ACCESS commands can be used to operate the features.

The memory map stated in the previous section describes the Config-Word used to control the additional features located at address 200h as well as the Mem-Config-Word located at 1F0h of the EPC memory. For this reason the standard READ/WRITE commands of an UHF EPCglobal compliant reader can be used to select the flags, activate/deactivate features or define memory segments.

The features can only be activated/deactivated (written) using standard EPC WRITE command as long the EPC is not locked. In case the EPC is locked either the bank needs to be unlocked to apply changes or the ChangeConfig custom command is used to change the settings.

The UCODE G2iM products supports the complete UCODE G2iL command set for backward compatibility reasons.

Bit 14h of the TID indicates the existence of a Configuration Word. This flag will enable selecting Config-Word enhanced transponders in mixed tag populations.

### 10.7.1 ChangeConfig

Although UCODE G2iM is tailored for supply chain management, item level tagging and product authentication the UCODE G2iM+ version enables active interaction with products. Among the password protected features are the capability of download firmware to electronics, activate/deactivate electronics which can also be used as theft deterrence, a dedicated privacy mode by reducing the read range, integrated PSF (Product Status Flag) or Tag Tamper Alarm. In addition to the UCODE G2iL/G2iL+ the activation condition (open/short) for the Read Range Reduction can be defined by the user.

The UCODE G2iM ChangeConfig custom command allows handling the special NXP Semiconductors features described in the following paragraph. Please also see the memory map in [Section 10.6 “UCODE G2iM and UCODE G2iM+ memory”](#) and [“Section 10.7.2 “UCODE G2iM and UCODE G2iM+ special features control mechanism”](#). If the EPC memory is not write locked the standard EPC READ/WRITE command can be used to change the settings.

#### UCODE G2iM and UCODE G2iM+ special features<sup>1</sup>

UCODE G2iM and UCODE G2iM+ common special features are:

- **Bank wise read protection** (separate for EPC, TID and User Memory)  
EPC bank (except of configuration words), the serial number part of the TID as well as the User TID and the User Memory (open segment) can be read protected independently. When protected reading of the particular memory will return '0'. The flags of the Config-Word can be selected using the standard SELECT command. Only read protected parts will then participate an inventory round.

1. The features can only be manipulated (enabled/disabled) with unlocked EPC bank, otherwise the ChangeConfig command can be used.

- **Integrated PSF (Product Status Flag)**

The PSF is a general purpose flag that can be used as an EAS (Electronic Article Surveillance) flag, quality checked flag or similar.

The UCODE G2iM offers two ways of detecting an activated PSF. In cases extremely fast detection is needed the EAS\_Alarm command can be used. The UCODE G2iM will reply a 64 bit alarm code like described in section EAS\_Alarm upon sending the command. As a second option the EPC SELECT command selecting the PSF flag of the Config-Word can be used. In the following inventory round only PSF enabled chips will reply their EPC number.

- **Backscatter strength reduction**

The UCODE G2iM features two levels of backscatter strengths. Per default maximum backscatter is enabled in order to enable maximum read rates. When clearing the flag the strength can be reduced if needed.

UCODE G2iM+ specific special features are:<sup>1</sup>

- **Real Read Range Reduction 4R (UCODE G2iM+ only)**

Some applications require the reduction of the read range to close proximity for privacy reasons. Setting the 4R flag will significantly reduce the chip sensitivity to +12 dBm. The +12 dBm have to be available at chip start up (slow increase of field strength is not applicable). For additional privacy, the read protection can be activated in the same configuration step. The related flag of the configuration word can be selected using the standard SELECT command so only chips with reduced read range will be part of an inventory.

**Remark:** The attenuation will result in only a few centimeter of read range at 36 dBm EIRP!

- **Tag Tamper Alarm (UCODE G2iM+ only)**

The UCODE G2iM+ Tamper Alarm will flag the status of the VDD to OUT pad connection which can be designed as an predetermined breaking point (see [Figure 6](#)).

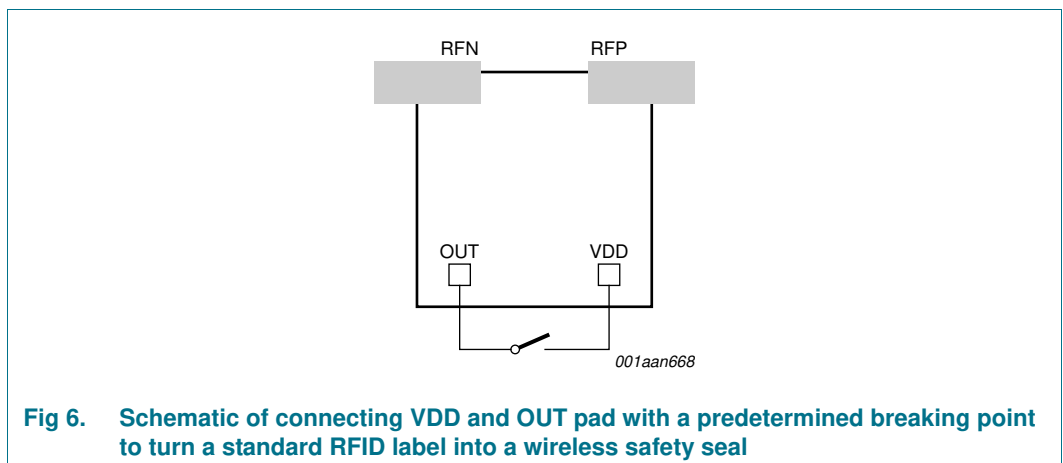

**Fig 6. Schematic of connecting VDD and OUT pad with a predetermined breaking point to turn a standard RFID label into a wireless safety seal**

The status of the pad connection (open/closed) can be read in the configuration register and/or selected using the EPC SELECT. This feature enables the design of a wireless RFID safety seal. When breaking the connection by peeling off the label or manipulating a lock an alarm can be triggered.

- Conditional Real Read Range Reduction (UCODE G2iM+ only)**

In addition to the 4R and the Tag Tamper Alarm feature the UCODE G2iM+ offers a feature which combines both in one functionality. This feature allow the automatic activation of the 4R depending on the status of the VDD to OUT pad connection. To offer high flexibility for the applications the 4R activation can be done on short (bit 8 = '1') or open (bit 8 = '0') of the VDD to OUT pad connection. For activation of this feature bit 7 and bit 11 of the Config-Word have to be set to '1'.
- Digital Switch (UCODE G2iM+ only)**

By connecting a supply voltage between RFN and VDD the OUT pin of the UCODE G2iM+ can be used as digital switch. Depending on the 'Digital Output' bit of the Config-Word register the state of the OUT pin can be switched to VDD or GND. The state of the OUT pin is persistent in the memory even after KILL or switching off the supply. In absence of external Vsupply, one cannot detect the difference in Ohmic resistance between OUT and VDD, regardless of whether 'Digital Output' bit is 0 or 1. The state of the OUT pin can also be changed temporary by toggling the 'Invert Digital Output' bit.

This feature will allow activating/deactivating externally connected peripherals or can be used as theft deterrence of electronics.
- Data transfer Mode (UCODE G2iM+ only)**

In applications where not switching the output like described in "Digital Switch" but external device communication is needed the UCODE G2iM+ Data Transfer Mode can be used by setting the according bit of the Config-Word register. When activated the air interface communication will be directly transferred to the OUT pad of the chip.

Two modes of data transfer are available and can be switched using the Transparent Mode DATA/RAW bit.

The default Transparent Mode DATA will remove the Frame Sync of the communication and toggle the output with every raising edge in the RF field. This will allow implementing a Manchester type of data transmission.

The Transparent Mode RAW will switch the demodulated air interface communication to the OUT pad.
- External Supply Indicator - Digital Input (UCODE G2iM+ only)**

The VDD pad of the UCODE G2iM+ can be used as a digital input pin. The state of the pad is directly associated with the External Supply Indicator bit of the configuration register. A simple return signaling (chip to reader) can be implemented by polling this Configuration Word register flag. RF reset is necessary for proper polling.
- External Supply Mode (G2iM+ only)**

The UCODE G2iM+ can be supplied externally by connecting 1.85 V (Iout = 0  $\mu$ A) supply. When externally supplied less energy from the RF field is needed to operate the chip. This will not just enable further improved sensitivity and read ranges (up to -27 dBm) but also enable a write range that is equal to the read range.

The figure schematically shows the supply connected to the UCODE G2iM+.

**Remark:** When permanently externally supplied there will not be a power-on-reset. This will result in the following limitations:

- When externally supplied session flag S0 will keep it's state during RF-OFF phase.
- When externally supplied session flag S2, S3, SL will have infinite persistence time and will behave similar to S0.
- Session flag S1 will behave regular like in pure passive operation.

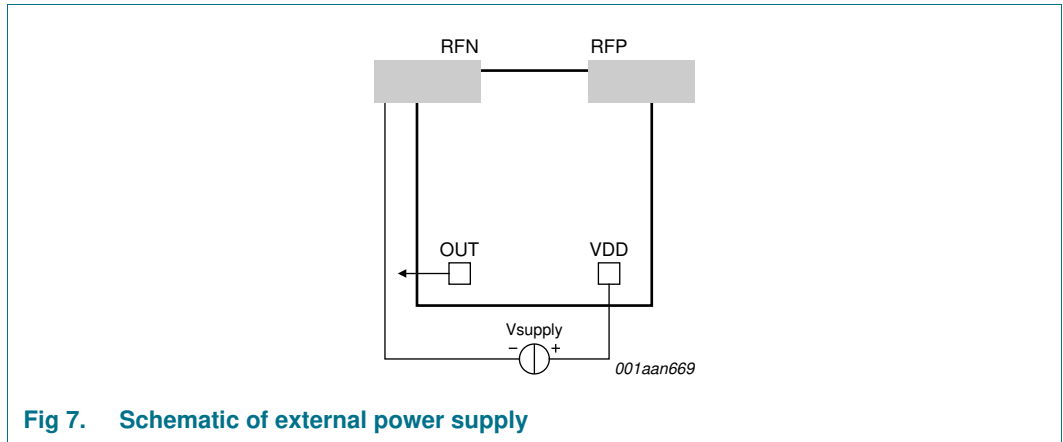

Fig 7. Schematic of external power supply

Table 10. ChangeConfig custom command

	Command	RFU	Data	RN	CRC-16
No. of bits	16	8	16	16	16
Description	11100000 00000111	00000000	Toggle bits XOR RN 16	handle	-

The bits to be toggled in the configuration register need to be set to '1'.

E.g. sending 0000 0000 0001 0001 XOR RN16 will activate the 4R and PSF. Sending the very same command a second time will disable the features again.

The reply of the ChangeConfig will return the current register setting.

Table 11. ChangeConfig custom command reply

	Header	Status bits	RN	CRC-16
No. of bits	1	16	16	16
Description	0	Config-Word	Handle	-

Table 12. ChangeConfig command-response table

Starting state	Condition	Response	Next state
ready	all	-	ready
arbitrate, reply, acknowledged	all	-	arbitrate
open	valid handle Status word needs to change	Backscatter unchanged Config-Word immediately	open
	valid handle Status word does not need to change	Backscatter Config-Word immediately	open
secured	valid handle Status word needs to change	Backscatter modified Config-Word, when done	secured
	valid handle Status word does not need to change	Backscatter Config-Word immediately	secured
killed	all	-	killed

The features can only be activated/deactivated using standard EPC WRITE if the EPC bank is unlocked. The permanent and temporary bits of the Configuration Word can be toggled without the need for an Access Password in case the Access Password is set to zero. In case the EPC bank is locked the lock needs to be removed before applying changes or the ChangeConfig command has to be used.

### 10.7.2 UCODE G2iM and UCODE G2iM+ special features control mechanism

Special features of the UCODE G2iM are managed using a configuration word (Config-Word) located at address 200h in the EPC memory bank.

The entire Config-Word is selectable (using the standard EPC SELECT command), as well as single bits, and can be read using standard EPC READ command and modified using the standard EPC WRITE or ChangeConfig custom command in case the EPC memory is locked for writing.

ChangeConfig can be executed from the OPEN and SECURED state. The chip will take all "Toggle Bits" for '0' if the chip is in the OPEN state or the ACCESS password is zero; therefore it will not alter any status bits, but report the current status only. The command will be ignored with an invalid CRC-16 or an invalid handle. The chip will then remain in the current state. The CRC-16 is calculated from the first command-code bit to the last handle bit.

A ChangeConfig command without frame-sync and proceeding Req\_RN will be ignored. The command will also be ignored if any of the RFU bits are toggled.

In order to change the configuration, to activate/deactivate a feature a '1' has to be written to the corresponding register flag to toggle the status. E.g. sending 0x0002 to the register will activate the read protection of the TID. Sending the same command a second time will again clear the read protection of the TID. Invalid toggling on indicator or RFU bits are ignored.

Executing the command with zero as payload or in the OPEN state will return the current register settings. The chip will reply to a successful ChangeStatus with an extended preamble regardless of the TRext value of the Query command.

After sending a ChangeConfig an interrogator shall transmit CW for less than TReply or 20ms, where TReply is the time between the interrogator's ChangeConfig command and the chip's backscattered reply. An interrogator may observe three possible responses after sending a ChangeConfig, depending on the success or failure of the operation

- ChangeConfig succeeded: The chip will backscatter the reply shown above comprising a header (a 0-bit), the current Config-Word setting, the handle, and a CRC-16 calculated over the 0-bit, the Config-Word and the handle. If the interrogator observes this reply within 20 ms then the ChangeConfig completed successfully.
- The chip encounters an error: The chip will backscatter an error code during the CW period rather than the reply shown below (see EPCglobal Spec for error-code definitions and for the reply format).
- ChangeConfig does not succeed: If the interrogator does not observe a reply within 20 ms then the ChangeConfig did not complete successfully. The interrogator may issue a Req\_RN command (containing the handle) to verify that the chip is still in the interrogator's field, and may reissue the ChangeConfig command.

The UCODE G2iM configuration word (Config-Word) is located at address 200h of the EPC memory and is structured as following:

Table 13. Address 200h to 207h

Indicator bits				Temporary bits			Permanent bits
Tamper indicator	External supply indicator	RFU	RFU	Invert Output	Transparent mode on/off	Data mode data/raw	Conditional Read Range Reduction on/off
0	1	2	3	4	5	6	7

Table 14. Address 208h to 20Fh

Permanent bits							
Conditional Read Range Reduction open/short	max. backscatter strength	Digital output	Read Range Reduction	Protect UM	Protect EPC	Protect TID	PSF Alarm bit
8	9	10	11	12	13	14	15

The configuration word contains three different type of bits:

- **Indicator bits** cannot be changed by command:
  - Tag Tamper Alarm Indicator
  - External Supply Indicator (digital input)
- **Temporary bits** are reset at power up:
  - Invert Output
  - Transparent Mode on/off
  - Data Mode data/raw
- **Permanent bits:** permanently stored bits in the memory
  - Conditional Read Range Reduction on/off
  - Conditional Read Range Reduction short/open
  - Max. Backscatter Strength
  - Digital Output
  - Read Range Reduction
  - Read Protect User Memory
  - Read Protect EPC
  - Read Protect TID
  - PSF Alarm

**10.7.3 UCODE G2iM+ memory configuration control mechanism**

The segmented user memory available in the UCODE G2iM+ enables a flexible configuration of the device with respect to EPC size and access rights to the User Memory.

The standard configuration offers 256 bit EPC memory and 512 bit open User Memory for UCODE G2iM and 128 bit EPC memory and 640 bit open User Memory for UCODE G2iM+. For applications where more EPC memory is required the UCODE G2iM+ offers the flexibility to extend the 128 bit EPC up to 448 bit (in steps of 64 bit) by reducing the User Memory size accordingly. See [Table 15](#) and [Table 17](#).

**Table 15. EPC / User Memory Standard Configuration (UCODE G2iM)**

EPC Memory	User Memory
	Open
256 bit	512 bit

**Table 16. EPC / User Memory Standard Configuration (UCODE G2iM+)**

EPC Memory	User Memory
	Open
128 bit	640 bit

**Table 17. EPC / User Memory Max. EPC Configuration (UCODE G2iM+)**

EPC Memory	User Memory
	Open
448 bit	320 bit

Beside the possibility to extend the EPC memory the UCDOE G2iM+ offers the possibility to segment the User Memory in up to three areas with different access rights.

- Open: no read/write protection
- Protected: read/write protected by the Access Password
- Private: read/write protected by the User Password (see [Section 10.7.4](#))

The memory configuration can be defined one time, by programming the memory configuration word, at the initialization of the UCODE G2iM+. The UCODE G2iM+ Memory Configuration Word (Mem-Config-Word) is located at address 1F0h of the EPC memory and is structured as following:

**Table 18. Memory Configuration Word, Address 1F0h to 1FFh**

RFU				Number of EPC blocks				Number of Protected memory blocks				Number of Private memory blocks			
0	1	2	3	4	5	6	7	8	9	10	11	12	13	14	15

- RFU-Bits:**  
 The four RFU bits are fixed to 0000b. These four bits are ignored for access commands (e.g. WRITE).
- Number of EPC blocks:**  
 The 4 bit of this region specify the number of blocks (max. 5) which should be added on top of the standard EPC Memory of 128bit.
- Number of Protected memory blocks:**  
 The 4 bit of this region specify the number of blocks which should be used for the Protected memory region.
- Number of Private memory blocks:**  
 The 4 bit of this region specify the number of blocks which should be used for the Private memory region.

The total amount of User Memory is defined by the number of blocks for EPC-, Open-, Protected- and Private- memory area. Based on the total User Memory size (640 bit) and the defined block size of 64 bit, the overall number of blocks results in ten blocks. As described in the examples (Table 19 to Table 21) below the blocks used for the EPC-, Open-, Protected- or Private segment can be exchanged according to the application requirements as long as the overall block number is below ten.

The number of blocks allocated to the Open Memory Area are defined by the number of blocks specified in the Mem-Config-Word, therefore the size of the Open Memory area is derived by subtracting the number of defined blocks (Mem-Config-Word) from the total available number of blocks of the User Memory (10 blocks). Undefined blocks are always added to the Open Memory area.

In case an invalid total amount of blocks (exceeds ten) is written to the Mem-Config-Word, the configuration fails and the error code (Locked Memory) will be returned.

The entire Mem-Config-Word is selectable (using the standard EPC SELECT command), as well as single bits, and can be read using standard EPC READ command and modified using the standard EPC WRITE command.

**NOTE:**

THE MEM-CONFIG-WORD IS ONE TIME PROGRAMMABLE.

Programming has be performed in the secured state.

In case no programming of the memory configuration word is done at the initialization of the UCODE G2iM+ it will be automatically locked upon a lock of any part of the memory.



The following tables will provide a few examples for different memory configurations.

- Standard EPC size, 4 blocks Protected and 3 blocks Private memory which results in 3 blocks Open memory. (Mem-Config-Word value: 0043h)  
See [Table 19](#)

**Table 19. User Memory Configuration with 3 segments**

EPC Memory	User Memory		
	Open	Protected	Private
128 bit	192 bit	256 bit	192 bit

- Standard EPC size, 3 blocks Protected memory which results in 7 blocks Open memory. (Mem-Config-Word value: 0030h).  
See [Table 20](#)

**Table 20. User Memory Configuration with 2 segments (no Private segment)**

EPC Memory	User Memory	
	Open	Protected
128 bit	448 bit	192 bit

- 192 bit EPC (1 block EPC added), 6 blocks Private memory which results in 4 blocks Open memory. (Mem-Config-Word value: 0106h)  
See [Table 21](#)

**Table 21. User Memory Configuration with 2 areas (no Access password protected area)**

EPC Memory	User Memory	
	Open	Private
192 bit	192 bit	384 bit

### 10.7.4 Private Memory Segment

The Private memory is a part of the User Memory which can be accessed out of the secured state only. Private regions will appear as non existent to not authorized users.

The address of the location of the User Password is not fixed and has therefore to be calculated based on the applied memory configuration.

The 32 bit User Password is located at the end of the User Memory. Since the UCODE G2iM+ memory is configurable and can be segmented the address location of the User Password depends on the Memory configuration done at the initialization.

User Password address calculation:

$$\text{HEX}[(\text{Total number of memory blocks} - \text{blocks appointed to EPC}) * \text{Blocksize}]$$

Example:

EPC length: 192

This means that 1 block from the User Memory is required (128 bit + 64 bit)

$$\text{HEX}[(10-1)*64]=\text{HEX}[9*64]=\text{HEX}[384]=240\text{h}$$

Therefore the User Password for this configuration is located at address 240h to 25Fh

10.7.5 ReadProtect<sup>2</sup>

The UCODE G2iM ReadProtect custom command enables reliable read protection of the entire UCODE G2iM memory. Executing ReadProtect from the Secured state will set the ProtectEPC and ProtectTID bits of the Configuration Word to '1'. With the ReadProtect-Bit set the UCODE G2iM will continue to work unaffected but veil its protected content.

The read protection can be removed by executing Reset ReadProtect. The ReadProtect-Bits will than be cleared.

Devices whose access password is zero will ignore the command. A frame-sync must be pre-pended the command.

After sending the ReadProtect command an interrogator shall transmit CW for the lesser of  $T_{Reply}$  or 20 ms, where  $T_{Reply}$  is the time between the interrogator's ReadProtect command and the backscattered reply. An interrogator may observe three possible responses after sending a ReadProtect, depending on the success or failure of the operation:

- ReadProtect succeeds: After completing the ReadProtect the UCODE G2iM shall backscatter the reply shown in [Table 23](#) comprising a header (a 0-bit), the tag's handle, and a CRC-16 calculated over the 0-bit and handle. Immediately after this reply the UCODE G2iM will render itself to this ReadProtect mode. If the interrogator observes this reply within 20 ms then the ReadProtect completed successfully.
- The UCODE G2iM encounters an error: The UCODE G2iM will backscatter an error code during the CW period rather than the reply shown in the EPCglobal Spec (see Annex I for error-code definitions and for the reply format).
- ReadProtect does not succeed: If the interrogator does not observe a reply within 20 ms then the ReadProtect did not complete successfully. The interrogator may issue a Req\_RN command (containing the handle) to verify that the UCODE G2iM is still in the interrogation zone, and may re-initiate the ReadProtect command.

The UCODE G2iM reply to the ReadProtect command will use the extended preamble shown in EPCglobal Spec (Figure 6.11 or Figure 6.15), as appropriate (i.e. a Tag shall reply as if  $T_{Rext}=1$ ) regardless of the  $T_{Rext}$  value in the Query that initiated the round.

Table 22. ReadProtect command

	Command	RN	CRC-16
# of bits	16	16	16
description	11100000 00000001	handle	-

Table 23. UCODE G2iM reply to a successful ReadProtect procedure

	Header	RN	CRC-16
# of bits	1	16	16
description	0	handle	-

2. Note: The ChangeConfig command can be used instead of "ReadProtect", "ResetReadProtect", "ChangeEAS".