



Chipsmall Limited consists of a professional team with an average of over 10 year of expertise in the distribution of electronic components. Based in Hongkong, we have already established firm and mutual-benefit business relationships with customers from,Europe,America and south Asia,supplying obsolete and hard-to-find components to meet their specific needs.

With the principle of "Quality Parts,Customers Priority,Honest Operation,and Considerate Service",our business mainly focus on the distribution of electronic components. Line cards we deal with include Microchip,ALPS,ROHM,Xilinx,Pulse,ON,Everlight and Freescale. Main products comprise IC,Modules,Potentiometer,IC Socket,Relay,Connector.Our parts cover such applications as commercial,industrial, and automotives areas.

We are looking forward to setting up business relationship with you and hope to provide you with the best service and solution. Let us make a better world for our industry!



Contact us

Tel: +86-755-8981 8866 Fax: +86-755-8427 6832

Email & Skype: info@chipsmall.com Web: www.chipsmall.com

Address: A1208, Overseas Decoration Building, #122 Zhenhua RD., Futian, Shenzhen, China





SL-630 SERIES

SPECIFICATIONS

- High/low liquid level monitor
- “Peel and stick” to the outside of a wide range of plastic containers
- Never comes in contact with liquid – no risk of contamination or volume displacement
- Proven ultrasonic technology
- Repeatability: ± 0.1 ” (2.54 mm)

The Non-Invasive Sonic Eye™ SL-630 is a cost effective ultrasonic sensor for plastic containers. The sensor is designed to adhere to the outside of plastic containers with diameters from 2” (50.8mm) to 10” (254mm) with a wall thickness up to 0.25” (6.35mm) as a high/low level liquid level monitor. The sensor sticks to the outside of the container, never coming in contact with the liquid, so there is no contamination or volume displacement.

FEATURES

- No calibration required
- Non-invasive miniature sensor designed to stick to outside of container
- Integral electronics with disposable mounting
- Effective on plastic bottles with diameters ranging from 2” (50.8 mm) to 10” (254 mm)
- Independent of color, transparency, shape and size of bottom of container
- No displacement of liquid volume
- Eliminates fluid contamination problem

APPLICATIONS

- Chemical Analyzer
- Immuno Chemistry
- Chromatography
- Kidney Dialysis
- Clinical Chemistry
- Medical Laser System
- Hemodialysis
- Semiconductor
- Waste Management

PERFORMANCE SPECIFICATIONS

Parameter	Typical Value
Repeatability	± 0.1" (2.54 mm)
Response Time	200 milliseconds
Input Power	5 to 24 VDC
Leakage Current	Less than 50 µA
Output	TTL (high) – dry condition
Mounting	Reusable sensor/disposable mounting tape

Parameter	Typical Value
Protection	Transient, reverse polarity
Effective Plastic Bottle Diameter	2" (50.8 mm) to 10" (254 mm)
Wall Thickness	Up to 0.25" (6.35 mm)
Sensor Material	ULTEM® (plastic)
Temperature	-20 to 158 °F (30 to 70 °C)
Cable Length	12" (305 mm) (for longer lengths consult factory)

MECHANICAL DIMENSIONS IN INCHES

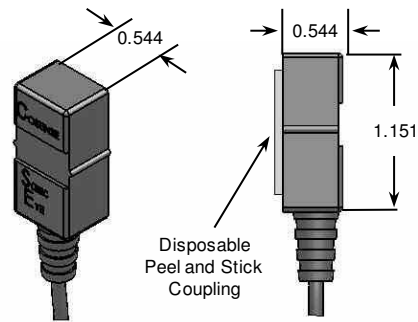

Figure 1: SL-630 series element with peel and stick disposable mounting tape.

NOTES: Clean area on container before installing. Remove backing from tape and adhere to container. Press sensor to container firmly

WIRING DIAGRAM

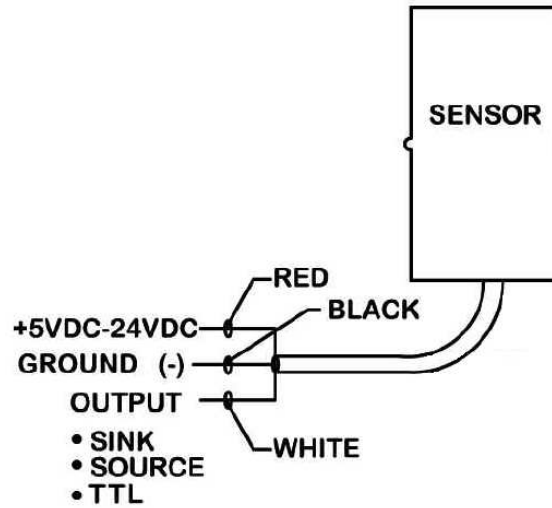

Figure 3: Wiring diagram for SL-630 series elements.

ORDERING INFORMATION

Input	Output	Part Number
5 – 24 VDC	TTL	SL-630-C01

NORTH AMERICA

Measurement Specialties, Inc.,
 a TE Connectivity Company
 1000 Lucas Way
 Hampton, VA 23666
 Tel: 1-800-745-8008
 Fax: 1-757-766-4297
 Sales: piezo@meas-spec.com

EUROPE

MEAS Deutschland GmbH
 a TE Connectivity Company
 Hauert 13
 44227 Dortmund
 Germany
 Sales & Customer Service: +49 (0)231 9740 21
 Technical Support: +44 (0)138 38700 01
 Email: piezoeurope@meas-spec.com

ASIA

Measurement Specialties (China), Ltd.,
 a TE Connectivity Company
 No. 26 Langshan Road,
 High-Tech Park (North)
 Nanshan District, Shenzhen 518057
 Tel: +86 755 3330 5068
 Email: sales.china@meas-spec.com

TE.com/sensorsolutions

Measurement Specialties, Inc., a TE Connectivity company.

Measurement Specialties, TE Connectivity, TE Connectivity (logo) and EVERY CONNECTION COUNTS are trademarks. All other logos, products and/or company names referred to herein might be trademarks of their respective owners.

The information given herein, including drawings, illustrations and schematics which are intended for illustration purposes only, is believed to be reliable. However, TE Connectivity makes no warranties as to its accuracy or completeness and disclaims any liability in connection with its use. TE Connectivity's obligations shall only be as set forth in TE Connectivity's Standard Terms and Conditions of Sale for this product and in no case will TE Connectivity be liable for any incidental, indirect or consequential damages arising out of the sale, resale, use or misuse of the product. Users of TE Connectivity products should make their own evaluation to determine the suitability of each such product for the specific application.

© 2015 TE Connectivity Ltd. family of companies All Rights Reserved.