



Chipsmall Limited consists of a professional team with an average of over 10 year of expertise in the distribution of electronic components. Based in Hongkong, we have already established firm and mutual-benefit business relationships with customers from,Europe,America and south Asia,supplying obsolete and hard-to-find components to meet their specific needs.

With the principle of “Quality Parts,Customers Priority,Honest Operation,and Considerate Service”,our business mainly focus on the distribution of electronic components. Line cards we deal with include Microchip,ALPS,ROHM,Xilinx,Pulse,ON,Everlight and Freescale. Main products comprise IC,Modules,Potentiometer,IC Socket,Relay,Connector.Our parts cover such applications as commercial,industrial, and automotives areas.

We are looking forward to setting up business relationship with you and hope to provide you with the best service and solution. Let us make a better world for our industry!



Contact us

Tel: +86-755-8981 8866 Fax: +86-755-8427 6832

Email & Skype: info@chipsmall.com Web: www.chipsmall.com

Address: A1208, Overseas Decoration Building, #122 Zhenhua RD., Futian, Shenzhen, China



RFID with Senses

www.ams.com/SL900A

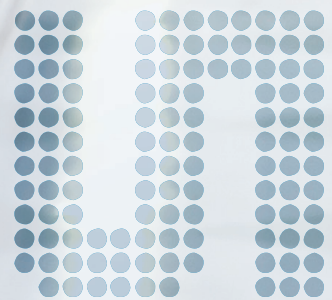

SL900A – EPC Gen2 Sensor Tag IC

- Single-chip RFID data logger
- On-chip temperature sensor
- Analog inputs for external sensors
- Works with or without battery (semi-passive or fully passive)
- 9k-bit EEPROM for data storage

We provide innovative analog solutions to the most challenging applications in sensor and sensor interfaces, power management, and wireless.

General Description

Sensor tags are RFID tags, which incorporate sensory functionality in addition to merely providing a unique ID. This allows validating the origin of any object as well as verifying the environmental conditions to which the object has been exposed. Adding sensor functions to the RFID technology opens new horizons for complex applications such as tracking and monitoring of objects and environments in any location.

The SL900A is such sensor tag adding a new dimension to the RFID technology. The chip is based on EPC Gen2 and incorporates a temperature sensor and an interface to various external sensors. The integrated real-time clock (RTC) time stamps the events. The SL900A has an integrated shelf life algorithm that can dynamically calculate the remaining shelf life of a product based on the Arrhenius equation.

It has an automatic alarm function for the shelf life expiration. The sensor tag works in fully passive as well as in semi-passive mode (so-called battery-assisted passive or BAP). A battery is used to support autonomous data logging with the on-chip RTC. In passive mode, the reader provides the time stamp, and the energy to the sensors is extracted from the reader's field (radio waves).

Collected and logged data are protected with passwords to preclude manipulation and unauthorized usage of the data. A perpetual protection is available through a permanent lock command, which inhibits changing of stored data independent of passwords.

Applications

- Perpetual tracking and recording of medication
- Perpetual tracking and monitoring of transportation
- Shelf-life monitoring
- Tracking condition and history of constructions (buildings, bridges, roads, etc.)
- Contactless metering
- Tire pressure monitoring systems (TPMS)
- Environmental monitoring

SL900A Block Diagram

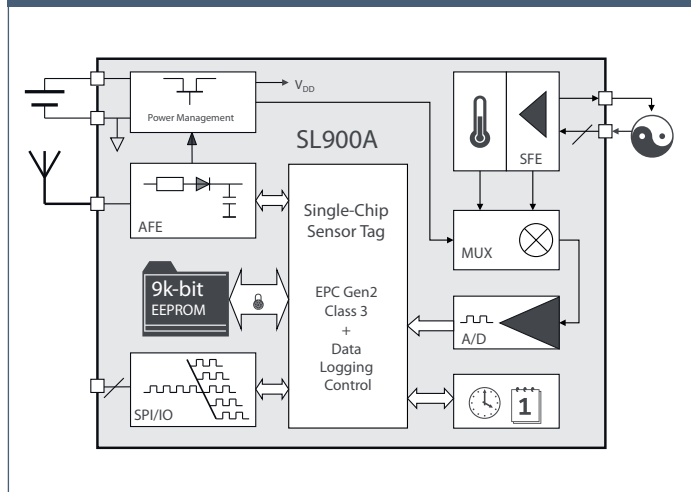

Features

- Logging storage capacity: max. 841 events with time stamp
- Compatible with EPC Gen2 and cool-Log™
- Analog inputs for external sensors (resistive, capacitive, opto or resistive bridge)
- Supports fast direct communication via SPI port
- Alarm function for shelf-life monitoring
- Event-driven alerts
- 9k-bit EEPROM
- Supply voltage range 1.2 to 3.6V
- Typical current consumption (@1.5V):
 - Standby (RTC Running): 1.6 µA
 - Operating (logging, 25ms): 200 µA
- Temperature range: -40°C to 125°C
- Works with 1.5V (single-cell) or 3V battery
- Energy harvesting from reader field to support external circuitry

www.ams.com
 products@ams.com
 © 02/2013 by ams
 Subject to change without notice

Headquarters
ams AG
 Tobelbader Strasse 30, 8141 Unterpremstaetten, Austria
 Phone +43 3136 500-0 • Fax +43 3136 525-01

Sales Offices Worldwide
 sales-europe@ams.com
 sales-asia@ams.com
 sales-america@ams.com