



Chipsmall Limited consists of a professional team with an average of over 10 year of expertise in the distribution of electronic components. Based in Hongkong, we have already established firm and mutual-benefit business relationships with customers from,Europe,America and south Asia,supplying obsolete and hard-to-find components to meet their specific needs.

With the principle of "Quality Parts,Customers Priority,Honest Operation,and Considerate Service",our business mainly focus on the distribution of electronic components. Line cards we deal with include Microchip,ALPS,ROHM,Xilinx,Pulse,ON,Everlight and Freescale. Main products comprise IC,Modules,Potentiometer,IC Socket,Relay,Connector.Our parts cover such applications as commercial,industrial, and automotives areas.

We are looking forward to setting up business relationship with you and hope to provide you with the best service and solution. Let us make a better world for our industry!



Contact us

Tel: +86-755-8981 8866 Fax: +86-755-8427 6832

Email & Skype: info@chipsmall.com Web: www.chipsmall.com

Address: A1208, Overseas Decoration Building, #122 Zhenhua RD., Futian, Shenzhen, China







SLA Series

Miniature Slide Switches

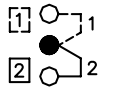
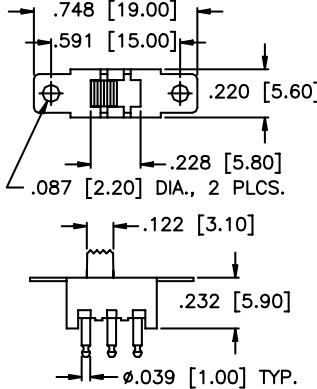
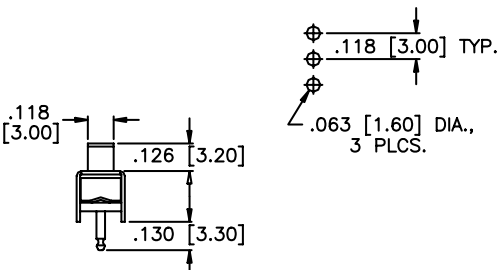
SPECIFICATIONS	FEATURES
<p>Contact ratings: 500 mA at 125 VAC</p> <p>Initial contact resistance: 20 milliohms max.</p> <p>Insulation resistance: 100 megohms min. at 500 VDC</p> <p>Dielectric strength: 500 volts RMS for 1 minute</p> <p>Electrical life: 10,000 cycles min.</p> <p>Operating temperature range: -20°C to +85°C</p> <p>Actuation force: 350g ± 200g</p> <p>Solder heat resistance: 260°C max. for 3 seconds</p> <p>Solvent washing permissible</p>	<ul style="list-style-type: none"> ● Miniature compact size. ● Wash-through open frame construction. ● Panel and p.c. mounting models.
	MATERIALS
	<p>Contacts & terminals: Silver plated brass</p> <p>Frame: Zinc plated steel</p> <p>Actuator: PBT Thermoplastic</p> <p>Base: Phenolic laminated sheet</p>

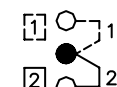
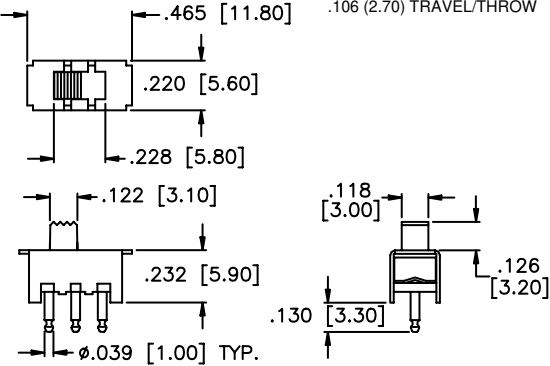
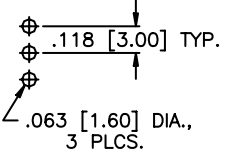
SPECIFICATIONS SUBJECT TO CHANGE WITHOUT NOTICE

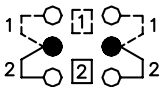
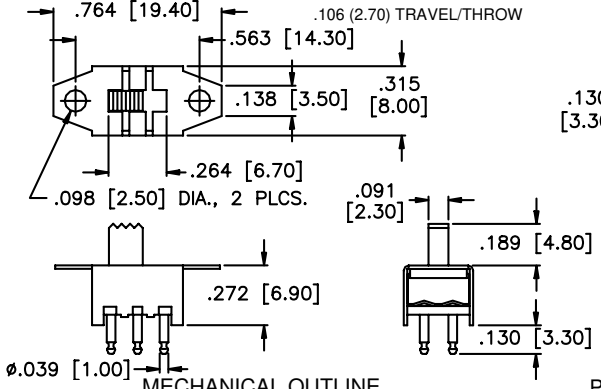
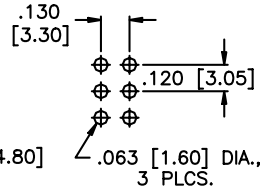
MODEL NO.			
SLA1200			
	1P2T  ● = COMMON	 SCHEMATIC MECHANICAL OUTLINE	 P.C. BOARD LAYOUT
MODEL NO.			
SLA1201			
	1P2T  ● = COMMON	 SCHEMATIC MECHANICAL OUTLINE	 P.C. BOARD LAYOUT
MODEL NO.			
SLA2200			
	2P2T  ● = COMMON	 SCHEMATIC MECHANICAL OUTLINE	 P.C. BOARD LAYOUT

SPECIFICATIONS SUBJECT TO CHANGE WITHOUT NOTICE

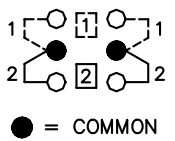
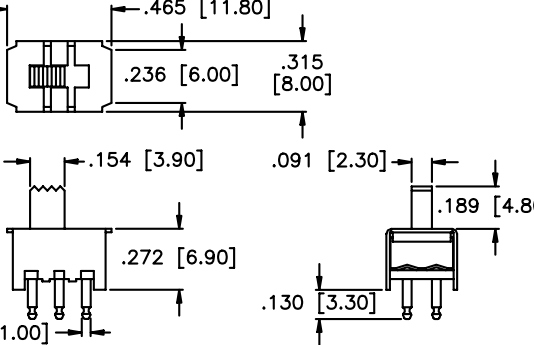
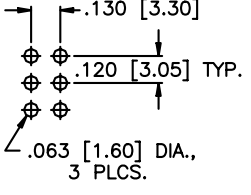
MODEL NO.	2P2T		
SLA2201			
	 <p>SCHMATIC</p>	 <p>MECHANICAL OUTLINE</p>	 <p>P.C. BOARD LAYOUT</p>

