



Chipsmall Limited consists of a professional team with an average of over 10 year of expertise in the distribution of electronic components. Based in Hongkong, we have already established firm and mutual-benefit business relationships with customers from,Europe,America and south Asia,supplying obsolete and hard-to-find components to meet their specific needs.

With the principle of "Quality Parts,Customers Priority,Honest Operation,and Considerate Service",our business mainly focus on the distribution of electronic components. Line cards we deal with include Microchip,ALPS,ROHM,Xilinx,Pulse,ON,Everlight and Freescale. Main products comprise IC,Modules,Potentiometer,IC Socket,Relay,Connector.Our parts cover such applications as commercial,industrial, and automotives areas.

We are looking forward to setting up business relationship with you and hope to provide you with the best service and solution. Let us make a better world for our industry!



## Contact us

Tel: +86-755-8981 8866 Fax: +86-755-8427 6832

Email & Skype: info@chipsmall.com Web: www.chipsmall.com

Address: A1208, Overseas Decoration Building, #122 Zhenhua RD., Futian, Shenzhen, China



### Absolute maximum ratings

( $T_a=25^\circ\text{C}$ )

Symbol	Ratings	Unit
$V_{DSS}$	60	V
$V_{GSS}$	$\pm 20$	V
$I_D$	7	A
$I_D(\text{pulse})$	15 ( $PW \leq 100\mu\text{s}$ , $D_u \leq 1\%$ )	A
$E_{AS}^*$	60	mJ
$I_{AS}$	7	A
$P_T$	5 ( $T_a=25^\circ\text{C}$ , with all circuits operating, without heatsink)	W
	50 ( $T_c=25^\circ\text{C}$ , with all circuits operating, with infinite heatsink)	
$\theta_{j-a}$	25 (Junction-Air, $T_a=25^\circ\text{C}$ , with all circuits operating)	$^\circ\text{C/W}$
$\theta_{j-c}$	2.5 (Junction-Case, $T_c=25^\circ\text{C}$ , with all circuits operating)	$^\circ\text{C/W}$
$V_{ISO}$	1000 (Between fin and lead pin, AC)	Vrms
$T_{ch}$	150	$^\circ\text{C}$
$T_{stg}$	-40 to +150	$^\circ\text{C}$

\* :  $V_{DD}=20\text{V}$ ,  $L=20\text{mH}$ ,  $I_D=2\text{A}$ , unclamped,  $R_G=50\Omega$ , see Fig. E on page 15.

### Equivalent circuit diagram

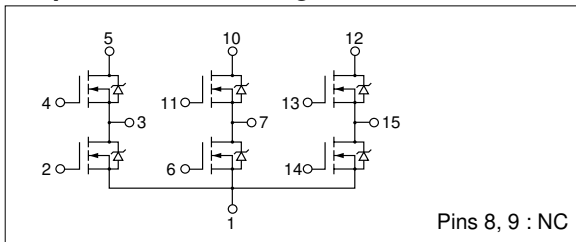

Pins 8, 9 : NC

### Electrical characteristics

( $T_a=25^\circ\text{C}$ )

Symbol	Specification			Unit	Conditions
	min	typ	max		
$V_{(BR)DSS}$	60			V	$I_D=100\mu\text{A}$ , $V_{GS}=0\text{V}$
$I_{GSS}$			$\pm 100$	nA	$V_{DS}=\pm 20\text{V}$
$I_{DSS}$			100	$\mu\text{A}$	$V_{DS}=60\text{V}$ , $V_{GS}=0\text{V}$
$V_{TH}$	1.0		2.0	V	$V_{DS}=10\text{V}$ , $I_D=250\mu\text{A}$
$R_{e(yfs)}$	6			S	$V_{DS}=10\text{V}$ , $I_D=3.5\text{A}$
$R_{DS(ON)}$			0.1	$\Omega$	$V_{GS}=10\text{V}$ , $I_D=3.5\text{A}$
$C_{iss}$		660		pF	$V_{DS}=10\text{V}$ , $f=1.0\text{MHz}$ , $V_{GS}=0\text{V}$
$C_{oss}$		310		pF	
$C_{rss}$		75		pF	
$t_{d(on)}$		30		ns	$I_D=3.5\text{A}$ , $V_{DD} \approx 20\text{V}$ , $R_L=5.7\Omega$ , $V_{GS}=5\text{V}$ , see Fig. 3 on page 16.
$t_r$		90		ns	
$t_{d(off)}$		140		ns	
$t_f$		65		ns	
$V_{SD}$		1.1		V	
$t_{rr}$		80		ns	$I_{SD}=3.5\text{A}$ , $di/dt=100\text{A}/\mu\text{s}$

### Characteristic curves

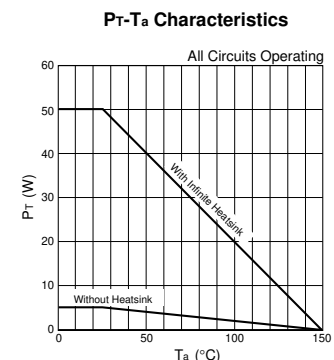
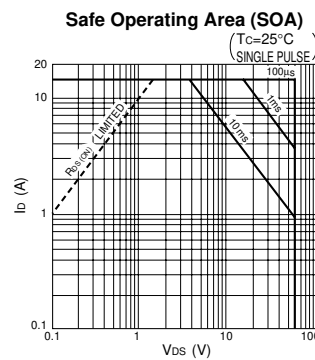
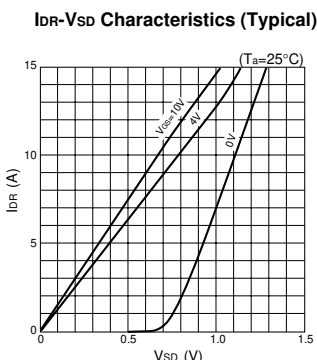
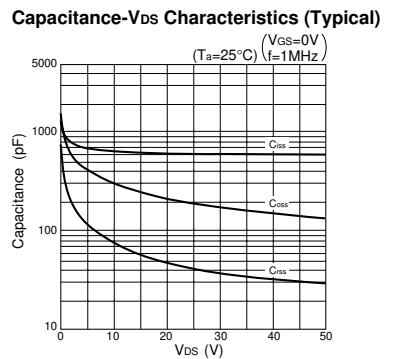
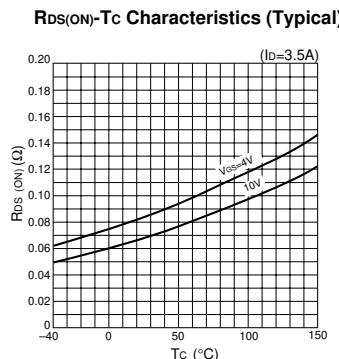
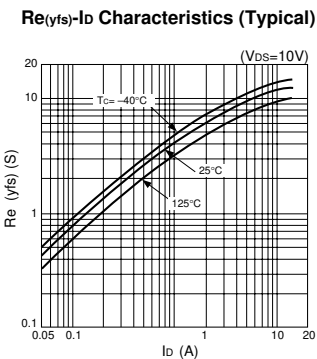
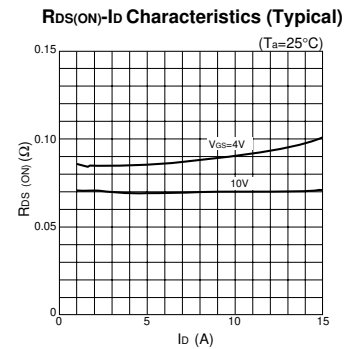
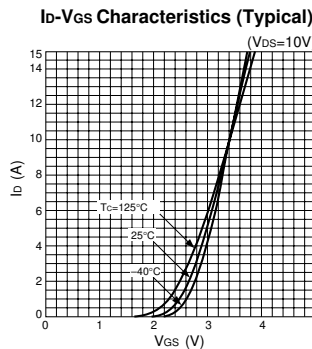
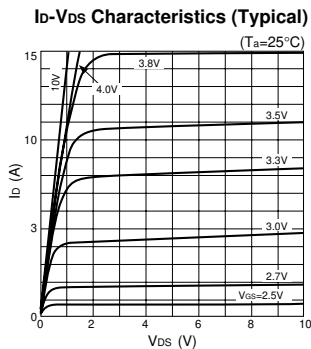

• SIP 8 (STA8Pin)

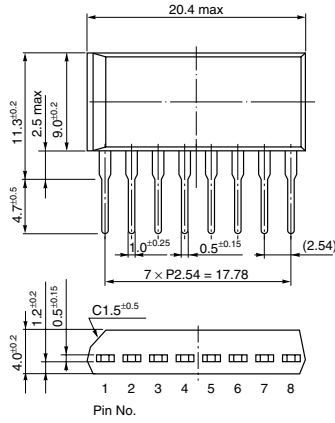

• SIP 10 (STA10Pin)

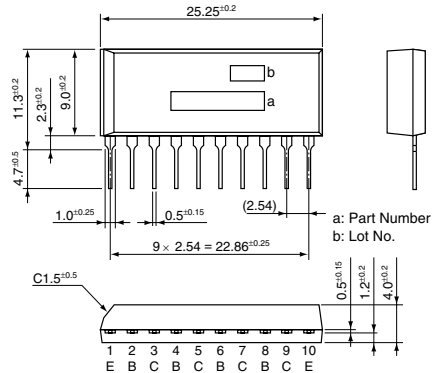

• PS 16 (Surface-Mount)

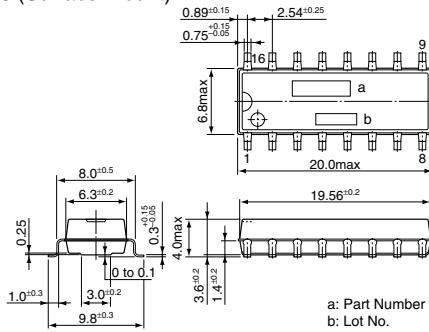

• SIP 12 (SMA12Pin)

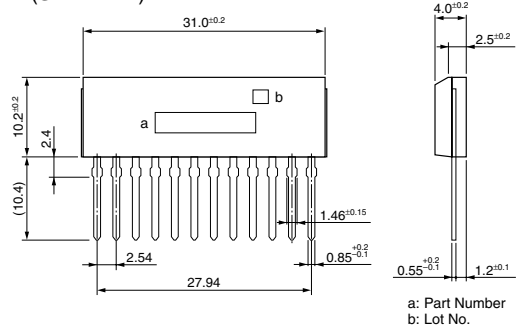

• SIP 15 (SMA15Pin)

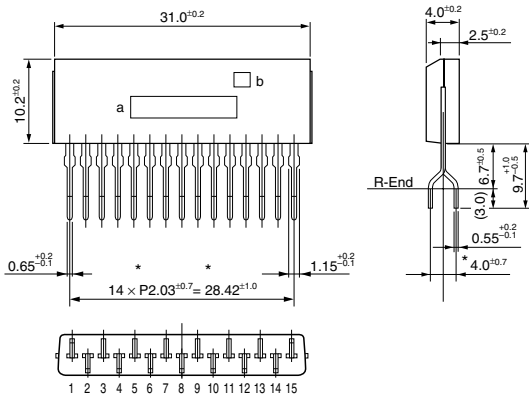

• SIP 12 with Fin (SLA12Pin)

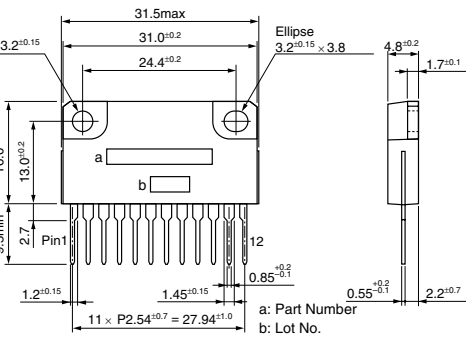

• SIP 15 with Fin (SLA15Pin)

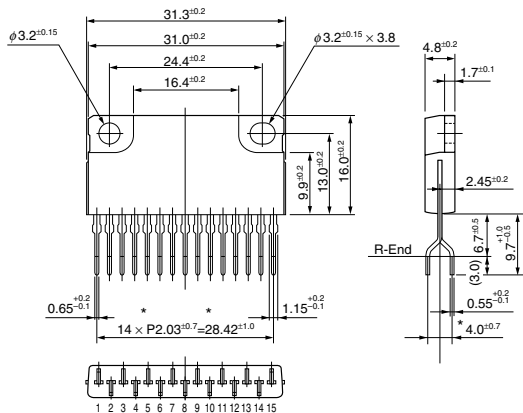

• SIP 21 with Fin (SLA21Pin)

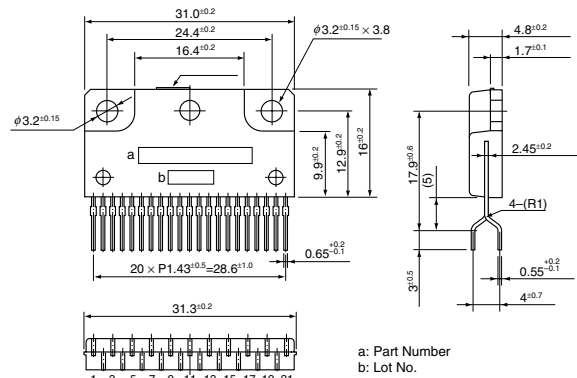

(Unit:mm)