



Chipsmall Limited consists of a professional team with an average of over 10 year of expertise in the distribution of electronic components. Based in Hongkong, we have already established firm and mutual-benefit business relationships with customers from,Europe,America and south Asia,supplying obsolete and hard-to-find components to meet their specific needs.

With the principle of “Quality Parts,Customers Priority,Honest Operation,and Considerate Service”,our business mainly focus on the distribution of electronic components. Line cards we deal with include Microchip,ALPS,ROHM,Xilinx,Pulse,ON,Everlight and Freescale. Main products comprise IC,Modules,Potentiometer,IC Socket,Relay,Connector.Our parts cover such applications as commercial,industrial, and automotives areas.

We are looking forward to setting up business relationship with you and hope to provide you with the best service and solution. Let us make a better world for our industry!



Contact us

Tel: +86-755-8981 8866 Fax: +86-755-8427 6832

Email & Skype: info@chipsmall.com Web: www.chipsmall.com

Address: A1208, Overseas Decoration Building, #122 Zhenhua RD., Futian, Shenzhen, China





SLDM-06D1Ax

Non-Isolated DC-DC Converter

The SLDM-06D1Ax power modules are non-isolated dc-dc converters that can deliver up to 6 A of output current. These modules operate over a wide range of input voltage ($V_{IN} = 3 \text{ Vdc} - 14.4 \text{ Vdc}$) and provide a precisely regulated output voltage from 0.45 Vdc to 5.5 Vdc, programmable via an external resistor and PMBus control.

Features include a digital interface using the PMBus protocol, remote On/Off, adjustable output voltage, over current and over temperature protection in the controller. The PMBus interface supports a range of commands to both control and monitor the module.

The module also includes the Tunable Loop™ feature that allows the user to optimize the dynamic response of the converter to match the load with reduced amount of output capacitance leading to savings on cost and PWB area.

Key Features & Benefits

- 3-14.4 VDC Input / 0.45-5.5 VDC @ 6 A Output
- Non-Isolated
- DOSA approved footprint
- Power Good Signal
- Remote On/Off
- Digital interface through the PMBus™ protocol
- Ability to Sink and Source Current
- Output Over Current Protection (non-latching)
- Over Temperature Protection
- Small size: 20.32 mm x 11.43 mm x 2.8 mm (Max) (0.8 in x 0.45 in x 0.11 in)
- Ultra low height design for very dense power applications.
- Output voltage programmable from 0.6Vdc to 5.5Vdc via external resistor.
- Digitally adjustable down to 0.45Vdc
- Digital interface through the PMBus™ protocol
- Flexible output voltage sequencing EZ-SEQUENCE
- Fixed switching frequency with capability of external synchronization
- Tunable Loop™ to optimize dynamic output voltage response



bel POWER
SOLUTIONS &
PROTECTION

a bel group

belpowersolutions.com

Key Features & Benefits (Continued)

- Wide operating temperature range [-40°C to 105°C].
- Compliant to IPC-9592 (September 2008), Category 2, Class II
- ISO 9001 and ISO 14001 certified manufacturing facilities
- Compliant to RoHS II EU "Directive 2011/65/EU"
- Compliant to REACH Directive (EC) No 1907/2006
- Compatible in a Pb-free or SnPb reflow environment
- UL 60950-1 Recognized, CSA C22.2 No. 60950-1-03 Certified
- VDE 0805:2001-12 (EN60950-1) Licensed

Applications

- Distributed power architectures
- Intermediate bus voltage applications
- Telecommunications equipment
- Servers and storage applications
- Networking equipment
- Industrial equipment

1. MODEL SELECTION

MODEL NUMBER	OUTPUT VOLTAGE	INPUT VOLTAGE	MAX. OUTPUT CURRENT	MAX. OUTPUT POWER	TYPICAL EFFICIENCY
SLDM-06D1A0	0.45-5.5 VDC	3-14.4 VDC	6A	33 W	91.5%
SLDM-06D1AL	0.45-5.5 VDC	3-14.4 VDC	6A	33 W	91.5%

- NOTE:** 1. Add "R" suffix at the end of the model number to indicate tape and reel packaging (Standard).
2. Add "G" suffix at the end of the model number to indicate tray packaging (Option).

PART NUMBER EXPLANATION

S	LDM	-	06	D	1A	x	Y
Mounting Type	RoHS Status	Output Current	Wide input voltage range	Output Voltage	Enable		Package Type
Surface mount	Series code	6 A	3-14.4V	With sequencing	L – active Low 0 – active High		G – Tray package R –tape and reel packaging

2. ABSOLUTE MAXIMUM RATINGS

PARAMETER	DESCRIPTION	MIN	TYP	MAX	UNITS
Continuous non-operating Input Voltage		-0.3	-	15	V
Voltage on SEQ SYNC VS+		-	-	7	V
Voltage on CLK DATA SMBALERT terminal		-	-	3.6	V
Ambient temperature	See Thermal Considerations section	-40	-	105	°C
Storage Temperature		-55	-	125	°C
Altitude		-	-	2000	m

NOTE: Stresses in excess of the absolute maximum ratings can cause permanent damage to the device. These are absolute stress ratings only, functional operation of the device is not implied at these or any other conditions in excess of those given in the operations sections of the data sheet. Exposure to absolute maximum ratings for extended periods can adversely affect the device reliability.

3. INPUT SPECIFICATIONS

All specifications are typical at 25°C unless otherwise stated.

PARAMETER	DESCRIPTION	MIN	TYP	MAX	UNIT
Operating Input Voltage		3	-	14.4	V
Input Current (full load)	V _{IN} =3V to 14V, I _O =I _{Omax}	-	-	6	A
Input Current (no load)	V _O =0.6V V _O =5V V _{IN} = 12Vdc, I _O = 0, module enabled	-	31.3 178.7	-	mA mA
Input Stand-by Current	V _{IN} = 12.0Vdc, module disabled	-	11	-	mA
Input Reflected Ripple Current (pk-pk)	5Hz to 20MHz, 1µH source impedance; V _{IN} = 0 to 14V, I _O = I _{Omax} 2. See Test Configurations	-	37.6	-	mA
I _{pt} Inrush Current Transient		-	-	1	A2s
Input Ripple Rejection (120Hz)		-	-55	-	dB

CAUTION: This converter is not internally fused. An input line fuse must be used in application.

This power module can be used in a wide variety of applications, ranging from simple standalone operation to an integrated part of sophisticated power architecture. To preserve maximum flexibility, internal fusing is not included; however, to achieve maximum safety and system protection, always use an input line fuse. The safety agencies require a fast-acting fuse with a maximum rating of 6A. Based on the information provided in this data sheet on inrush energy and maximum dc input current, the same type of fuse with a lower rating can be used. Refer to the fuse manufacturer's data sheet for further information.

Note: Unless otherwise indicated, specifications apply over all operating input voltage, resistive load, and temperature conditions.



Asia-Pacific
+86 755 298 85888

Europe, Middle East
+353 61 225 977

North America
+1 408 785 5200

4. OUTPUT SPECIFICATIONS

All specifications are typical at nominal input, full load at 25°C unless otherwise stated.

PARAMETER		DESCRIPTION	MIN	TYP	MAX	UNIT
Output Voltage Set Point		with 0.1% tolerance for external resistor used to set output voltage	-1.0	-	1.0	%Vo,set
Output Voltage		Over all operating input voltage, resistive load, and temperature conditions until end of life	-0.3	-	0.3	%Vo,set
PMBus Adjustable Output Voltage Range			-25	-	25	%Vo,set
PMBus Output Voltage Adjustment Step Size			0.4	-	-	%Vo,set
Adjustment Range		1. Some output voltages may not be possible depending on the input voltage – see Feature Descriptions Section 2. Selected by an external resistor.	0.6	-	5.5	V
Remote Sense Range			-	-	0.5	V
Load Regulation	$V_O \geq 2.5V$	$I_O = I_{O, \min}$ to $I_{O, \max}$	-	-	10	mV
	$V_O < 2.5V$		-	-	10	mV
Line Regulation	$V_O \geq 2.5V$	$V_{IN} = V_{IN, \min}$ to $V_{IN, \max}$	-	-	0.4	%Vo,set
	$V_O < 2.5V$		-	-	5	mV
Temperature Regulation		$T_{ref} = T_{A, \min}$ to $T_{A, \max}$	-	-	0.4	%Vo,set
Ripple and Noise(Pk-Pk)		5Hz to 20MHz BW, $V_{IN} = V_{IN, \text{nom}}$ and $I_O = I_{O, \min}$ to $I_{O, \max}$, $C_O = 0.1\mu F // 22\mu F$ ceramic capacitors)	-	50	100	mV
Ripple and Noise(RMS)			-	20	38	mV
Output Current Range		in either sink or source mode	0	-	6	A
Output Current Limit Inception		Current limit does not operate in sink mode	-	130	-	%Io,max
Output Short-Circuit Current		$V_O \leq 250mV$, Hiccup Mode	-	1.3	-	Arms
Output Capacitance	$ESR \geq 1\ m\Omega$	Without the Tunable Loop™	1x47	-	2x47	μF
	$ESR \geq 0.15\ m\Omega$	With the Tunable Loop™	2x47	-	1000	μF
	$ESR \geq 10\ m\Omega$	With the Tunable Loop™	2x47	-	5000	μF
Turn-On Delay Times ($V_{IN} = V_{IN, \text{nom}}$, $I_O = I_{O, \max}$, V_O to within $\pm 1\%$ of steady state)		Case 1: On/Off input is enabled and then input power is applied (delay from instant at which $V_{IN} = V_{IN, \min}$ until $V_O = 10\%$ of $V_{O, \text{set}}$)	-	0.4	-	ms
		Case 2: Input power is applied for at least one second and then the On/Off input is enabled (delay from instant at which Von/Off is enabled until $V_O = 10\%$ of $V_{O, \text{set}}$)	-	0.8	-	ms

- Notes:**
1. Some output voltages may not be possible depending on the input voltage.
 2. External capacitors may require using the new Tunable Loop™ feature to ensure that the module is stable as well as getting the best transient response (See the Tunable Loop™ section for details).
 3. Unless otherwise indicated, specifications apply over all operating input voltage, resistive load, and temperature conditions.

5. GENERAL SPECIFICATIONS

PARAMETER	DESCRIPTION	MIN	TYP	MAX	UNIT
Efficiency	Vo=0.6V		72.6		%
	Vo=1.2V		82.5		
	Vo=1.8V		86.1		
	Vo=2.5V	-	88.0	-	
	Vo=3.3V		89.4		
	Vo=5.0V		91.5		
Switching Frequency	Vin= 12Vdc, Ta=25°C Io=Io, max, Vo= Vo,set	-	800	-	kHz
Synchronization Frequency Range		760	800	840	kHz
High-Level Input Voltage		2.0	-	-	V
Low-Level Input Voltage		-	-	0.4	V
Input Current, SYNC		-	-	100	nA
Minimum Pulse Width, SYNC		100	-	-	ns
Maximum SYNC rise time		100	-	-	ns
Over Temperature Protection		-	130	-	°C
PMBus Over Temperature Warning Threshold		-	120	-	°C
PMBus Adjustable Input Under Voltage Lockout Thresholds		2.5	-	14	V
Resolution of Adjustable Input Under Voltage Threshold		-	-	500	mV
Input Undervoltage Lockout Turn-on Threshold		2.475	-	3.025	V
Turn-off Threshold		2.25	-	2.75	V
Hysteresis		-	0.25	-	V
Tracking Accuracy		-	-	100	mV
Power-Up: 2V/ms	Vin, min to Vin, max; Io, min to Io, max, Vseq < Vo	-	-	100	mV
Power-Down: 2V/ms		-	-	100	mV
PGOOD (Power Good)					
Overvoltage threshold for PGOOD ON		-	108	-	%Vo,set
Overvoltage threshold for PGOOD OFF		-	110	-	%Vo,set
Undervoltage threshold for PGOOD ON	Signal Interface Open Drain, Vsupply ≤ 5Vdc	-	92	-	%Vo,set
Undervoltage threshold for PGOOD OFF		-	90	-	%Vo,set
Pulldown resistance of PGOOD pin		-	-	50	Ω
Sink current capability into PGOOD pin		-	-	5	mA
Weight		-	1.186	-	g
MTBF	Calculated MTBF (IO=0.8IO, max, TA=40°C) Telecordia Issue 2 Method 1 Case 3		77,807,049		hours
Dimensions					
Inches (L × W × H)			0.8 x 0.45 x 0.11		Inches
Millimeters (L × W × H)			20.32 x 11.43 x 2.8		Millimeters

Note: Unless otherwise indicated, specifications apply over all operating input voltage, resistive load, and temperature conditions.



Asia-Pacific
+86 755 298 85888

Europe, Middle East
+353 61 225 977

North America
+1 408 785 5200

6. DIGITAL INTERFACE SPECIFICATIONS

PARAMETER	DESCRIPTION	MIN	TYP	MAX	UNIT
PMBus Signal Interface Characteristics					
Input High Voltage (CLK, DATA)		2.1	-	3.6	V
Input Low Voltage (CLK, DATA)		-	-	0.8	V
Input high level current (CLK, DATA)		-10	-	10	uA
Input low level current (CLK, DATA)		-10	-	10	uA
Output Low Voltage (CLK, DATA, SMBALERT#)	$I_{out} = 2\text{mA}$	-	-	0.4	V
Output high level open drain leakage current (DATA, SMBALERT#)	$V_{out} = 3.6\text{V}$	0	-	10	uA
Pin capacitance		-	0.7	-	pF
PMBus Operating frequency range		10	-	400	KHZ
Data setup time		250	-	-	ns
Data hold time	<u>Receive Mode</u> <u>Transmit Mode</u>	<u>0</u> <u>300</u>	-	-	ns
Measurement System Characteristics					
Read delay time		153	192	231	us
Output current measurement range		0	-	9	A
Output current measurement resolution		62.5	-	-	mA
Output current measurement gain accuracy		-	-	± 5	%
Output current measurement offset		-	-	0.1	A
V_{OUT} measurement range		0	-	5.5	V
V_{OUT} measurement resolution		-	15.625	-	mA
V_{OUT} measurement gain accuracy		-15	-	15	%
V_{OUT} measurement offset		-3	-	3	%
V_{IN} measurement range		3	-	14.4	V
V_{IN} measurement resolution		-	32.5	-	mV
V_{IN} measurement gain accuracy		-15	-	15	%
V_{IN} measurement offset		-5.5	-	1.4	LSB

7. EFFICIENCY DATA

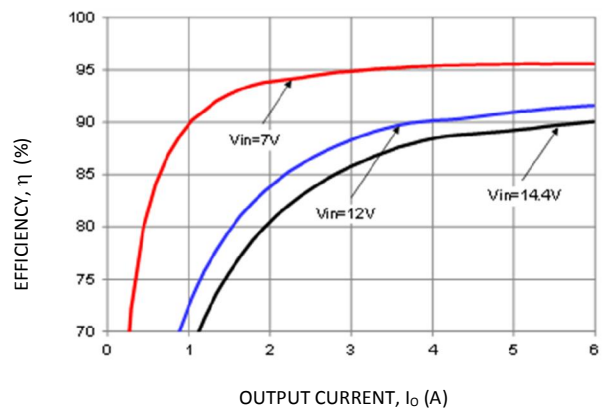
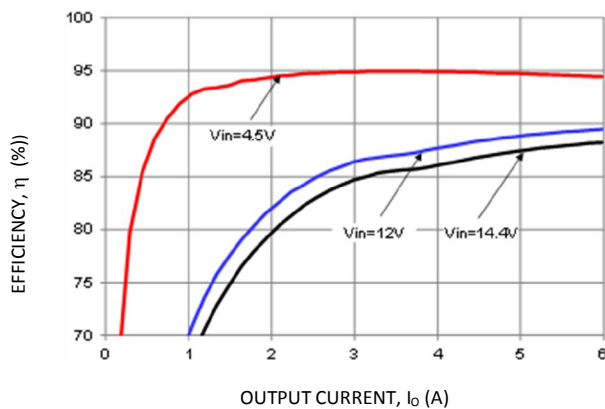
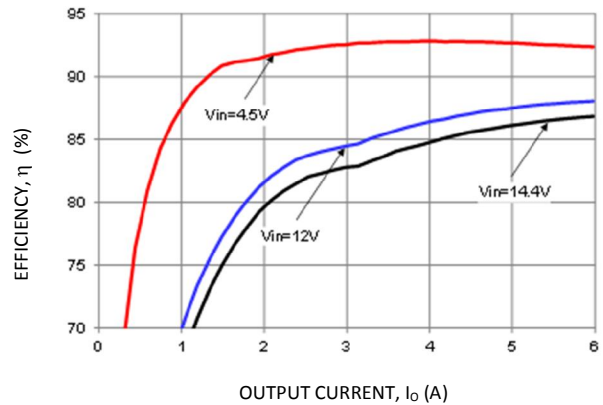
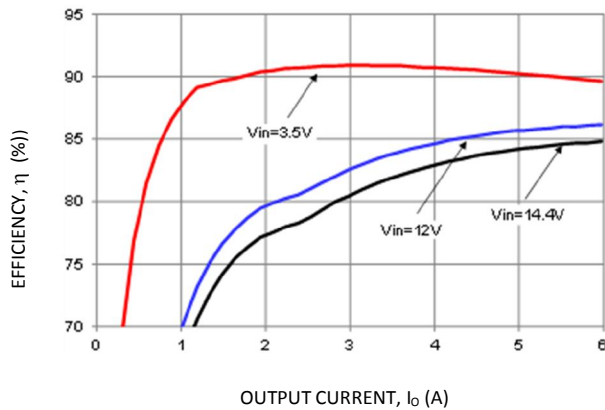
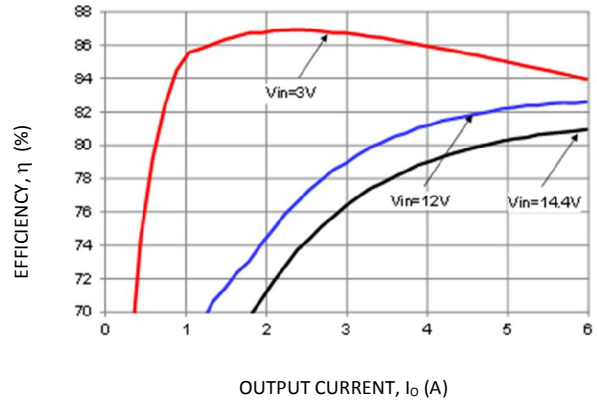
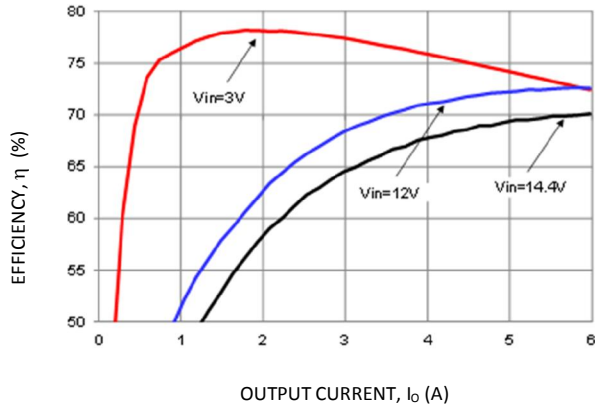

8. THERMAL DERATING CURVE

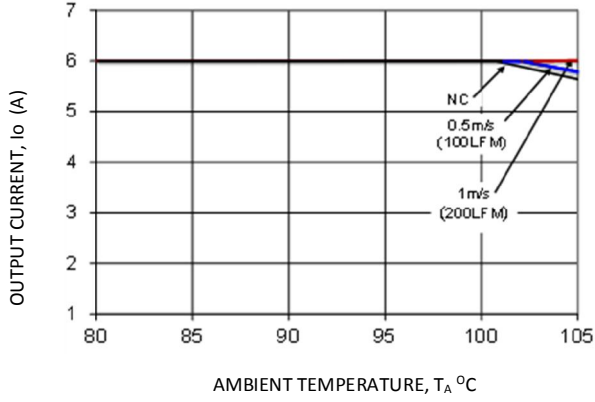

Vo=0.6V

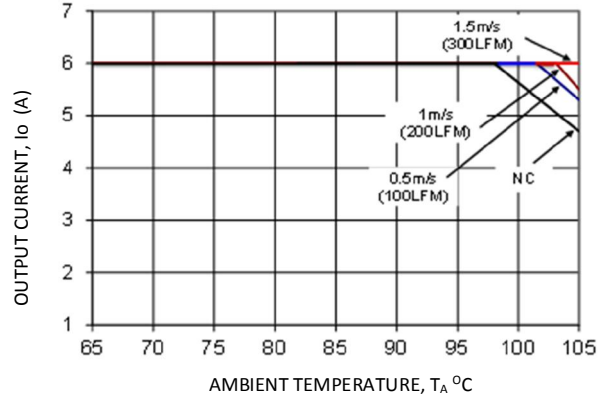

Vo=1.2V

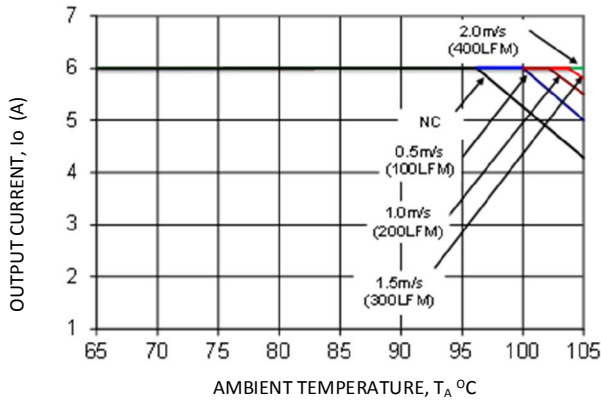

Vo=1.8V

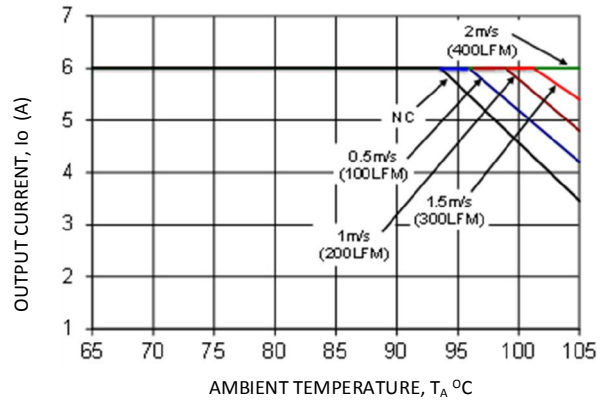

Vo=2.5V

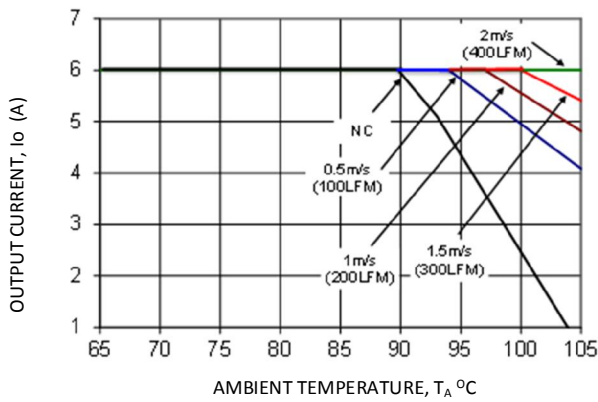

Vo=3.3V

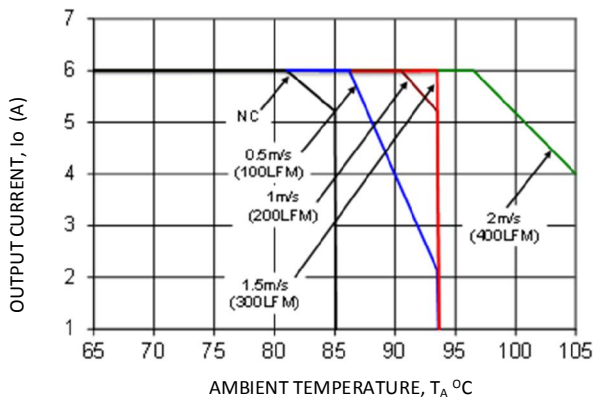

Vo=5.0V

9. RIPPLE AND NOISE WAVEFORMS

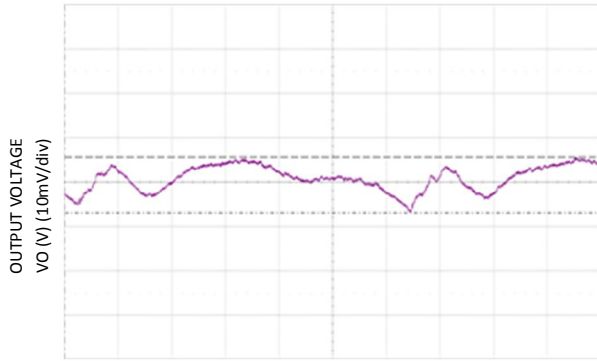

TIME, t (200ns/div)
 $V_o=0.6V, I_o = I_{o,max}$

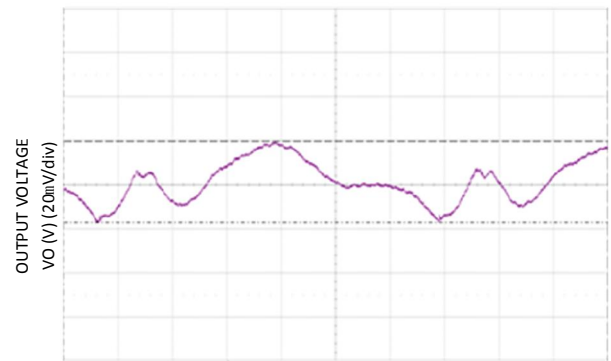

TIME, t (200ns/div)
 $V_o=1.2V, I_o = I_{o,max}$

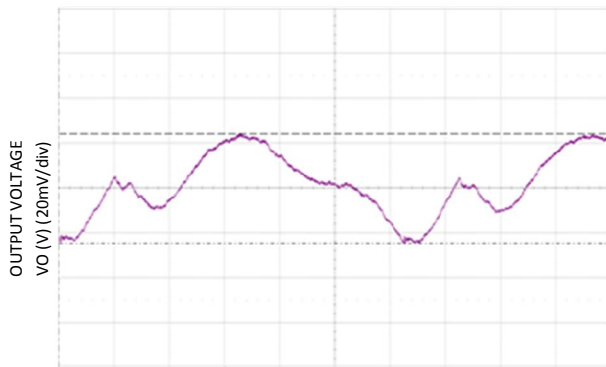

TIME, t (200ns/div)
 $V_o=1.8V, I_o = I_{o,max}$

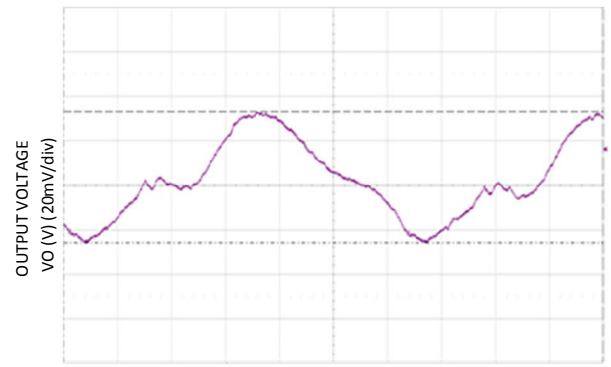

TIME, t (200ns/div)
 $V_o=2.5V, I_o = I_{o,max}$

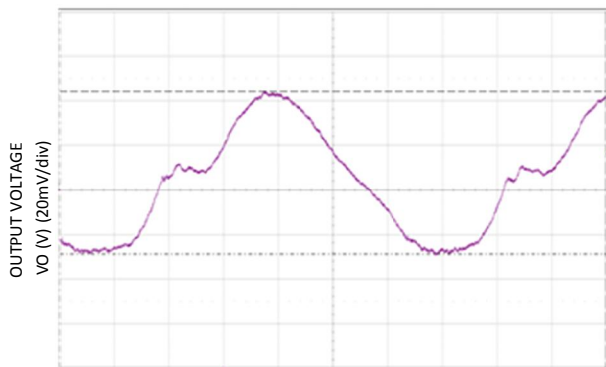

TIME, t (200ns/div)
 $V_o=3.3V, I_o = I_{o,max}$

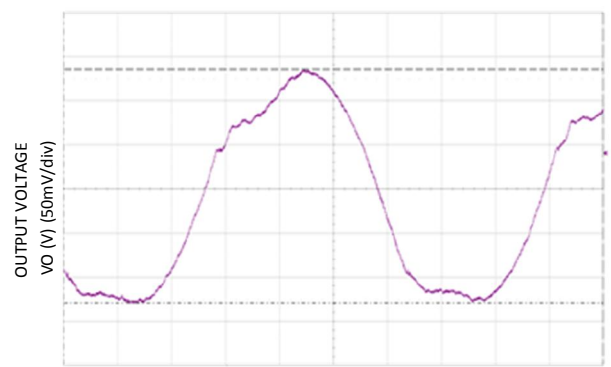

TIME, t (200ns/div)
 $V_o=5.0V, I_o = I_{o,max}$

Notes: Co=1x47uF ceramic, VIN= 12V, Io = Io,max

10. TRANSIENT RESPONSE WAVEFORMS

Note: Transient Response to Dynamic Load Change from 50% to 100% at 12Vin

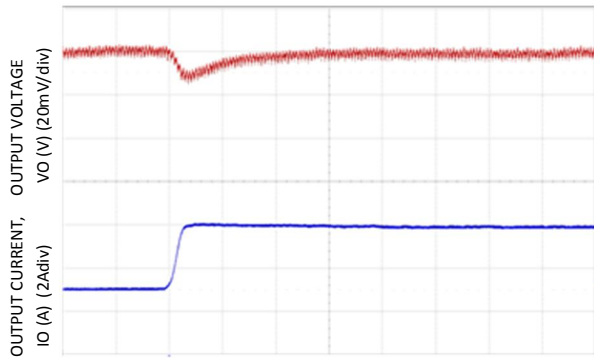

TIME, t (20µs /div)

$V_o=0.6V$, $C_{out}=3x47\mu F+3x330\mu F$, $C_{Tune}=15nF$, $R_{Tune}=200\Omega$

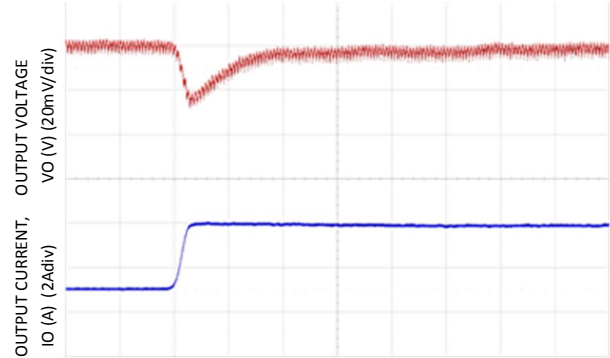

TIME, t (20µs /div)

$V_o=1.2V$, $C_{out}=3x47\mu F+1x330\mu F$, $C_{Tune}=4700pF$, $R_{Tune}=300\Omega$

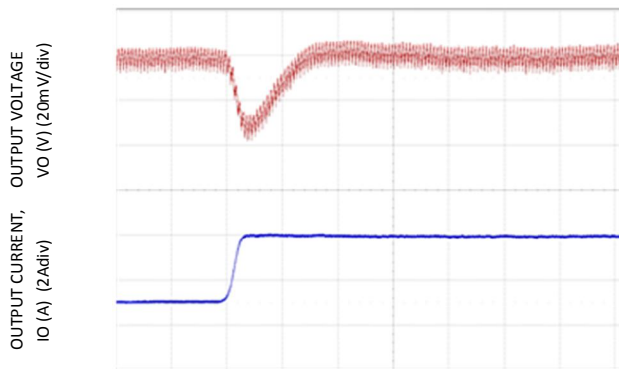

TIME, t (20µs /div)

$V_o=1.8V$, $C_{out}=2x47\mu F+1x330\mu F$, $C_{Tune}=2700pF$, $R_{Tune}=300\Omega$

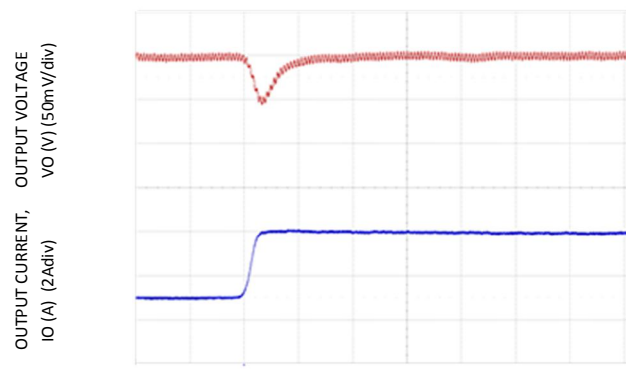

TIME, t (20µs /div)

$V_o=2.5V$, $C_{out}=4x47\mu F$, $C_{Tune}=2700pF$, $R_{Tune}=300\Omega$

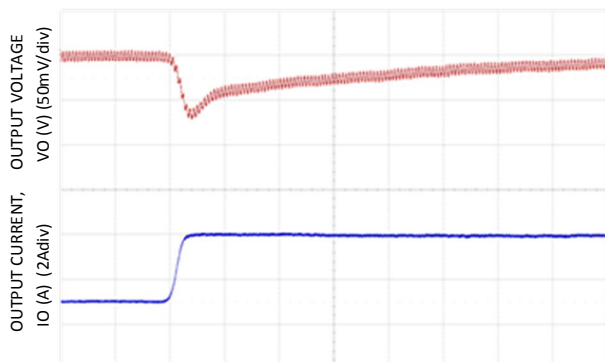

TIME, t (20µs /div)

$V_o=3.3V$, $C_{out}=4x47\mu F$, $C_{Tune}=2700pF$, $R_{Tune}=300\Omega$

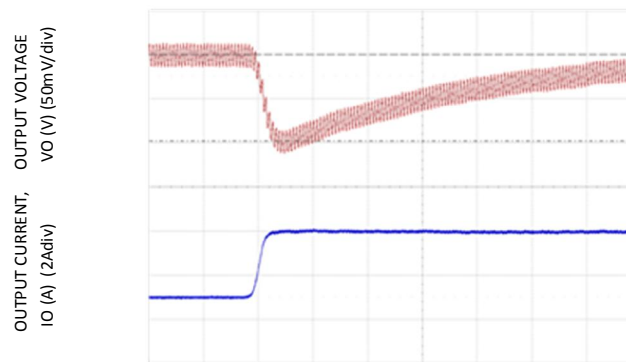

TIME, t (20µs /div)

$V_o=5.0V$, $C_{out}=3x47\mu F$, $C_{Tune}=1500pF$, $R_{Tune}=300\Omega$

11. STARTUP TIME

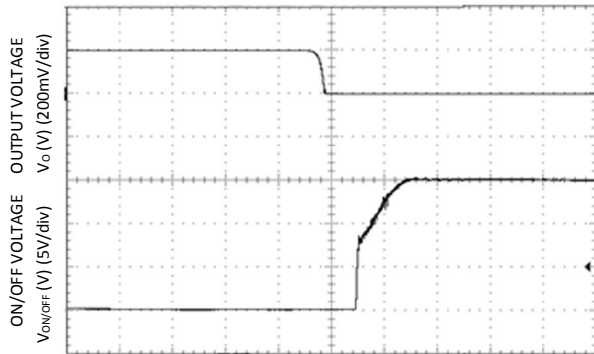

TIME, t (2 ms/div)

Start-up Using On/Off Voltage ($I_o = I_{o,max}$), $V_o=0.6V$

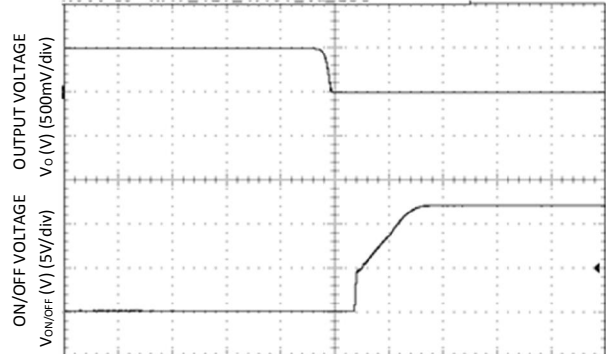

TIME, t (2 ms/div)

Start-up Using On/Off Voltage ($I_o = I_{o,max}$), $V_o=1.2V$

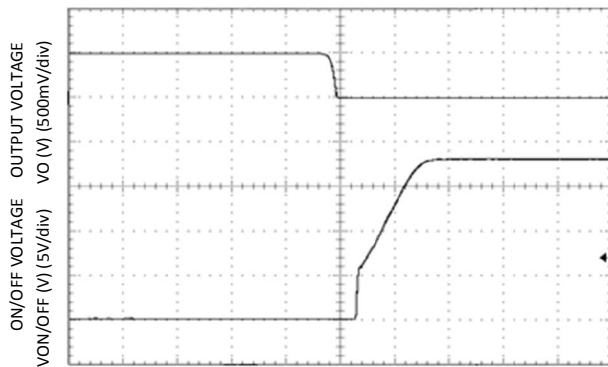

TIME, t (2 ms/div)

Start-up Using On/Off Voltage ($I_o = I_{o,max}$), $V_o=1.8V$

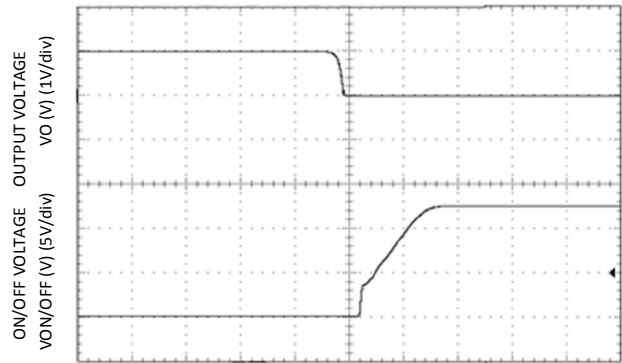

TIME, t (2 ms/div)

Start-up Using On/Off Voltage ($I_o = I_{o,max}$), $V_o=2.5V$

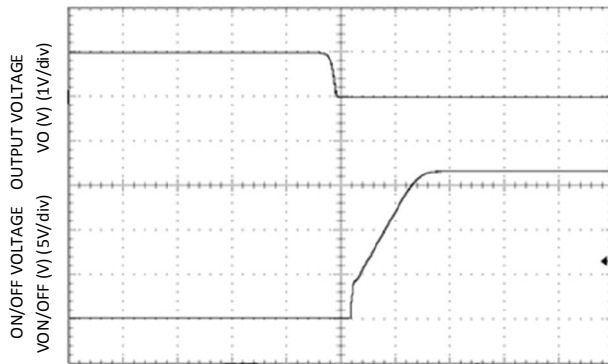

TIME, t (2 ms/div)

Start-up Using On/Off Voltage ($I_o = I_{o,max}$), $V_o=3.3V$

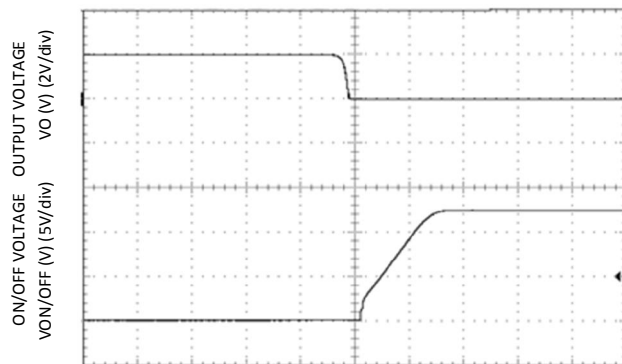

TIME, t (2 ms/div)

Start-up Using On/Off Voltage ($I_o = I_{o,max}$), $V_o=5.0V$

STARTUP TIME(CONTINUED)

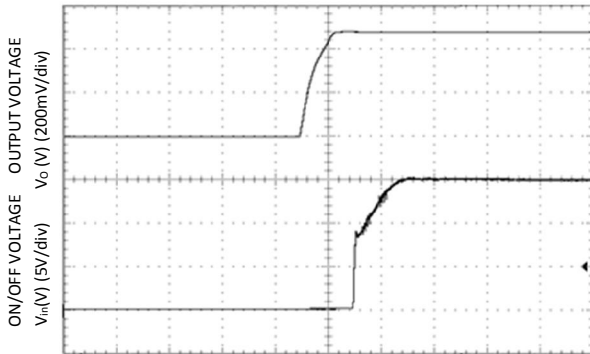

TIME, t (2 ms/div)

Start-up Using Input Voltage ($V_{IN} = 12V, I_o = I_{o,max}$), $V_o = 0.6V$

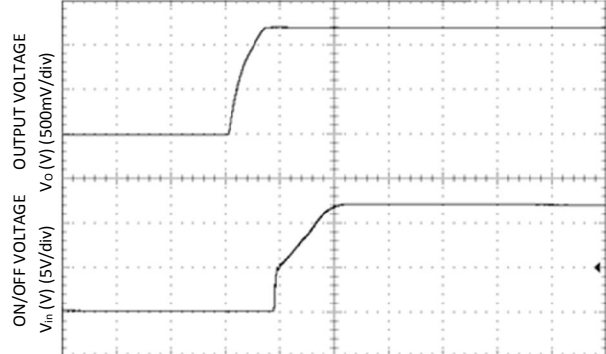

TIME, t (2 ms/div)

Start-up Using Input Voltage ($V_{IN} = 12V, I_o = I_{o,max}$), $V_o = 1.2V$

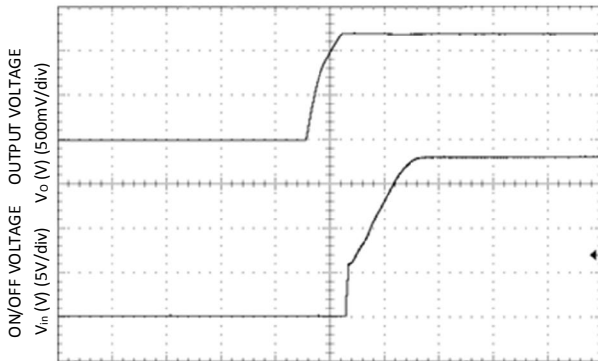

TIME, t (2 ms/div)

Start-up Using Input Voltage ($V_{IN} = 12V, I_o = I_{o,max}$), $V_o = 1.8V$

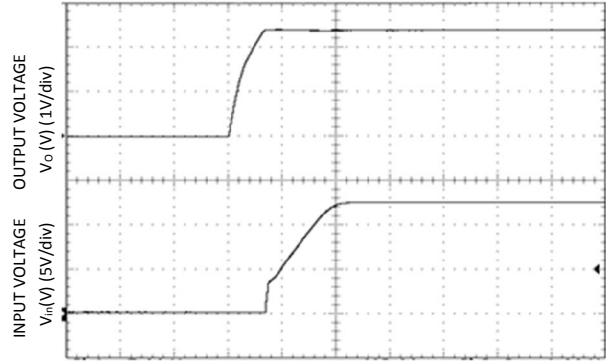

TIME, t (2 ms/div)

Start-up Using Input Voltage ($V_{IN} = 12V, I_o = I_{o,max}$), $V_o = 2.5V$

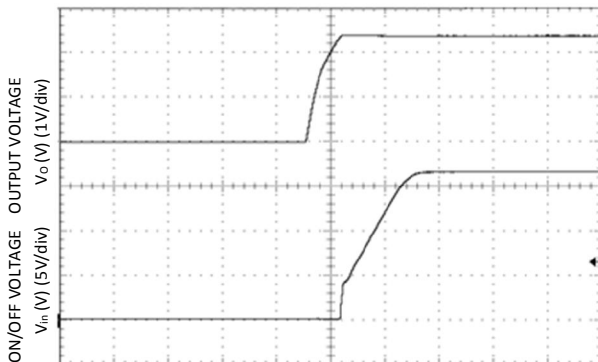

TIME, t (2 ms/div)

Start-up Using Input Voltage ($V_{IN} = 12V, I_o = I_{o,max}$), $V_o = 3.3V$

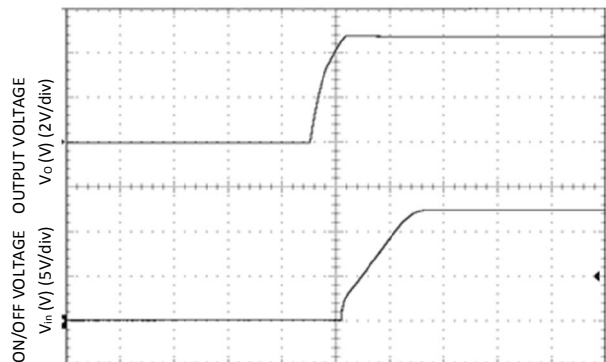

TIME, t (2 ms/div)

Start-up Using Input Voltage ($V_{IN} = 12V, I_o = I_{o,max}$), $V_o = 5.0V$

12. INPUT FILTERING

The SLDM-06D1Ax module should be connected to a low ac-impedance source. A highly inductive source can affect the stability of the module. An input capacitance must be placed directly adjacent to the input pin of the module, to minimize input ripple voltage and ensure module stability.

To minimize input voltage ripple, ceramic capacitors are recommended at the input of the module. Figure 37 shows the input ripple voltage for various output voltages at 6A of load current with 1x22 μ F or 2x22 μ F ceramic capacitors and an input of 12V.

Figure 37

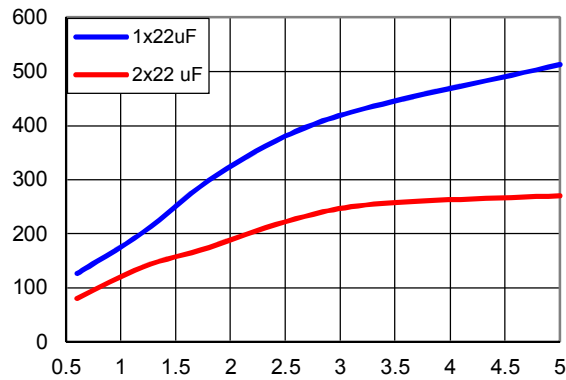

Note: Input ripple voltage for various output voltages with 1x22 μ F or 2x22 μ F ceramic capacitors at the input (6A load). Input voltage is 12V.

13. OUTPUT FILTERING

These modules are designed for low output ripple voltage and will meet the maximum output ripple specification with suggested $2 \times 0.047 \mu\text{F} + 1 \times 1 \mu\text{F}$ ceramic decoupling capacitors and $1 \times 47 \mu\text{F}$ ceramic capacitors at the output of the module. However, additional output filtering may be required by the system designer for a number of reasons. First, there may be a need to further reduce the output ripple and noise of the module. Second, the dynamic response characteristics may need to be customized to a particular load step change.

To reduce the output ripple and improve the dynamic response to a step load change, additional capacitance at the output can be used. Low ESR polymer and ceramic capacitors are recommended to improve the dynamic response of the module. Figure 38 provides output ripple information, measured with a scope with its Bandwidth limited to 20MHz for different external capacitance values at various V_o and a full load current of 6A. For stable operation of the module, limit the capacitance to less than the maximum output capacitance as specified in the electrical specification table. Optimal performance of the module can be achieved by using the Tunable Loop™ feature described later in this data sheet.

Figure 38

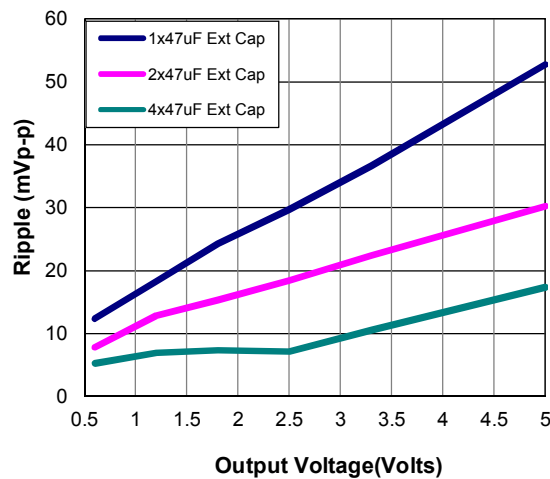

Note: Output ripple voltage for various output voltages with external $2 \times 47 \mu\text{F}$, $4 \times 47 \mu\text{F}$, $6 \times 47 \mu\text{F}$ or $8 \times 47 \mu\text{F}$ ceramic capacitors at the output (6A load). Input voltage is 12V.

14. SAFETY CONSIDERATIONS

For safety agency approval the power module must be installed in compliance with the spacing and separation requirements of the end-use safety agency standards, i.e., UL 60950-1 2nd, CSA C22.2 No. 60950-1-07, DIN EN 60950-1:2006 + A11 (VDE0805 Teil 1 + A11):2009-11; EN 60950-1:2006 + A11:2009-03.

For the converter output to be considered meeting the requirements of safety extra-low voltage (SELV), the input must meet SELV requirements. The power module has extra-low voltage (ELV) outputs when all inputs are ELV.

The input to these units is to be provided with a fast acting fuse (for example, Bel Fuse SMM series) with a maximum rating of 20 A in the positive input lead.

15. REMOTE ON/OFF

PARAMETER		DESCRIPTION	MIN	TYP	MAX	UNIT
Signal Low (Unit On)	Active Low	The remote on/off pin open, Unit on.	-0.2	-	0.6	V
Signal High (Unit Off)			2.0	-	V _{in,max}	V
Signal Low (Unit Off)	Active High	The remote on/off pin open, Unit on.	-0.2	-	0.6	V
Signal High (Unit On)			2.0	-	V _{in,max}	V

The module can be turned ON and OFF either by using the ON/OFF pin (Analog interface) or through the PMBus interface (Digital). The module can be configured in a number of ways through the PMBus interface to react to the two ON/OFF inputs:

Module ON/OFF can be controlled only through the analog interface (digital interface ON/OFF commands are ignored).

Module ON/OFF can be controlled only through the PMBus interface (analog interface is ignored).

Module ON/OFF can be controlled by either the analog or digital interface.

The default state of the module (as shipped from the factory) is to be controlled by the analog interface only. If the digital interface is to be enabled, or the module is to be controlled only through the digital interface, this change must be made through the PMBus. These changes can be made and written to non-volatile memory on the module so that it is remembered for subsequent use.

16. ANALOG ON/OFF

The SLDM-06D1Ax power modules feature an On/Off pin for remote On/Off operation. Two On/Off logic options are available. In the Positive Logic On/Off option, (device code suffix "0" – see Ordering Information), the module turns ON during a logic High on the On/Off pin and turns OFF during a logic Low. With the Negative Logic On/Off option, (device code suffix "L" – see Ordering Information), the module turns OFF during logic High and ON during logic Low. The On/Off signal should be always referenced to ground. For either On/Off logic option, leaving the On/Off pin disconnected will turn the module ON when input voltage is present.

For positive logic modules, the circuit configuration for using the On/Off pin is shown in Figure 39. When the external transistor Q2 is in the OFF state, the internal transistor Q7 is turned ON, which turn Q3 OFF which keeps Q6 OFF and Q5 OFF. This allows the internal PWM #Enable signal to be pulled up by the internal 3.3V, thus turning the module ON. When transistor Q2 is turned ON, the On/Off pin is pulled low, which turns Q7 OFF which turns Q3, Q6 and Q5 ON and the internal PWM #Enable signal is pulled low and the module is OFF. A suggested value for Rpullup is 20kΩ.

For negative logic On/Off modules, the circuit configuration is shown in Fig. 40. The On/Off pin should be pulled high with an external pull-up resistor (suggested value for the 3V to 14V input range is 20Kohms). When transistor Q2 is in the OFF state, the On/Off pin is pulled high, transistor Q3 is turned ON. This turns Q6 ON, followed by Q5 turning ON which pulls the internal ENABLE low and the module is OFF. To turn the module ON, Q2 is turned ON pulling the On/Off pin low, turning transistor Q3 OFF, which keeps Q6 and Q5 OFF resulting in the PWM Enable pin going high.

Figure 39

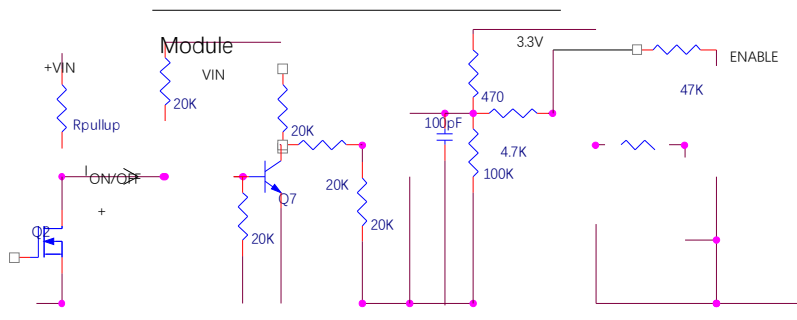

Circuit configuration for using positive On/Off logic

Figure 40

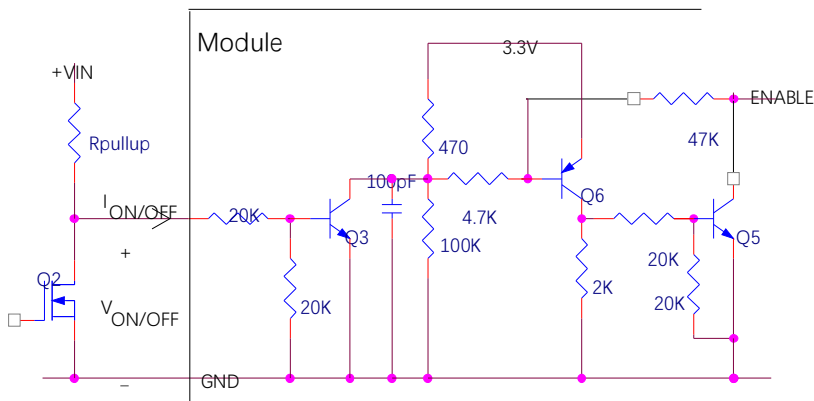

Circuit configuration for using negative On/Off logic

17. DIGITAL ON/OFF

Please see the Digital Feature Descriptions section.

18. MONOTONIC START-UP AND SHUTDOWN

The SLDM-06D1Ax module has monotonic start-up and shutdown behavior for any combination of rated input voltage, output current and operating temperature range.

19. STARTUP INTO PRE-BIASED OUTPUT

The SLDM-06D1Ax module can start into a prebiased output as long as the prebias voltage is 0.5V less than the set output voltage.

20. OUTPUT VOLTAGE PROGRAMMING

The output voltage of the module is programmable to any voltage from 0.6Vdc to 5.5Vdc by connecting a resistor between the Trim and SIG_GND pins of the module. Certain restrictions apply on the output voltage set point depending on the input voltage. These are shown in the Output Voltage vs. Input Voltage Set Point Area plot in Fig. 41. The Upper Limit curve shows that for output voltages lower than 1V, the input voltage must be lower than the maximum of 14.4V. The Lower Limit curve shows that for output voltages higher than 0.6V, the input voltage needs to be larger than the minimum of 3V.

Figure 41

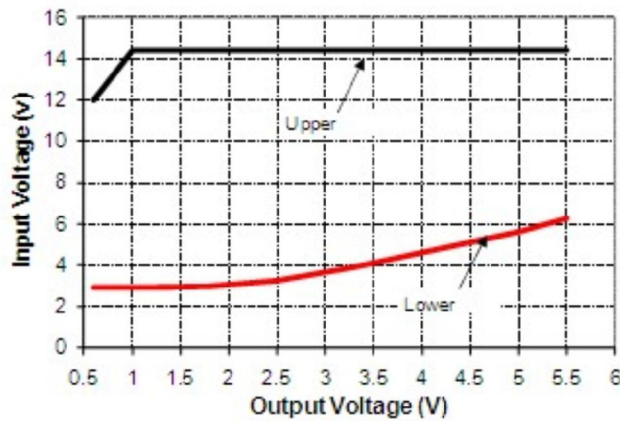

Output Voltage vs. Input Voltage Set Point Area plot showing limits where the output voltage can be set for different input voltages.

Figure 42

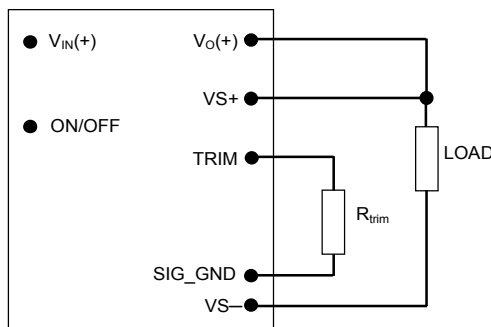

Caution : Do not connect SIG_GND to GND elsewhere in the layout
Circuit configuration for programming output voltage using an external resistor.

21. OUTPUT TRIM EQUATIONS

Without an external resistor between Trim and SIG_GND pins, the output of the module will be 0.6Vdc. To calculate the value of the trim resistor, Rtrim for a desired output voltage, should be as per the following equation:

$$R_{trim} = \left[\frac{12}{(V_o - 0.6)} \right] k\Omega$$

Rtrim is the external resistor in KΩ
Vo is the desired output voltage.

Table 1 provides Rtrim values required for some common output voltages.

Table 1

VO, set (V)	Rtrim (KΩ)
0.6	Open
0.9	40
1.0	30
1.2	20
1.5	13.33
1.8	10
2.5	6.316
3.3	4.444
5.0	2.727

22. DIGITAL OUTPUT VOLTAGE ADJUSTMENT

Please see the Digital Feature Descriptions section.

23. REMOTE SENSE

The SLDM-06D1Ax power module has a Remote Sense feature to minimize the effects of distribution losses by regulating the voltage between the sense pins (VS+ and VS-). The voltage drop between the sense pins and the VOUT and GND pins of the module should not exceed 0.5V.

24. VOLTAGE MARGINING

Output voltage margining can be implemented in the module by connecting a resistor, Rmargin-up, from the Trim pin to the ground pin for margining-up the output voltage and by connecting a resistor, Rmargin-down, from the Trim pin to output pin for margining-down. Figure 43 shows the circuit configuration for output voltage margining. Please consult your local Bel Power technical representative for additional details.

Figure 43

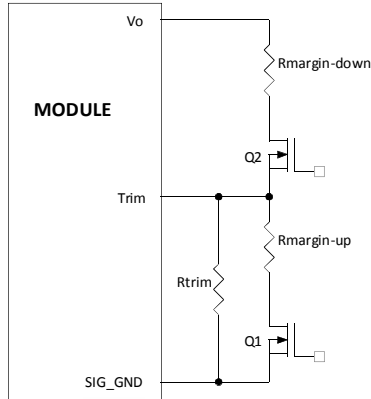

Circuit Configuration for margining Output voltage

25. DIGITAL OUTPUT VOLTAGE MARGINING

Please see the Digital Feature Descriptions section.

26. OUTPUT VOLTAGE SEQUENCING

The SLDM-06D1Ax module includes a sequencing feature, EZ-SEQUENCE that enables users to implement various types of output voltage sequencing in their applications. This is accomplished via an additional sequencing pin. When not using the sequencing feature, leave it unconnected.

The voltage applied to the SEQ pin should be scaled down by the same ratio as used to scale the output voltage down to the reference voltage of the module. This is accomplished by an external resistive divider connected across the sequencing voltage before it is fed to the SEQ pin as shown in Fig. 44. In addition, a small capacitor (suggested value 100pF) should be connected across the lower resistor R1.

For SLDM-06D1x modules, the minimum recommended delay between the ON/OFF signal and the sequencing signal is 10ms to ensure that the module output is ramped up according to the sequencing signal. This ensures that the module soft-start routine is completed before the sequencing signal is allowed to ramp up.

Figure 44

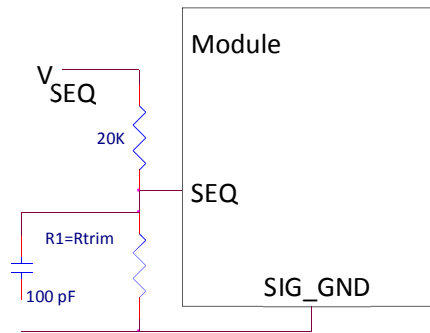

Circuit showing connection of the sequencing signal to the SEQ pin

When the scaled down sequencing voltage is applied to the SEQ pin, the output voltage tracks this voltage until the output reaches the set-point voltage. The final value of the sequencing voltage must be set higher than the set-point voltage of the module. The output voltage follows the sequencing voltage on a one-to-one basis. By connecting multiple modules together, multiple modules can track their output voltages to the voltage applied on the SEQ pin.

The module's output can track the SEQ pin signal with slopes of up to 0.5V/msec during power-up or power-down.

To initiate simultaneous shutdown of the modules, the SEQ pin voltage is lowered in a controlled manner. The output voltage of the modules tracks the voltages below their set-point voltages on a one-to-one basis. A valid input voltage must be maintained until the tracking and output voltages reach ground potential.

Note that in all digital Bel series of modules, the PMBus Output Undervoltage Fault will be tripped when sequencing is employed. This will be detected using the STATUS_WORD and STATUS_VOUT PMBus commands. In addition, the SMBALERT# signal will be asserted low as occurs for all faults and warnings. To avoid the module shutting down due to the Output Undervoltage Fault, the module must be set to continue operation without interruption as the response to this fault (see the description of the PMBus command VOUT_UV_FAULT_RESPONSE for additional information)

27. OVERCURRENT PROTECTION

To provide protection in a fault (output overload) condition, the unit is equipped with internal current-limiting circuitry and can endure current limiting continuously. At the point of current-limit inception, the unit enters hiccup mode. The unit operates normally once the output current is brought back into its specified range.

28. DIGITAL ADJUSTABLE OVERCURRENT WARNING

Please see the Digital Feature Descriptions section.

29. OVERTEMPERATURE PROTECTION

To provide protection in a fault condition, the unit is equipped with a thermal shutdown circuit. The unit will shut down if the overtemperature threshold of 150°C(typ) is exceeded at the thermal reference point Tref. Once the unit goes into thermal shutdown it will then wait to cool before attempting to restart.

30. DIGITAL TEMPERATURE STATUS VIA PMBUS

Please see the Digital Feature Descriptions section.

31. DIGITAL ADJUSTABLE OUTPUT OVER AND UNDER VOLTAGE PROTECTION

Please see the Digital Feature Descriptions section

32. INPUT UNDERVOLTAGE LOCKOUT

At input voltages below the input undervoltage lockout limit, the module operation is disabled. The module will begin to operate at an input voltage above the undervoltage lockout turn-on threshold.

33. DIGITAL ADJUSTABLE INPUT UNDERVOLTAGE LOCKOUT

Please see the Digital Feature Descriptions section

34. DIGITAL ADJUSTABLE POWER GOOD THRESHOLDS

Please see the Digital Feature Descriptions section

35. SYNCHRONIZATION

The module switching frequency can be synchronized to a signal with an external frequency within a specified range. Synchronization can be done by using the external signal applied to the SYNC pin of the module as shown in Fig. 45, with the converter being synchronized by the rising edge of the external signal. The Electrical Specifications table specifies the requirements of the external SYNC signal. If the SYNC pin is not used, the module should free run at the default switching frequency. **If synchronization is not being used, connect the SYNC pin to GND.**

Figure 45

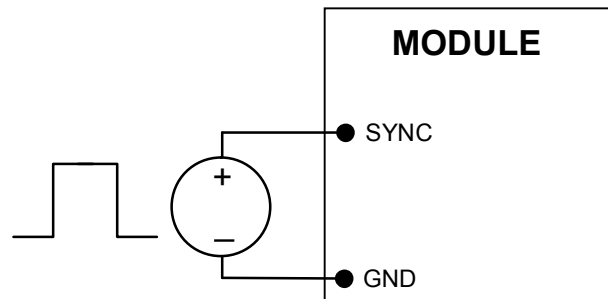

External source connections to synchronize switching frequency of the module.

36. MEASURING OUTPUT CURRENT, OUTPUT VOLTAGE AND INPUT VOLTAGE

Please see the Digital Feature Descriptions section.



37. TUNABLE LOOP™

The SLDM-06D1Ax has a feature that optimizes transient response of the module called Tunable Loop™ .

External capacitors are usually added to the output of the module for two reasons: to reduce output ripple and noise (see Figure 38) and to reduce output voltage deviations from the steady-state value in the presence of dynamic load current changes. Adding external capacitance however affects the voltage control loop of the module, typically causing the loop to slow down with sluggish response. Larger values of external capacitance could also cause the module to become unstable.

The Tunable Loop™ allows the user to externally adjust the voltage control loop to match the filter network connected to the output of the module. The Tunable Loop™ is implemented by connecting a series R-C between the VS+ and TRIM pins of the module, as shown in Fig. 46. This R-C allows the user to externally adjust the voltage loop feedback compensation of the module.

Figure 46

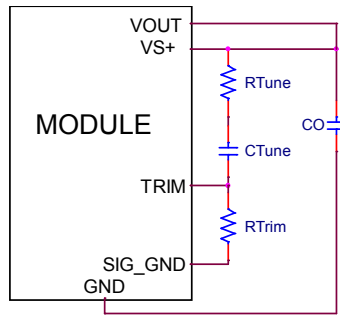

Circuit diagram showing connection of R_{TUNE} and C_{TUNE} to tune the control loop of the module

Recommended values of R_{TUNE} and C_{TUNE} for different output capacitor combinations are given in Table 2. Table 2 shows the recommended values of R_{TUNE} and C_{TUNE} for different values of ceramic output capacitors up to 1000uF that might be needed for an application to meet output ripple and noise requirements. Selecting R_{TUNE} and C_{TUNE} according to Table 2 will ensure stable operation of the module.

In applications with tight output voltage limits in the presence of dynamic current loading, additional output capacitance will be required. Table 3 lists recommended values of R_{TUNE} and C_{TUNE} in order to meet 2% output voltage deviation limits for some common output voltages in the presence of a 3A to 6A step change (50% of full load), with an input voltage of 12V.

Please contact your Bel representative to obtain more details of this feature as well as for guidelines on how to select the right value of external R-C to tune the module for best transient performance and stable operation for other output capacitance values.

Table 2

Co	3x47µF	4x47µF	6x47µF	10x47µF	20x47µF
R_{TUNE}	330	300	300	240	180
C_{TUNE}	1000pF	1200pF	2200pF	3300pF	8200pF

General recommended values of R_{TUNE} and C_{TUNE} for $V_{in}=12V$ and various external ceramic capacitor combinations.

Table 3. Recommended values of R_{TUNE} and C_{TUNE} to obtain transient deviation of $\leq 2\%$ of V_{out} for a 3A step load with $V_{in}=12V$.

V_o	5V	3.3V	2.5V	1.8V	1.2V	0.6V
Co	3x47µF Ceramic	3x47µF Ceramic	4x47µF Ceramic	1x47µF + 1x330µF Polymer	1x47µF + 1x330µF Polymer	2x47µF + 3x330µF Polymer
R_{TUNE}	300	300	300	300	300	200
C_{TUNE}	1000pF	1200pF	1800pF	2700pF	399pF	15nF
ΔV	60mV	54mV	42mV	26mV	22mV	11mV

Recommended values of R_{TUNE} and C_{TUNE} to obtain transient deviation of 2% of V_{out} for a 3A step load with $V_{in}=12V$

Note: The capacitors used in the Tunable Loop tables are 47 µF/3 mΩ ESR ceramic and 330 µF/12 mΩ ESR polymer capacitors

38. PMBUS INTERFACE CAPABILITY

The SLDM-06D1Ax power modules have a PMBus interface that supports both communication and control. The PMBus Power Management Protocol Specification can be obtained from www.pmbus.org. The modules support a subset of version 1.1 of the specification (see Table 6 for a list of the specific commands supported). Most module parameters can be programmed using PMBus and stored as defaults for later use.

All communication over the module PMBus interface must support the Packet Error Checking (PEC) scheme. The PMBus master must generate the correct PEC byte for all transactions, and check the PEC byte returned by the module.

The module also supports the SMBALERT# response protocol whereby the module can alert the bus master if it wants to talk. For more information on the SMBus alert response protocol, see the System Management Bus (SMBus) specification.

The module has non-volatile memory that is used to store configuration settings. Not all settings programmed into the device are automatically saved into this non-volatile memory, only those specifically identified as capable of being stored can be saved (see Table 6 for which command parameters can be saved to non-volatile storage).

39. PMBUS DATA FORMAT

For commands that set thresholds, voltages or report such quantities, the module supports the “Linear” data format among the three data formats supported by PMBus. The Linear Data Format is a two byte value with an 11-bit, two’s complement mantissa and a 5-bit, two’s complement exponent. The format of the two data bytes is shown below:

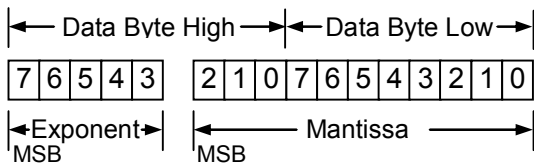

*The value is of the number is then given by
 Value = Mantissa x 2^{Exponent}*



Asia-Pacific
 +86 755 298 85888

Europe, Middle East
 +353 61 225 977

North America
 +1 408 785 5200

40. PMBUS ADDRESSING

The power module can be addressed through the PMBus using a device address. The module has 64 possible addresses (0 to 63 in decimal) which can be set using resistors connected from the ADDR0 and ADDR1 pins to SIG_GND. Note that some of these addresses (0, 1, 2, 3, 4, 5, 6, 7, 8, 9, 10, 11, 12, 40, 44, 45, 55 in decimal) are reserved according to the SMBus specifications and may not be useable. The address is set in the form of two octal (0 to 7) digits, with each pin setting one digit. The ADDR1 pin sets the high order digit and ADDR0 sets the low order digit. The resistor values suggested for each digit are shown in Table 4 (1% tolerance resistors are recommended).

Note that if either address resistor value is outside the range specified in Table 4, the module will respond to address 127.

Table 4

Digit	Resistor Value (K Ω)
0	10
1	15.4
2	23.7
3	36.5
4	54.9
5	84.5
6	130
7	200

The user must know which I²C addresses are reserved in a system for special functions and set the address of the module to avoid interfering with other system operations. Both 100kHz and 400kHz bus speeds are supported by the module. Connection for the PMBus interface should follow the High Power DC specifications given in section 3.1.3 in the SMBus specification V2.0 for the 400kHz bus speed or the Low Power DC specifications in section 3.1.2. The complete SMBus specification is available from the SMBus web site, smbus.org.

Figure 48

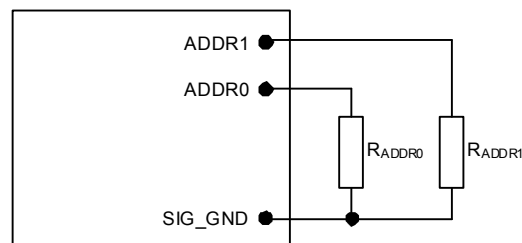

Circuit showing connection of resistors used to set the PMBus address of the module.

41. PMBUS ENABLE ON/OFF

The module can also be turned on and off via the PMBus interface. The OPERATION command is used to actually turn the module on and off via the PMBus, while the ON_OFF_CONFIG command configures the combination of analog ON/OFF pin input and PMBus commands needed to turn the module on and off. Bit [7] in the OPERATION command data byte enables the module, with the following functions:

- 0 : Output is disabled
- 1 : Output is enabled

This module uses the lower five bits of the ON_OFF_CONFIG data byte to set various ON/OFF options as follows:

Bit Position	4	3	2	1	0
Access	r/w	r/w	r/w	r/w	r
Function	PU	CMD	CPR	POL	CPA
Default Value	1	0	1	1	1

PU: Sets the default to either operate any time input power is present or for the ON/OFF to be controlled by the analog ON/OFF input and the PMBus OPERATION command. This bit is used together with the CP, CMD and ON bits to determine startup.

Bit Value	Action
0	Module powers up any time power is present regardless of state of the analog ON/OFF pin
1	Module does not power up until commanded by the analog ON/OFF pin and the OPERATION command as programmed in bits [2:0] of the ON_OFF_CONFIG register.

CMD: The CMD bit controls how the device responds to the OPERATION command.

Bit Value	Action
0	Module ignores the ON bit in the OPERATION command
1	Module responds to the ON bit in the OPERATION command

CPR: Sets the response of the analog ON/OFF pin. This bit is used together with the CMD, PU and ON bits to determine startup.

Bit Value	Action
0	Module ignores the analog ON/OFF pin, i.e. ON/OFF is only controlled through the PMBUS via the OPERATION command
1	Module requires the analog ON/OFF pin to be asserted to start the unit



Asia-Pacific
+86 755 298 85888

Europe, Middle East
+353 61 225 977

North America
+1 408 785 5200