



Chipsmall Limited consists of a professional team with an average of over 10 year of expertise in the distribution of electronic components. Based in Hongkong, we have already established firm and mutual-benefit business relationships with customers from,Europe,America and south Asia,supplying obsolete and hard-to-find components to meet their specific needs.

With the principle of “Quality Parts,Customers Priority,Honest Operation,and Considerate Service”,our business mainly focus on the distribution of electronic components. Line cards we deal with include Microchip,ALPS,ROHM,Xilinx,Pulse,ON,Everlight and Freescale. Main products comprise IC,Modules,Potentiometer,IC Socket,Relay,Connector.Our parts cover such applications as commercial,industrial, and automotives areas.

We are looking forward to setting up business relationship with you and hope to provide you with the best service and solution. Let us make a better world for our industry!



Contact us

Tel: +86-755-8981 8866 Fax: +86-755-8427 6832

Email & Skype: info@chipsmall.com Web: www.chipsmall.com

Address: A1208, Overseas Decoration Building, #122 Zhenhua RD., Futian, Shenzhen, China



SLQ-HC60

Milliliter Flow Meter for Hydrocarbons

- Maximum flows up to 80 ml/min
- Sensitive to lowest flows
- Straight flow path, no moving parts
- Fast response time: < 50 ms
- Optimized for hydrocarbons



1 Introduction SLQ-HC60

The SLQ-HC60 Liquid Flow Meter enables fast, non invasive measurements of liquid flow up to 80 ml/min. This product line is especially suited for process monitoring applications in automation technology which require high sensitivity in the milliliter range. It is suited for use with almost all hydrocarbons, as for example, alcohols, oils, gasoline, diesel, etc. and many other chemicals. Excellent chemical resistance is ensured: The flow path of the SLQ-HC60 Liquid Flow Meters is formed by a simple, straight glass capillary. This Swiss made, non invasive flow meter is based on Sensirion’s patented CMOSens® Technology (US Patent 6,813,944 B2). An internal fourth generation MEMS sensor chip combines a thermal high precision sensor element with amplification circuits and digital intelligence for linearization and temperature compensation on one single microchip – the product’s core element.

2 Sensing Performance

In Table 1 the flow sensor’s performance for use with Isopropyl Alcohol (IPA) is given. For other hydrocarbons the values will be slightly different as the performance depends on the medium used. Due to the optimized output signal the repeatability is nearly constant over a wide flow range. The repeatability depends on the integration time^a of the analog signal acquisition. Longer integration time leads to better repeatability of the flow measurement (see table 1). The temperature compensation is optimized for use with IPA and shows very good performance for most hydrocarbons and other media.

Table 1: Model specific performance of SLQ-HC60 for IPA (all data at 20°C, 1 bar_{abs} unless otherwise noted)

Parameter	Condition	SLQ-HC60	Units
Maximum Flow Rate	Best Performance	80	ml/min
	Reduced Performance	100	
Repeatability ^b (whichever is greater)	0.2 sec integration time	1.5	% m.v.
		0.2	% F.S.
	2 sec integration time	1	% m.v.
		0.07	% F.S.
Flow Detection Response Time		< 50	ms
Accuracy ^c		10	% m.v.
Response Time On Power-Up		120	ms
Mounting Orientation Sensitivity ^d	For IPA	0.25	ml/min
Operating Temperature	Temperature Compensated	+10...+40	°C
	Functional	+0 ... +55	°C
Ambient storage Temperature	(empty flow channel)	-10...+60	°C

^a This refers to the time over which the analog acquisition device averages the input signal. Refer to the datasheet of your device.

^b For medium IPA using 1 σ standard deviation of consecutive flow measurements.

^c With IPA, 2.5-80 ml/min, after conversion of the Vout signal via the exponential relation. See section 3.1

^d Normal position: Horizontal Flow channel, connector horizontally.

3 Output Signal and Media Compatibility

3.1 Output Signal

The SLQ-HC60 flow meter comes with an analog output (0...10V). Depending on the media used, the output will be about 5 Volt at zero flow. For positive flow rates the output signal increases logarithmically^a with the flow rate for IPA (see figure 1). This signal characteristic has the advantage that the flow meter can be used at various flow rates with a constant relative error and makes measurements for a wide spectrum of liquids possible.

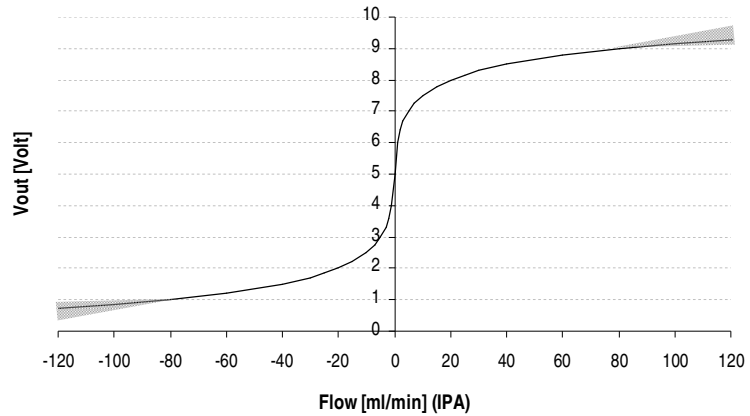

Figure 1: Sensor Signal for IPA

3.2 Signal for Other Media

For other media but IPA the form of the sensor signal will differ slightly as is demonstrated in figure 2. When using the sensor with other media but IPA, ask Sensirion for advice on how to handle the sensor signal to suit your requirements.

Because of the drastically different sensor response the sensor is not suited for use with water or aqueous solutions.

3.3 Maximum Flow Rate for Common Media

Due to the measurement principle, the thermal properties of the medium determine the sensor characteristics and the dynamic range of the device. For most hydrocarbons and most other media this range extends to about 80 ml/min. With reduced performance even rates of 100 ml/min or higher can be reached for some media. For low viscosity (< 1 centipoise) media the dynamic range can be limited by turbulence.

The dynamic ranges for various media are given in Table 2. For other media similar values can be expected.

Attention: If unsure about your medium please contact Sensirion for assistance.

Conversion: Signal to Flow (for positive flow rates) ^a
$\text{Flow [ml/min]} = (\text{Exp}[(\text{Vout}-5)/0.729]-1)/3$ $= 1/3 * (e^{(\text{Vout}-5)/0.729}-1)$

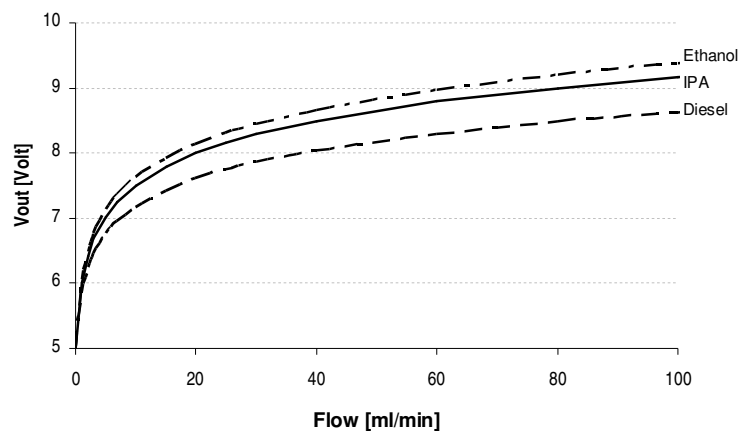

Figure 2: Sensor Signal for Various Media

Table 2: Examples for common media

Medium	Maximum Flow Rate	Units
IPA	80 (100 ^b)	ml/min
Ethanol, Methanol, Gasoline	~50	
Acetone	~ 40	
Diesel, Petroleum, Veg. Oils	80 (100 ^b)	
Silicon Oil, Ether	< 100	

^a The flow rate for IPA is given by $\text{Flow[ml/min]} = (\text{Exp}[(\text{Vout}-5)/0.729]-1)/3$ for positive flow rates, i.e. above 5V. For negative flow rates the signal is symmetric: $\text{Flow[ml/min]} = - (\text{Exp}[(5-\text{Vout})/0.729]-1)/3$. In Excel or when programming one can use the following formula for the full flow range: $\text{Flow[ml/min]} = \text{SIGN}(\text{Vout} - 5) * (\text{EXP}[\text{SIGN}(\text{Vout} - 5) * (\text{Vout} - 5) / 0.729] - 1) / 3$ where SIGN is -1 if the argument is negative and +1 if the argument is positive.

^b At reduced requirements on accuracy (repeatability for other media but IPA) and exchangeability of sensors.

3.4 Exchangeability

Every SLQ-HC60 is calibrated for IPA. This makes the sensors also exchangeable for use with other media, meaning that once the sensors are characterized for a particular medium the same values can be used for further sensors. Depending on the media, variations between sensors of 6– 20% are typical.

4 Cleaning

Due to the measurement principle the sensor is sensitive to deposits on the inside of the sensor's capillary. Especially when changing from one liquid to another sufficient cleaning steps have to be performed to avoid non-soluble remainders on the capillary wall. Inadequate cleaning can lead to an offset and low repeatability. The cleaning procedure has to efficiently remove contaminations from the borosilicate glass surfaces. This is the material which is used for the straight flow channel inside the flow meter.

Any form of mechanical cleaning has to be avoided. This will easily damage the internal capillary.

5 Electrical and Mechanical Specifications

5.1 Electrical Specifications

Table 2: DC Characteristics.

Parameter	Conditions	Min.	Typ.	Max.	Units
Power Supply DC, VDD		16	24	26	V
Operating Current	V _{DD} = 24 V ----, no load		3	4	mA
Analog Out Voltage Range		0		10	V
Load at Analog Out		10		∞	kΩ
Capacitive Load at Analog out				Tbd	pF

5.2 Electrical Connector and Pinout

Connector Type: Lumberg Pico (M8) male, 8-pole, threaded lock.

Pin	Function	Connect to	Color (pigtail cable)
1	Power Supply 24V	(+) of Power Supply	white
2		Do not use. ^a	brown
3			green
4			yellow
5			grey
6	Analog Out 0-10 V	(+) of Signal Acquisition	pink
7	GND	Connect to ground/(-) of Power Supply and Signal Acquisition	blue
8	GND		red

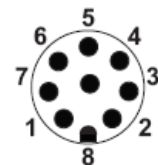

Note: Pins 7 and 8 have to be connected to ground of the Power Supply and the Signal Acquisition. Pins 2-5 are used in the calibration procedure, they have no functionality in normal use. Pins 2-5 cannot be used "as" the ground; they are not connected with Pins 7 and 8 inside the sensor.

5.3 Fluidic Connections

The repeatability of the measurement depends on a laminar flow of the liquid. Especially with low viscosity media improper connections to the sensor can unnecessarily reduce the maximum flow rate. Tubing with an inner diameter of less than 1.8 mm should be avoided. Make sure that the tubing has been cut properly.

^a Or connect to common ground with Pin 7 and 8. Never connect to (+) of Power Supply!

5.4 Mechanical Specifications and Pressure Rating

Table 3: Mechanical Specifications and Pressure Rating

Parameter	SLQ-HC60
Fluid Connector Standard (Fittings)	¼-28 flat bottom port for 1/8", 3mm OD tubing
Wetted Materials:	
• Internal Sensor Capillary Material	Duran® (borosilicate glass 3.3)
• Fitting Material	100% PEEK™ (polyetheretherketone)
• Additional Sealing Material	Tefzel® (ETFE)
Overpressure Resistance	3 bar 45 psi
Maximum Pressure Drop (at 80 ml/min flow rate for IPA)	40 mbar
Internal Sensor Capillary, Inner Diameter	1.8 mm
Protection Class	IP 65
Total Mass	53 g

Attention	
<p>Mechanical shocks and connecting to the fittings with excessive force can lead to stress on the internal thin walled glass capillary and can cause it to break. Test for leakage after every time new connections are made. Refer to Handling Instructions for precise information.</p>	<p>!</p>

6 Physical Dimensions

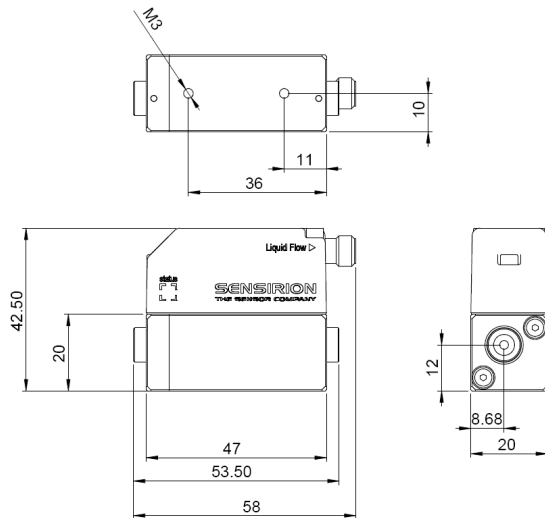

7 Ordering Info

The SLQ-HC60 can be ordered in the Flow Meter Kit at quantities up to 3 units. The Flow Meter Kit contains the sensor, the suitable connecting cable, a set of compression fittings for 1/8" OD tubing and a set of various barb connectors for easy setup for testing.

When ordering the SLQ-HC60 alone without the Flow Meter Kit it comes only with the cables but without fitting material.

Product	Article Number
Flow Meter Kit SLQ-HC60	1-100870-01
SLQ-HC60	1-100605-01

8 Important Notices

8.1 Warning, personal injury

Do not use this product as safety or emergency stop devices or in any other application where failure of the product could result in personal injury. Do not use this product for applications other than its intended and authorized use. Before installing, handling, using or servicing this product, please consult the data sheet and application notes. Failure to comply with these instructions could result in death or serious injury.

If the Buyer shall purchase or use SENSIRION products for any unintended or unauthorized application, Buyer shall defend, indemnify and hold harmless SENSIRION and its officers, employees, subsidiaries, affiliates and distributors against all claims, costs, damages and expenses, and reasonable attorney fees arising out of, directly or indirectly, any claim of personal injury or death associated with such unintended or unauthorized use, even if SENSIRION shall be allegedly negligent with respect to the design or the manufacture of the product.

8.2 ESD Precautions

The inherent design of this component causes it to be sensitive to electrostatic discharge (ESD). To prevent ESD-induced damage and/or degradation, take customary and statutory ESD precautions when handling this product.

See application note "ESD, Latchup and EMC" for more information.

8.3 Warranty

SENSIRION warrants solely to the original purchaser of this product for a period of 12 months (one year) from the date of delivery that this product shall be of the quality, material and workmanship defined in SENSIRION's published specifications of the product. Within such period, if proven to be defective, SENSIRION shall repair and/or replace this product, in SENSIRION's discretion, free of charge to the Buyer, provided that:

- notice in writing describing the defects shall be given to SENSIRION within fourteen (14) days after their appearance;
- such defects shall be found, to SENSIRION's reasonable satisfaction, to have arisen from SENSIRION's faulty design, material, or workmanship;
- the defective product shall be returned to SENSIRION's factory at the Buyer's expense; and
- the warranty period for any repaired or replaced product shall be limited to the unexpired portion of the original period.

This warranty does not apply to any equipment which has not been installed and used within the specifications recommended by SENSIRION for the intended and proper use of the equipment. EXCEPT FOR THE WARRANTIES EXPRESSLY SET FORTH HEREIN, SENSIRION MAKES NO WARRANTIES, EITHER EXPRESS OR IMPLIED, WITH RESPECT TO THE PRODUCT. ANY AND ALL WARRANTIES, INCLUDING WITHOUT LIMITATION, WARRANTIES OF MERCHANTABILITY OR FITNESS FOR A PARTICULAR PURPOSE, ARE EXPRESSLY EXCLUDED AND DECLINED.

SENSIRION is only liable for defects of this product arising under the conditions of operation provided for in the data sheet and proper use of the goods. SENSIRION explicitly disclaims all warranties, express or implied, for any period during which the goods are operated or stored not in accordance with the technical specifications.

SENSIRION does not assume any liability arising out of any application or use of any product or circuit and specifically disclaims any and all liability, including without limitation consequential or incidental damages. All operating parameters, including without limitation recommended parameters, must be validated for each customer's applications by

customer's technical experts. Recommended parameters can and do vary in different applications.

SENSIRION reserves the right, without further notice, (i) to change the product specifications and/or the information in this document and (ii) to improve reliability, functions and design of this product.

Copyright© 2001-2007, SENSIRION.

CMOSens® is a trademark of Sensirion

All rights reserved.

Trademarks where mentioned. E.g.

PEEK™ is a trademark of Victrex PLC

Tefzel® is a registered trademark of DuPont Corporation

Duran® is a trademark of the SCHOTT-Group

FCC and CE Statement

This product has been tested and found to comply with the limits for a Class B digital device, pursuant to part 15 of the FCC Rules (FCC CFR 47). These limits are designed to provide reasonable protection against harmful interference in a residential installation. This equipment generates, uses and can radiate radio frequency energy and, if not installed and used in accordance with the instructions, may cause harmful interference to radio communications. However, there is no guarantee that interference will not occur in a particular installation. If this equipment does cause harmful interference to radio or television reception, which can be determined by turning the equipment off and on, the user is encouraged to try to correct the interference by one of more of the following measures:

- Reorient or relocate the receiving antenna.
- Increase the separation between the equipment and the receiver
- Connect the equipment into an outlet on a circuit different from that to which the receiver is connected.
- Consult a dealer or an experienced radio/TV technician for help.



The devices fully comply with norm EN 50081-2 (Emission Test Series) as well as EN 50082-2 (Immunity Test Series). ESD protection up to 2kVolt.

8.4 RoHS and WEEE Statement

The SLQ product family complies with requirements of the following directives:

- EU Directive 2002/96/EC on waste electrical and electronic equipment (WEEE), OJ13.02.2003; esp. its Article 6 (1) with Annex II.
- EU Directive 2002/95/EC on the restriction of the use of certain hazardous substances in electrical and electronic equipment (RoHS), OJ 13.02.2003; esp. its Article 4.



Headquarter and Sales Office

SENSIRION AG
Laubisruestr. 50
CH-8712 Staefa ZH
Switzerland

Phone: +41 44 306 40 00
Fax: +41 44 306 40 30
info@sensirion.com
<http://www.sensirion.com>

SENSIRION Korea Co. Ltd.
#1414, Anyang Construction Tower B/D,
1112-1, Bisan-dong, Anyang-city,
Gyeonggi-Province, South Korea

Phone: +82-31-440-9925~27
Fax: +82-31-440-9927
info@sensirion.co.kr
<http://www.sensirion.co.kr>

SENSIRION Inc.
Westlake Pl. Ctr. I, suite 204
2801 Townsgate Road
Westlake Village, CA 91361
USA

Phone: +1 805 409 4900
Fax: +1 805 435 0467
michael.karst@sensirion.com
<http://www.sensirion.com>

SENSIRION China Co. Ltd.
Room 2411, Main Tower
Jin Zhong Huan Business Building,
Futian District, Shenzhen, PR China
Postal Code 518048

Phone: +86 755 8252 1501
Fax: +86 755 8252 1580
info@sensirion.com.cn
<http://www.sensirion.com.cn>

SENSIRION Japan
Sensirion Japan Co. Ltd.
Shinagawa Station Bldg. 7F
4-23-5 Takanawa
Minato-ku, Tokyo, Japan

Phone: +81 3-3444-4940
Fax: +81 3-3444-4939
info@sensirion.co.jp
<http://www.sensirion.co.jp>

Find your local representative at: <http://www.sensirion.com/reps>