



Chipsmall Limited consists of a professional team with an average of over 10 year of expertise in the distribution of electronic components. Based in Hongkong, we have already established firm and mutual-benefit business relationships with customers from,Europe,America and south Asia,supplying obsolete and hard-to-find components to meet their specific needs.

With the principle of “Quality Parts,Customers Priority,Honest Operation,and Considerate Service”,our business mainly focus on the distribution of electronic components. Line cards we deal with include Microchip,ALPS,ROHM,Xilinx,Pulse,ON,Everlight and Freescale. Main products comprise IC,Modules,Potentiometer,IC Socket,Relay,Connector.Our parts cover such applications as commercial,industrial, and automotives areas.

We are looking forward to setting up business relationship with you and hope to provide you with the best service and solution. Let us make a better world for our industry!



Contact us

Tel: +86-755-8981 8866 Fax: +86-755-8427 6832

Email & Skype: info@chipsmall.com Web: www.chipsmall.com

Address: A1208, Overseas Decoration Building, #122 Zhenhua RD., Futian, Shenzhen, China



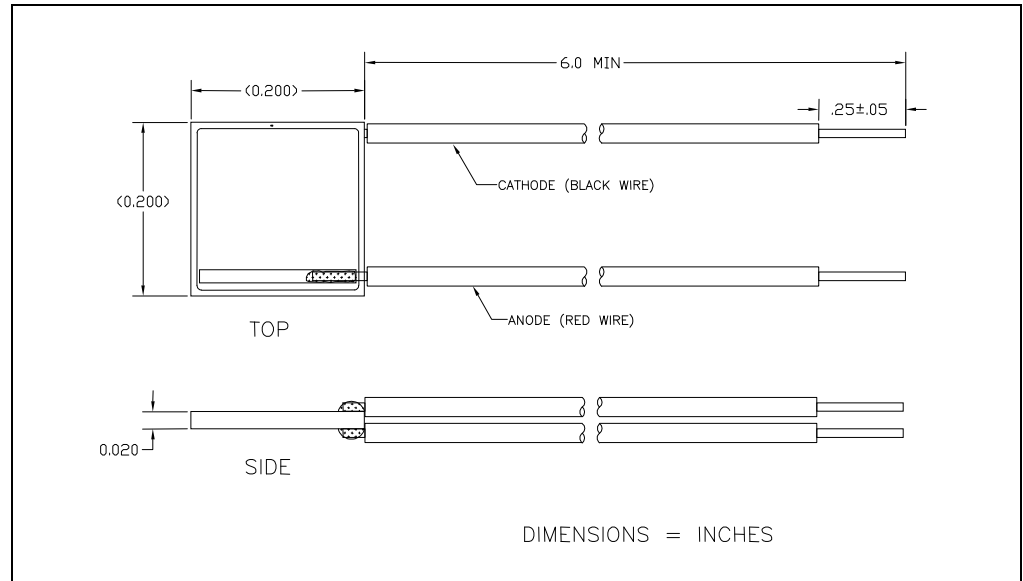

DESCRIPTION

The SLSD-71N200 is a solderable planar photodiode featuring low cost, high reliability, and linear short circuit current over a wide range of illumination. These devices are widely used for light sensing and power generation because of their stability and high efficiency. They are particularly suited to power conversion applications due to their low internal impedance, relatively high shunt impedance, and stability. The photodiodes have a protective coating that protects them from humidity effects. These devices also provide a reliable and inexpensive detector for instrumentation and light beam sensing applications.

RELIABILITY

This API high-reliability detector is in principle able to meet military test requirements (Mil-STD-750, Mil-STD-883) after proper screening and group test.

Contact API for recommendations on specific test conditions and procedures.

ABSOLUTE MAXIMUM RATINGS

Operating Temperature	-40	to	+105	°C	non condensing
Storage Temperature	-40	to	+105	°C	
Soldering Temperature			+240	°C	
Wavelength Range	400	to	1100	nm	

FEATURES

- Visible to IR spectral irradiance range
- High reliability
- Oxide passivation
- Linear short circuit current
- Low capacitance, high speed
- Si surface protected with the thin film coating

APPLICATIONS

- Light sensing
- Power generation



OPTO-ELECTRICAL PARAMETERS

T_a = 23 °C unless noted otherwise

PARAMETER	TEST CONDITIONS	MIN	TYP	MAX	UNITS
Short Circuit Current	V _R =0V, E _e =25mW/cm ² **	0.7	1.2	-	mA
Open Circuit Voltage	E _e =25mW/cm ² **	-	0.40	-	V
Dark Current	V _R =5V, E _e =0, T=25 °C	-	-	3.3	μA
Junction Capacitance	V _R =0V, E _e =0, f=1MHz	-	0.7	-	nF
Spectral Sensitivity	λ=940nm; Flood illumination*	-	0.55	-	A/W
Breakdown Voltage	I _R =100μA	20	-	-	V
Maximum Sensitivity Wavelength	-	-	930	-	nm
Acceptance Half Angle	(off center-line)	-	60	-	deg

* Minimum 50% of active area illuminated

** Light source @ 2854 °K

TYPICAL PERFORMANCE

DIRECTIONAL SENSITIVITY

