



Chipsmall Limited consists of a professional team with an average of over 10 year of expertise in the distribution of electronic components. Based in Hongkong, we have already established firm and mutual-benefit business relationships with customers from,Europe,America and south Asia,supplying obsolete and hard-to-find components to meet their specific needs.

With the principle of "Quality Parts,Customers Priority,Honest Operation,and Considerate Service",our business mainly focus on the distribution of electronic components. Line cards we deal with include Microchip,ALPS,ROHM,Xilinx,Pulse,ON,Everlight and Freescale. Main products comprise IC,Modules,Potentiometer,IC Socket,Relay,Connector.Our parts cover such applications as commercial,industrial, and automotives areas.

We are looking forward to setting up business relationship with you and hope to provide you with the best service and solution. Let us make a better world for our industry!



Contact us

Tel: +86-755-8981 8866 Fax: +86-755-8427 6832

Email & Skype: info@chipsmall.com Web: www.chipsmall.com

Address: A1208, Overseas Decoration Building, #122 Zhenhua RD., Futian, Shenzhen, China



SM1231 RF MODULE

USER GUIDE

Table of Contents

Table of Contents	2
Index of Figures	2
Index of Tables.....	2
1 Introduction	3
2 Reference Design	3
3 PCB Layout.....	6
4 BOM	7
5 References.....	7

Index of Figures

Figure 1: SM1211 Overview (Top View)	3
Figure 2: SM1231 Schematic Diagram	5
Figure 3: SM1231 PCB Layout (Top View).....	6

Index of Tables

Table 1: MCU Connector Pin Description	4
Table 2: SM1231 915 MHz BOM	7

1 Introduction

The purpose of this tool is to provide a development platform of the SX1231. User can build his application prototype by simply connecting the module to his target microcontroller and start developing his application software. The SM1231 module integrates the SX1231 reference design (chip + external components) plus miscellaneous useful connectors.

Note that this module is also used for the SX1231SKB Evaluation Kit.

It is recommended that this user guide be read in conjunction with the SX1231 datasheet.

2 Reference Design

As illustrated in Figure 1, below, the SM1231 reference design module consists of the following:

- Reference Design: This section includes the chip but also all the external components in an optimized BOM and form factor. When the user wishes to incorporate the SX1231 to PCB, it is strongly recommended that this reference design (i.e. schematics, placement, layout, BOM, etc...) is copied "as is" in the final application board to guarantee optimum performance, regulatory compliance and lowest development time and design effort.
- MCU Connector: Enables the user to connect the SX1231 control and interface pins to the host microcontroller (please refer to the SX1231 datasheet for further information).

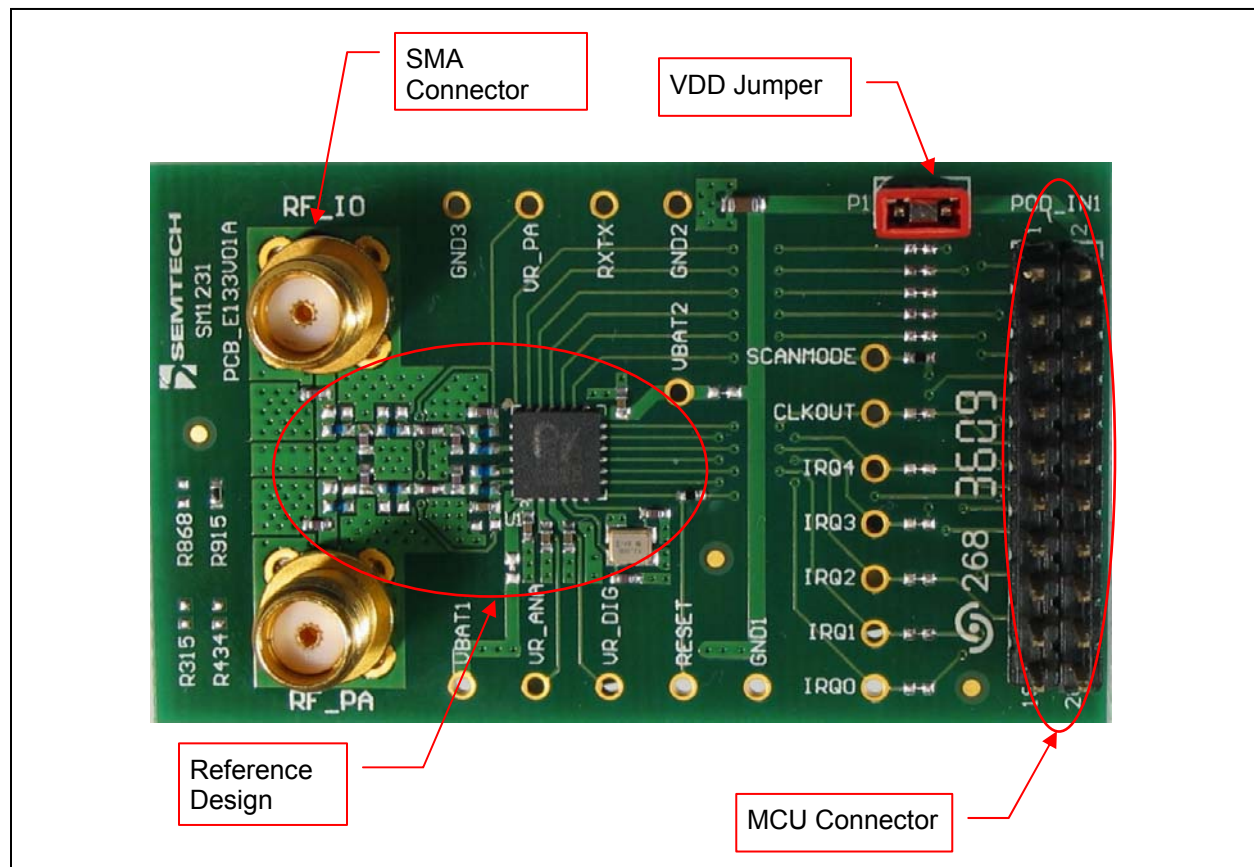

Figure 1: SM1231 Overview (Top View)

ADVANCED COMMUNICATIONS & SENSING

- SMA Connector: Provided for SMA Cable or antenna connection. Each board is delivered with a quarter-wave SMA antenna appropriate to the frequency band of operation. Note that the SM1231 module has two independent connectorized RF ports; RF_IO, the common LNA and low power transmitter PA port and RF_PA, the high power transmitter port.
- VDD jumper: Enables current consumption to be monitored and / or apply independent power supply to the module. When VDD jumper is made, power should be supplied via the MCU connector.

The pin-out of the MCU connector is tabulated below in Table 1.

<i>PIN #</i>	<i>NAME</i>	<i>TYPE</i>	<i>DESCRIPTION</i>
1	SCK	I	SPI Clock Input
2	VDD	I	Supply Voltage Connection
3	MOSI	I	SPI Data Input
4	GND	-	Ground Connection
5	DIO1/DCLK	I/O	Digital I/O, Software Configurable
6	DIO3	I/O	Digital I/O, Software Configurable
7	NSS	I	SPI Chip Select
8	MISO	O	SPI Data Output
9	DIO5	I/O	Digital I/O, Software Configurable
10	RESET	I/O	Reset Trigger Input / POR Flag
11	DIO4	I/O	Digital I/O, Software Configurable
12	DIO0	-	Digital I/O, Software Configurable
13	RXTX	O	RX/TX Switch Control; High in TX
14	-	-	Not Connected
15	DIO1/DCLK	I/O	Digital I/O, Software Configurable
16	-	-	Not Connected
17	DIO2/DATA	I/O	Digital I/O, Software Configurable
18	-	-	Not Connected
19	-	-	Not Connected
20	-	-	Not Connected

Table 1: MCU Connector Pin Description

The SM1231 reference design is available for download from the Semtech website, and contains the latest schematic, PCB Gerber files and BOMs for 315 MHz, 434 MHz, 868 MHz and 915 MHz frequency bands of operation.

The SM1231 Schematic diagram is illustrated in Figure 2.

Software drivers are available for the SX1231 and can be found in technical note TN8000.18 and source code ("XE8000 Driving XE1200 Transceivers Standard API Definitions") available for download from the Semtech website.

ADVANCED COMMUNICATIONS & SENSING

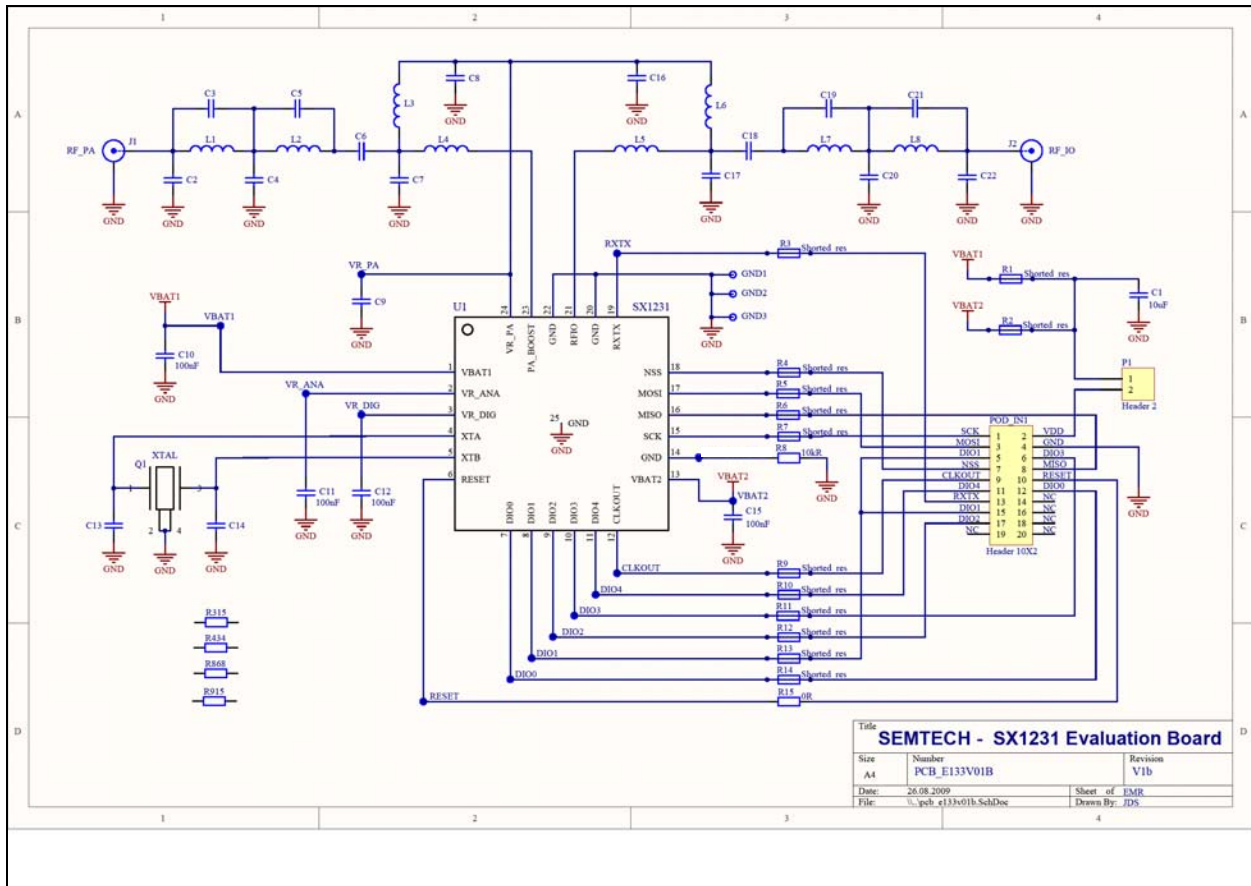

Figure 2: SM1231 Schematic Diagram

3 PCB Layout

As illustrated below in Figure 3, the SM1231 reference design PCB layout has the following characteristics:

- Compact active area reference design () which can easily be accommodated in a very small PCB
- Standard PCB technology (2 layers, 1.6 mm / 63 mils FR4 dielectric)

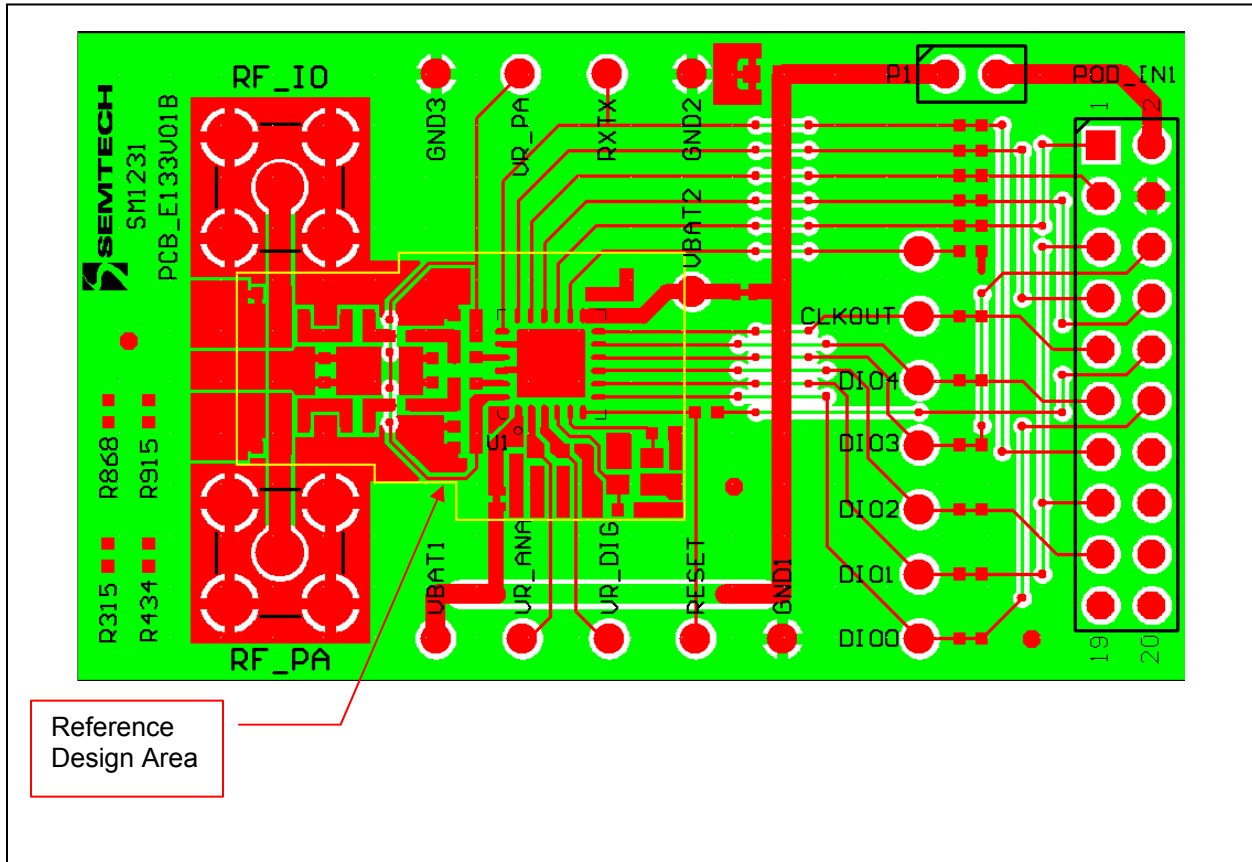

Figure 3: SM1231 PCB Layout (Top View)

4 BOM

An example BOM for the 915 MHz variant of the SM1231 is tabulated in Table 2.

REF	VALUE	TOL (\pm)	SIZE	COMMENT
U1	SX1231	-	VQFN24	SX1231 Low-Power UHF Integrated Transceiver
R15	0R	1%	0402	External RESET pin
C1	10 μ F	20%	0603	Decoupling
C2	3.3pF	0.25pF	0402	PA_BOOST Matching (Comp. Value is Band Specific)
C3	N/F	-	0402	PA_BOOST Matching (Comp. Value is Band Specific)
C4	6.8pF	0.5pF	0402	PA_BOOST Matching (Comp. Value is Band Specific)
C5	N/F	-	0402	PA_BOOST Matching (Comp. Value is Band Specific)
C6	22pF	5%	0402	PA_BOOST Matching (Comp. Value is Band Specific)
C7	8.2pF	0.5pF	0402	PA_BOOST Matching (Comp. Value is Band Specific)
C8	10nF	10%	0402	Decoupling
C10	100nF	10%	0402	Decoupling
C11	100nF	10%	0402	Decoupling
C12	100nF	5%	0402	Decoupling
C13	15pF	5%	0402	Crystal Load Capacitor
C14	15pF	5%	0402	Crystal Load Capacitor
C15	100nF	10%	0402	Decoupling
C16	68pF	5%	0402	Decoupling
C17	4.7pF	0.25pF	0402	RFIO Matching (Comp. Value is Band Specific)
C18	8.2pF	5%	0402	RFIO Matching (Comp. Value is Band Specific)
C19	N/F	-	0402	RFIO Matching (Comp. Value is Band Specific)
C20	6.8pF	0.5pF	0402	RFIO Matching (Comp. Value is Band Specific)
C21	N/F	-	0402	RFIO Matching (Comp. Value is Band Specific)
C22	5.6pF	0.5pF	0402	RFIO Matching (Comp. Value is Band Specific)
L1	5.6nH	0.2nH	0402	PA_BOOST Matching (Comp. Value is Band Specific)
L2	5.6nH	0.2nH	0402	PA_BOOST Matching (Comp. Value is Band Specific)
L3	22nH	5%	0402	PA_BOOST Matching (Comp. Value is Band Specific)
L4	2.7nH	0.5nH	0402	PA_BOOST Matching (Comp. Value is Band Specific)
L5	3.9nH	0.2nH	0402	RFIO Matching (Comp. Value is Band Specific)
L6	33nH	5%	0402	RFIO Matching (Comp. Value is Band Specific)
L7	6.8nH	5%	0402	RFIO Matching (Comp. Value is Band Specific)
L8	6.8nH	5%	0402	RFIO Matching (Comp. Value is Band Specific)
Q1	32.000MHz	-	NX2520SA	NDK Surface mount type crystal \pm 10ppm, CLoad=10pF

Table 2: SM1231 915 MHz BOM

5 References

- SX1231 Datasheet
- TN8000.18 Technical Note "XE8000 driving XE1200 transceivers Standard API definitions"

© Semtech 2009

All rights reserved. Reproduction in whole or in part is prohibited without the prior written consent of the copyright owner. The information presented in this document does not form part of any quotation or contract, is believed to be accurate and reliable and may be changed without notice. No liability will be accepted by the publisher for any consequence of its use. Publication thereof does not convey nor imply any license under patent or other industrial or intellectual property rights. Semtech assumes no responsibility or liability whatsoever for any failure or unexpected operation resulting from misuse, neglect improper installation, repair or improper handling or unusual physical or electrical stress including, but not limited to, exposure to parameters beyond the specified maximum ratings or operation outside the specified range.

SEMTECH PRODUCTS ARE NOT DESIGNED, INTENDED, AUTHORIZED OR WARRANTED TO BE SUITABLE FOR USE IN LIFE-SUPPORT APPLICATIONS, DEVICES OR SYSTEMS OR OTHER CRITICAL APPLICATIONS. INCLUSION OF SEMTECH PRODUCTS IN SUCH APPLICATIONS IS UNDERSTOOD TO BE UNDERTAKEN SOLELY AT THE CUSTOMER'S OWN RISK.

Should a customer purchase or use Semtech products for any such unauthorized application, the customer shall indemnify and hold Semtech and its officers, employees, subsidiaries, affiliates, and distributors harmless against all claims, costs damages and attorney fees which could arise.

Contact information

Semtech Corporation
Advanced Communication and Sensing Products Division
200 Flynn Road, Camarillo, CA 93012
Phone: (805) 498-2111 Fax: (805) 498-3804
E-mail: sales@semtech.com
Support_RF@semtech.com
Internet: <http://www.semtech.com>