



Chipsmall Limited consists of a professional team with an average of over 10 year of expertise in the distribution of electronic components. Based in Hongkong, we have already established firm and mutual-benefit business relationships with customers from,Europe,America and south Asia,supplying obsolete and hard-to-find components to meet their specific needs.

With the principle of “Quality Parts,Customers Priority,Honest Operation,and Considerate Service”,our business mainly focus on the distribution of electronic components. Line cards we deal with include Microchip,ALPS,ROHM,Xilinx,Pulse,ON,Everlight and Freescale. Main products comprise IC,Modules,Potentiometer,IC Socket,Relay,Connector.Our parts cover such applications as commercial,industrial, and automotives areas.

We are looking forward to setting up business relationship with you and hope to provide you with the best service and solution. Let us make a better world for our industry!



Contact us

Tel: +86-755-8981 8866 Fax: +86-755-8427 6832

Email & Skype: info@chipsmall.com Web: www.chipsmall.com

Address: A1208, Overseas Decoration Building, #122 Zhenhua RD., Futian, Shenzhen, China



**N-PLC Transceiver
MultiStandard Narrowband
Power Line Communication Modem**

Communication technology by: 
Semitech Semiconductor

Product Overview

The SM2400 is the ultimate Narrowband Power Line Communication (N-PLC) modem that combines cost effective design optimized for PLC applications with a high level of programmability to address a multitude of communications schemes and evolving standards. Extremely flexible, the SM2400 system-on chip (SoC) features a dual core architecture for dedicated PHY signal processing and MAC layer functionality to guarantee superior communication performance while maintaining very high levels of flexibility and programmability for OFDM-based and other open standards and fully customized implementations. It contains a high-speed 256bit AES-CCM* engine to ensure standard compliance and secure communication, and all the necessary mixed signal components, such as A/D, D/A, OpAmp's, PGA to yield a cost effective PLC system design for any N- PLC application.

Features

- Dual core architecture with custom N-PLC optimized DSP and Data Link Layer 32bit controller
 - Supports a multitude of communication schemes via firmware loads
- High performing custom DSP engine with embedded turnkey firmware featuring:
 - Configurable operational band within 5-500KHz range – compliant with CENELEC, FCC and ARIB
 - OFDM and FSK/S-FSK modulations
 - Compliant with IEEE 1901.2, PRIME, G3-PLC 1.3.6 and 1.4, CTIA/EIA709.2
 - Proprietary extra-robust operation modes: XR, XXR
 - Selectable differential and coherent BPSK, QPSK, 8PSK and coherent 16QAM modulations
 - Configurable data rate up to 500kbps
 - Programmable frequency notching to improve coexistence
 - Jammer cancellation
 - Adaptive tone mapping (on-off sub-band bit loading)
 - FEC – Convolutional, Reed-Salomon and Viterbi coding
 - CRC16
 - Carrier RSSI, SNR and LQI indicators for best channel adaptation and L2/L3 metrics
 - Zero-crossing detector
- Programmable 32bit RISC protocol engine featuring:
 - Data Link Layer firmware options compliant with IEEE 1901.2, G3-PLC, PRIME, IEC61334-4-32 and others
 - IP adaptation layers – IPv4, 6LoWPAN
 - Carrier Sense Multiple Access/Collision Avoidance (CSMA/CA) channel access
 - Automatic Repeat Request (ARQ)
 - Meshing and self-discovery mechanisms
- CCM* with AES128 / AES256 encryption core
- On-chip Peripheral Interfaces:
 - SPI (slave) / UART host i/f
 - Up to 19 firmware controllable GPIO's
 - JTAG
 - SPI master for external flash
 - Up to 2 additional SPI slaves for metering, wireless transceiver or other devices

- Seamless interface to an external line driver for optimal system performance:
 - Integrated A/D and D/A
 - Integrated OpAmp's for RX and TX
 - Integrated PGA
- Low power operation modes
 - Offline mode
 - Listen mode
 - Receive mode
 - Transmit mode
- 3.3V (5V tolerant) digital I/O
- Receiver sensitivity of -80dBV
- -40 °C to +105 °C temperature range
- LQFP64 package

Benefits

- Single-chip modem with integrating Physical Layer (PHY) and Media Access Controller (MAC)
- Multitude of operation modes addressing all common OFDM-based standards including full compliance with: IEEE 1901.2, G3-PLC, PRIME
- Extremely robust proprietary modes of communication optimized for noisy power line environment
- High flexibility to address standard evolution, new standards and special proprietary modes
- Cost optimized system solution with integrated A/D, D/A, 2 OpAmp's, PGA
- Low power consumption

Applications

- Smart grid communication
- Advanced Metering Infrastructure (AMI)
- Automated Meter Reading (AMR)
- Street lighting control
- Solar and alternative energy management
- Smart home energy monitoring
- Building automation (BA)
- Supervisory Control And Data Acquisition (SCADA)

Figure 1. SM2400 N-PLC Transceiver



Description

The SM2400 is a highly programmable OFDM based N-PLC modem combining PHY, MAC with mixed signal components for optimal system cost and performance. The SM2400 combines the benefits of programmable architecture with power and cost efficiency by utilizing two 32bit cores configured specifically for N-PLC modulations and protocols.

The SM2400 comes with a set of firmware bundles implementing IEEE 1901.2 compliant PHY and MAC layers, a 6LoWPAN data link layer as well as PRIME, G3-PLC, FSK/BPSK, and other special modes tailored for smart metering and smart grid applications. The SM2400 is capable of achieving data rates of up to 500Kbps over 500KHz frequency band.

Proprietary and patented modes (XXR and XR modes) enable robust communication in harsh conditions for applications where standards compliance is not required.

The SM2400 enables secure communication featuring a 256-bit AES encryption core with CCM* mode support. Integrated analog front end featuring ADC, DAC, gain control and two OpAmp's allows for a very efficient system design with a low cost BOM.

The SM2400 executes its firmware from internal memory. The code is loaded at the boot time. The SM2400 can boot ether from an external SPI flash or from a host CPU, if such is present in the system, via UART or SPI, where the MCU is the master.

Typical Application Diagram

Figure 1-1. SM2400 Application Block Diagram

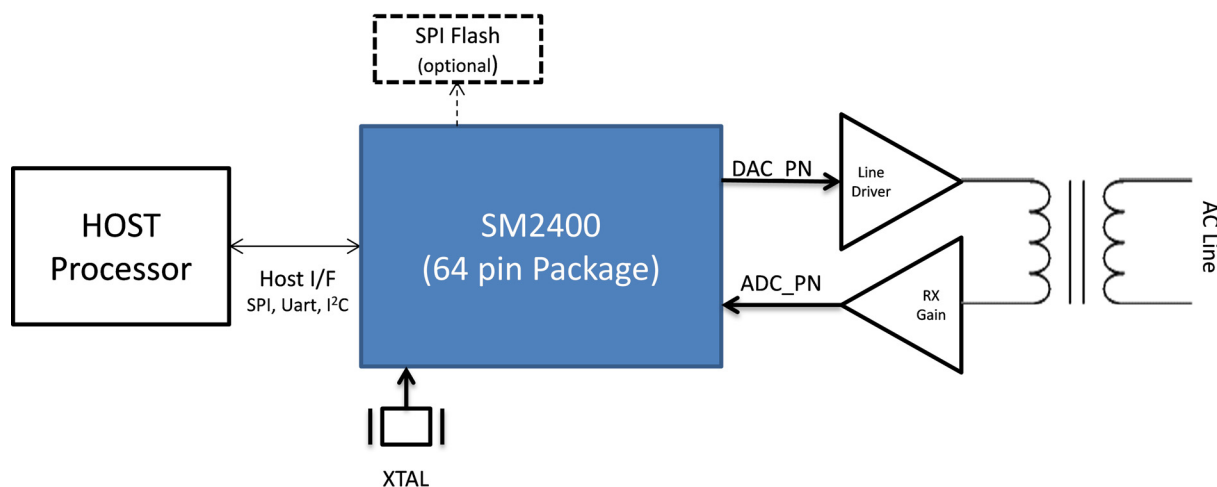

Block Diagram

Figure 1-2. SM2400 Block Diagram

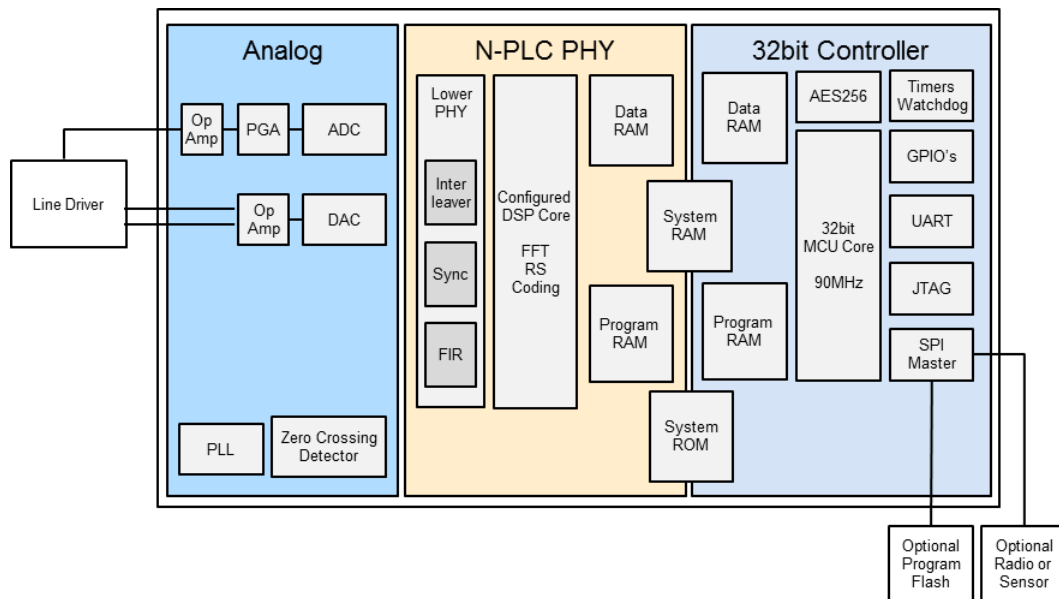

Modem

Selectable Modes and Modulations

The SM2400 can be configured to operate in one of several modes, such as: IEEE 1901.2, G3-PLC, PRIME, XR, XXR, etc. Different modes require different firmware images and imply different operational frequency bands with a varying number of carriers.

The SM2400 allows for configurable modulations per carrier. While most configurations are implied by the different standards, special modes can be created using specific combinations of carriers and modulations to achieve best performance in given channel conditions. The following modulations are available: Differential and coherent BPSK, QPSK and 8PSK and coherent 16QAM.

Forward Error Correction

The SM2400 supports Reed-Solomon (255,239) and (255,247), and rate half Convolutional coding with constraint length 7 (generator polynomial is [133,171]). In G3-PLC and IEEE 1901.2 modes Convolutional coding is concatenated with RS to achieve the best reliability. Special error correction modes include extra repetition coding for increased robustness and puncturing for increased data rate on capable channels.

Communication Medium Metrics

The SM2400 provides several metrics to assist L2 and L3 channel adaptation and routing. These metrics are: RSSI, SNR and LQI, which is a measure of the data rate. The RSSI is an estimate of received signal strength. Each packet received can be interrogated for its estimated signal strength. This is very useful in determining the signal to noise ratio of different nodes in the network. Even in low line noise conditions in a particular band the signal level might be attenuated significantly making data transmission unreliable. Network management systems can also interrogate each node for signal to noise ratios and create a database of all transmission path conditions. This produces a deterministic way of identifying the need for where repeaters in difficult and dynamically changing environments.

Security

AES encryption engine conforms to FIPS 197 standard featuring CCM*, ECB, CBC, CTR modes and of up to 256 bit key size.

Zero-crossing Detector

The SM2400 has a zero-crossing input pin which takes signals generated by an external zero-crossing detector based on the transition through zero volts of a 50Hz (or 60Hz) sinusoidal on the power line. The SM2400 provides a phase detection feature allowing the transmission beginning at an arbitrary phase offset and measuring the phase offset of the received packet.

Analog Front End (AFE)

The SM2400 integrates an AFE optimized for N-PLC communication, which includes ADC, DAC, PGA and 2 OpAmp's to achieve the best signal power with minimum external BOM. External components include coupling circuitry and high voltage line driver that can vary for different applications and for different operational bands.

Peripheral Interfaces

The SM2400 includes several peripheral interfaces for adding optional components. Those interfaces include UART, SPI master for external flash interface and JTAG. The second SPI extends to two additional devices that can be used for telemetry or to interface to a wireless transceiver.

Boot Options

The SM2400 can be configured to boot in one of four ways:

Table 1-1. Boot Options

Boot Mode	MODE[2:0]	Description
SPI Master	"000"	Read and process valid bootsector from SPI Master SSb0
CI SPI Slave	"001"	Wait on Command Interface via SPI Slave
CI UART	"010"	Wait on Command Interface via UART
Reserved	"1xx"	Reserved

Contact Information

For more information regarding the SM2400 including application notes, product samples, demonstration modules, pricing and ordering please contact:

Adesto Technologies
<http://www.adestotech.com>

Communication technology by:
Semitech Semiconductor





Corporate Office

California | USA

Adesto Headquarters

1250 Borregas Avenue

Sunnyvale, CA 94089

Phone: (+1) 408.400.0578

Email: contact@adestotech.com

© 2016 Adesto Technologies. All rights reserved. / Rev.: PB2400A–PWRLN–5/2016

Adesto® and the Adesto logo, are registered trademarks or trademarks of Adesto Technologies. All other marks are the property of their respective owners.

Disclaimer: Adesto Technologies Corporation makes no warranty for the use of its products, other than those expressly contained in the Company's standard warranty which is detailed in Adesto's Terms and Conditions located on the Company's web site. The Company assumes no responsibility for any errors which may appear in this document, reserves the right to change devices or specifications detailed herein at any time without notice, and does not make any commitment to update the information contained herein. No licenses to patents or other intellectual property of Adesto are granted by the Company in connection with the sale of Adesto products, expressly or by implication. Adesto's products are not authorized for use as critical components in life support devices or systems.