



Chipsmall Limited consists of a professional team with an average of over 10 year of expertise in the distribution of electronic components. Based in Hongkong, we have already established firm and mutual-benefit business relationships with customers from,Europe,America and south Asia,supplying obsolete and hard-to-find components to meet their specific needs.

With the principle of “Quality Parts,Customers Priority,Honest Operation,and Considerate Service”,our business mainly focus on the distribution of electronic components. Line cards we deal with include Microchip,ALPS,ROHM,Xilinx,Pulse,ON,Everlight and Freescale. Main products comprise IC,Modules,Potentiometer,IC Socket,Relay,Connector.Our parts cover such applications as commercial,industrial, and automotives areas.

We are looking forward to setting up business relationship with you and hope to provide you with the best service and solution. Let us make a better world for our industry!



## Contact us

Tel: +86-755-8981 8866 Fax: +86-755-8427 6832

Email & Skype: info@chipsmall.com Web: www.chipsmall.com

Address: A1208, Overseas Decoration Building, #122 Zhenhua RD., Futian, Shenzhen, China



## High temperature Transil™ for automotive applications

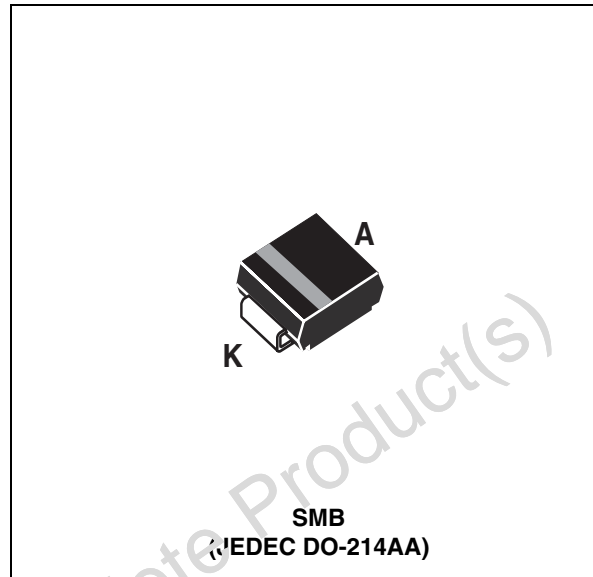
### Features

- High performance TRANSIL designed to fit high temperature environment like automotive applications
- High reliability planar technology
- High performance in voltage regulation mode
- Very low leakage current:
  - $I_R \text{ max.} = 5 \mu\text{A} @ T_{\text{amb}} = 150^\circ \text{C}$
- Peak pulse power: 600 W (10/1000  $\mu\text{s}$ )
- Fast response time
- Unidirectional type
- Low clamping factor

### Description

This high performance Transil series has been designed to fit high temperature environment such as automotive applications, using surface mount technology.

These devices are using high reliability planar technology resulting in high performances in voltage regulation mode and low leakage current at high temperature.



### Order codes

Part number	Marking
SM6HT24A	EMB
SM6HT27A	EPB
SM6HT30A	ERB
SM6HT36A	EVB
SM6HT39A	EXB
SM6HT43A	EYB

TM: TRANSIL is a trademark of STMicroelectronics

# 1 Characteristics

**Table 1. Absolute maximum rating ( $T_{amb} = 25^{\circ}C$ )**

Symbol	Parameter		Value	Unit
$P_{PP}$	Peak pulse power dissipation <sup>(1)</sup>	$T_j$ initial = $T_{amb}$	600	W
$P$	Power dissipation on infinite heatsink	$T_{amb} = 50^{\circ}C$	6	W
$I_{FSM}$	Non repetitive surge peak forward current for unidirectional types	$t_p = 10\text{ ms}$ $T_j$ initial = $T_{amb}$	75	A
$T_{stg} / T_j$	Storage and operating junction temperature range		-65 to 175	$^{\circ}C$
$T_L$	Maximum lead temperature for soldering during 10 s.		260	$^{\circ}C$

1. for a surge greater than the maximum values, the diode will fail in short circuit.

**Table 2. Thermal resistances**

Symbol	Parameter	Value	Unit
$R_{th(j-l)}$	Junction to leads	20	$^{\circ}C/W$
$R_{th(j-a)}$	Junction to ambient on printed circuit on recommended pad layout	100	$^{\circ}C/W$

**Table 3. Electrical characteristics ( $T_{amb} = 25^{\circ}C$ )**

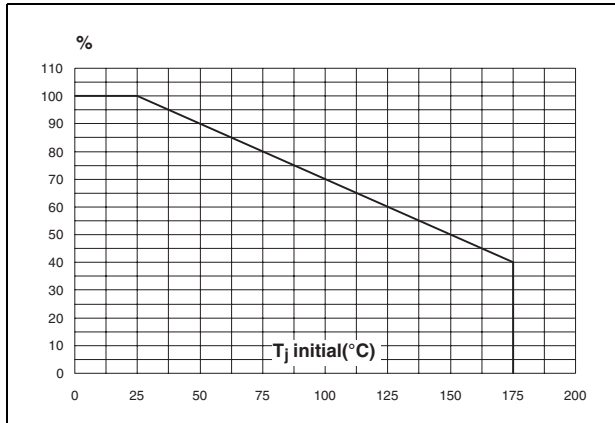
Symbol	Parameter
$V_{RM}$	Stand-off voltage
$V_{BR}$	Breakdown voltage
$V_{CL}$	Clamping voltage
$I_{RM}$	Leakage current
$I_{PP}$	Peak pulse current
$V_F$	Forward voltage drop $V_F < 3.5\text{ V} @ I_F = 50\text{ A}$ (pulse test: $t_p \leq 500\ \mu\text{s}$ )
$I_Z$	Continuous regulation current

Types	Marking	$I_{RM} @ V_{BR}$		$V_{BR} @ I_R$ <sup>(1)</sup>				$V_{CL} @ I_{PP}$		$\alpha T$ <sup>(2)</sup>	$I_Z @ T_{amb}=50^{\circ}C$	
		$T_{amb}=25^{\circ}C$	$T_{amb}=150^{\circ}C$				10/1000 $\mu\text{s}$					
		max	max	min	nom	max	max	max	max			
		$\mu\text{A}$	$\mu\text{A}$	V	V	V	V	mA	V	A	$10^{-4}/^{\circ}C$	mA
SM6HT24A	EMB	2	5	20.5	22.8	24	25.2	1	33.2	18.0	9.4	50
SM6HT27A	EPB			23.1	25.7	27	28.4		37.5	16.0	9.6	44
SM6HT30A	ERB			25.6	28.5	30	31.5		41.5	14.5	9.7	40
SM6HT36A	EVB			30.8	34.2	36	37.8		49.9	12.0	9.9	33
SM6HT39A	EXB			33.3	37.1	39	41.0		53.9	11.1	10.0	20
SM6HT43A	EYB			36.8	40.9	43	45.2		59.3	10.1	10.1	28

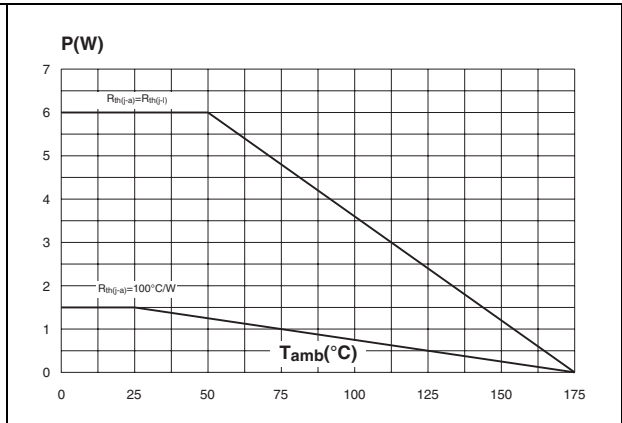
1. Pulse test:  $t_p < 50\text{ ms}$

2.  $\Delta V_{BR} = \alpha T \times (T_{amb} - 25) \times V_{BR}(25^{\circ}C)$

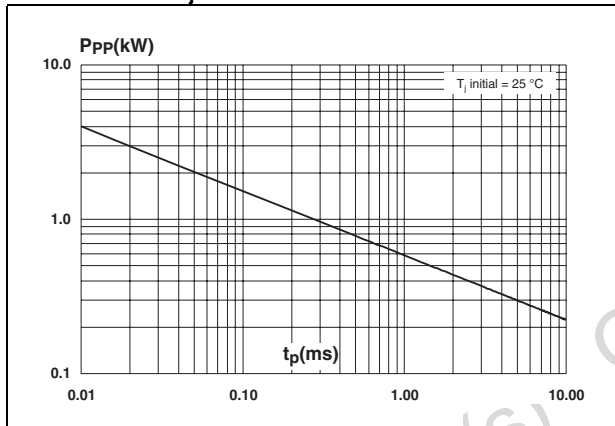
**Figure 1. Peak power dissipation versus initial junction temperature**



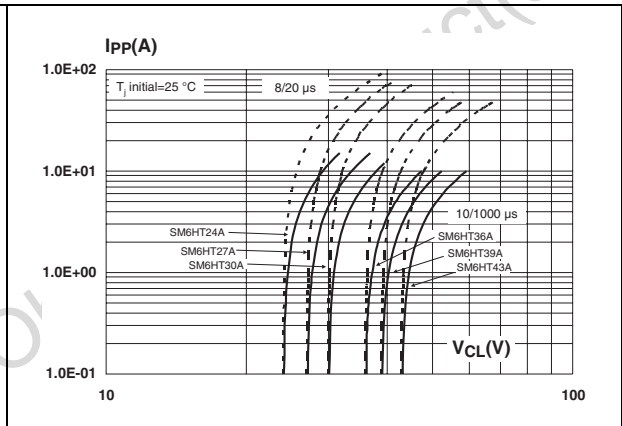
**Figure 2. Continuous power dissipation versus ambient temperature**



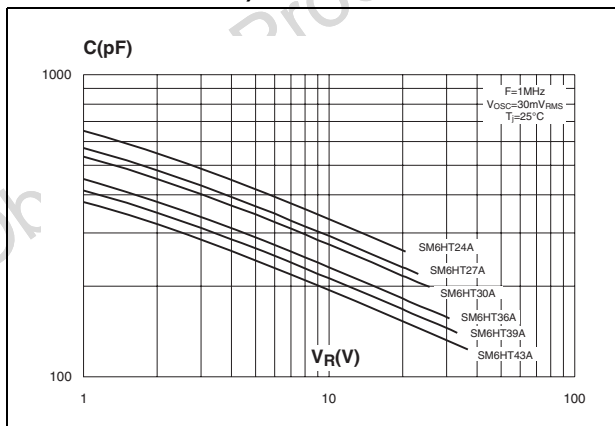
**Figure 3. Peak pulse power versus exponential pulse duration (Tj initial = 25° C)**



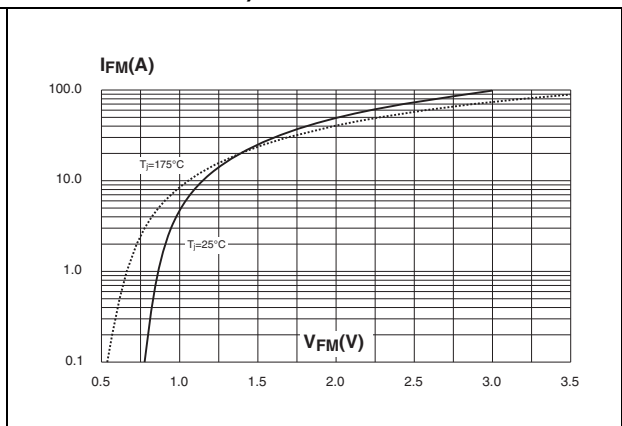
**Figure 4. Clamping voltage versus peak pulse current (Tj initial = 25° C)**



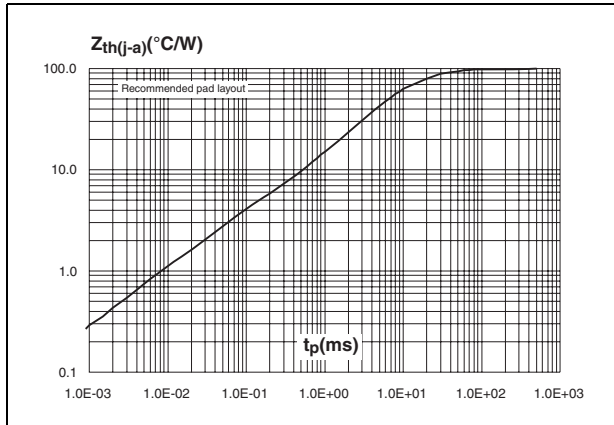
**Figure 5. Junction capacitance versus reverse applied voltage (typical values)**



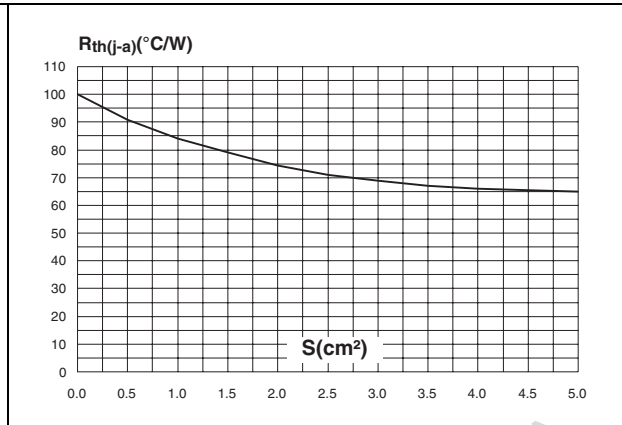
**Figure 6. Peak forward voltage drop versus peak forward current (typical values)**



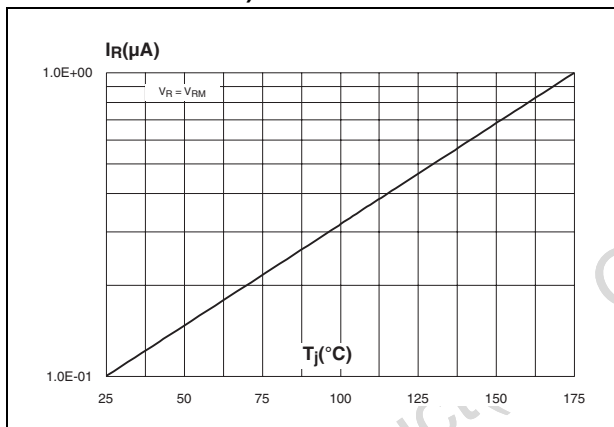
**Figure 7. Variation of thermal impedance junction to ambient versus pulse duration (Printed circuit board FR4 with recommended pad layout)**



**Figure 8. Thermal resistance junction to ambient versus copper surface under each lead (printed circuit board FR4,  $e_{Cu} = 35 \mu m$ )**

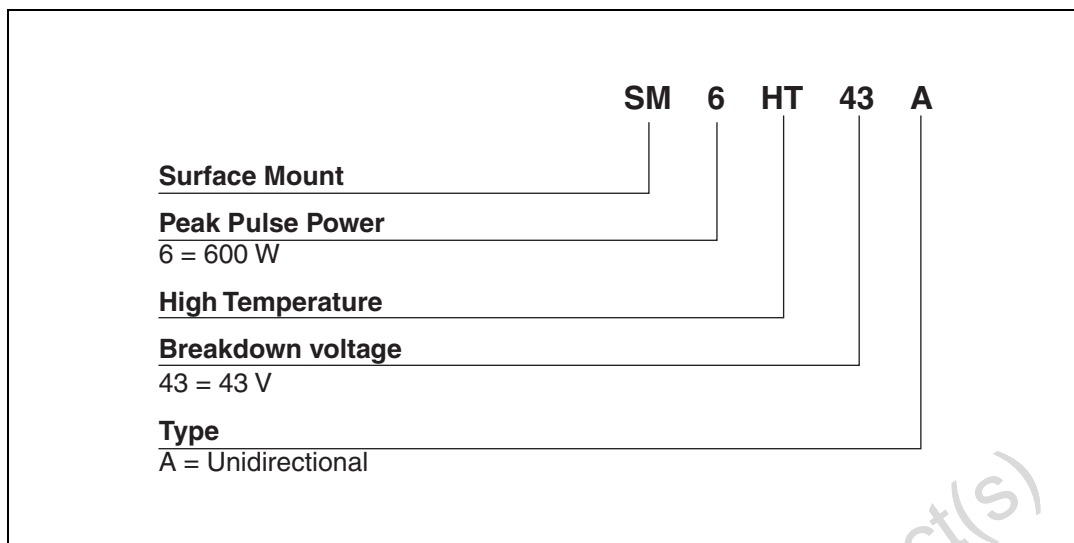


**Figure 9. Variation of leakage current versus junction temperature (typical values)**



Obsolete Product(s)

## 2 Order information scheme



Obsolete Product(s) - Obsolete Product(s)

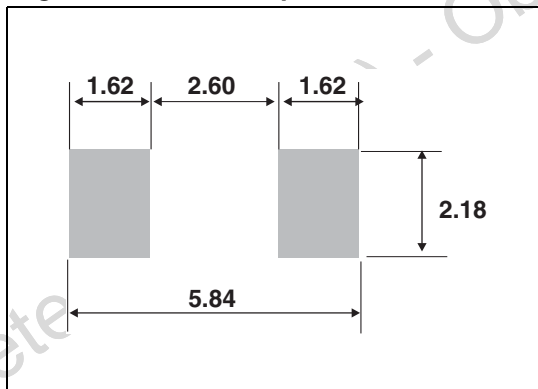
### 3 Package information

- Case: JEDEC DO-214AA molded plastic over Planar junction
- Terminals: Solder plated, solderable per MIL-STD-750, Method 2026
- Polarity: For unidirectional types the band indicates cathode.
- Flammability: Epoxy is rated UL94V-0
- RoHS package

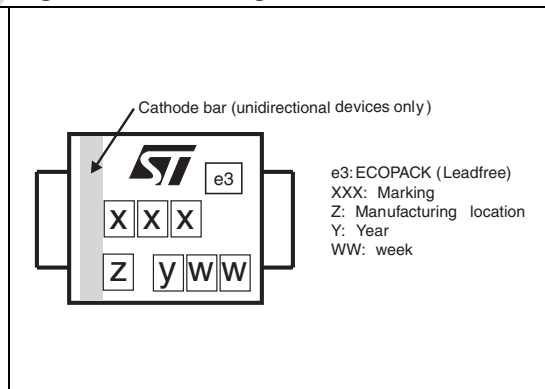
**Table 4. SMB dimensions**

Ref.	Dimensions			
	Millimeters		Inches	
	Min.	Max.	Min.	Max.
A1	1.90	2.45	0.075	0.096
A2	0.05	0.20	0.002	0.008
b	1.95	2.20	0.077	0.087
c	0.15	0.40	0.006	0.016
E	5.10	5.60	0.201	0.220
E1	4.05	4.60	0.159	0.181
D	3.30	3.95	0.130	0.156
L	0.75	1.50	0.030	0.059

**Figure 10. SMB footprint dimensions**



**Figure 11. Marking information**



## 4 Ordering information

Part number	Marking	Package	Weight	Base qty	Delivery mode
SM6HT24A	EMB	SMB	0.12 g	5000	Tape and reel
SM6HT27A	EPB				
SM6HT30A	ERB				
SM6HT36A	EVB				
SM6HT39A	EXB				
SM6HT43A	EYB				

## 5 Revision history

Date	Revision	Changes
Apr-1999	4A	Last release.
26-Jan-2005	5	Figure 9 on page 4: leakage current improved.
18-Mar-2005	6	Table 3: Electrical characteristics ( $T_{amb} = 25^{\circ}C$ ) on page 2: $V_F$ specification added.
21-Mar-2007	7	<a href="#">Table 1 on page 2</a> : Power dissipation upgraded from 5 W to 6 W. <a href="#">Table 3 on page 2</a> : $I_Z$ max parameter added. <a href="#">Figure 2 on page 3</a> : Updated for 6 W power dissipation.

**Please Read Carefully:**

Information in this document is provided solely in connection with ST products. STMicroelectronics NV and its subsidiaries ("ST") reserve the right to make changes, corrections, modifications or improvements, to this document, and the products and services described herein at any time, without notice.

All ST products are sold pursuant to ST's terms and conditions of sale.

Purchasers are solely responsible for the choice, selection and use of the ST products and services described herein, and ST assumes no liability whatsoever relating to the choice, selection or use of the ST products and services described herein.

No license, express or implied, by estoppel or otherwise, to any intellectual property rights is granted under this document. If any part of this document refers to any third party products or services it shall not be deemed a license grant by ST for the use of such third party products or services, or any intellectual property contained therein or considered as a warranty covering the use in any manner whatsoever of such third party products or services or any intellectual property contained therein.

**UNLESS OTHERWISE SET FORTH IN ST'S TERMS AND CONDITIONS OF SALE ST DISCLAIMS ANY EXPRESS OR IMPLIED WARRANTY WITH RESPECT TO THE USE AND/OR SALE OF ST PRODUCTS INCLUDING WITHOUT LIMITATION IMPLIED WARRANTIES OF MERCHANTABILITY, FITNESS FOR A PARTICULAR PURPOSE (AND THEIR EQUIVALENTS UNDER THE LAWS OF ANY JURISDICTION), OR INFRINGEMENT OF ANY PATENT, COPYRIGHT OR OTHER INTELLECTUAL PROPERTY RIGHT.**

**UNLESS EXPRESSLY APPROVED IN WRITING BY AN AUTHORIZED ST REPRESENTATIVE, ST PRODUCTS ARE NOT RECOMMENDED, AUTHORIZED OR WARRANTED FOR USE IN MILITARY, AIR CRAFT, SPACE, LIFE SAVING, OR LIFE SUSTAINING APPLICATIONS, NOR IN PRODUCTS OR SYSTEMS WHERE FAILURE OR MALFUNCTION MAY RESULT IN PERSONAL INJURY, DEATH, OR SEVERE PROPERTY OR ENVIRONMENTAL DAMAGE. ST PRODUCTS WHICH ARE NOT SPECIFIED AS "AUTOMOTIVE GRADE" MAY ONLY BE USED IN AUTOMOTIVE APPLICATIONS AT USER'S OWN RISK.**

Resale of ST products with provisions different from the statements and/or technical features set forth in this document shall immediately void any warranty granted by ST for the ST product or service described herein and shall not create or extend in any manner whatsoever, any liability of ST.

ST and the ST logo are trademarks or registered trademarks of ST in various countries.

Information in this document supersedes and replaces all information previously supplied.

The ST logo is a registered trademark of STMicroelectronics. All other names are the property of their respective owners.

© 2007 STMicroelectronics - All rights reserved

STMicroelectronics group of companies

Australia - Belgium - Brazil - Canada - China - Czech Republic - Finland - France - Germany - Hong Kong - India - Israel - Italy - Japan - Malaysia - Malta - Morocco - Singapore - Spain - Sweden - Switzerland - United Kingdom - United States of America

[www.st.com](http://www.st.com)