



Chipsmall Limited consists of a professional team with an average of over 10 year of expertise in the distribution of electronic components. Based in Hongkong, we have already established firm and mutual-benefit business relationships with customers from,Europe,America and south Asia,supplying obsolete and hard-to-find components to meet their specific needs.

With the principle of “Quality Parts,Customers Priority,Honest Operation,and Considerate Service”,our business mainly focus on the distribution of electronic components. Line cards we deal with include Microchip,ALPS,ROHM,Xilinx,Pulse,ON,Everlight and Freescale. Main products comprise IC,Modules,Potentiometer,IC Socket,Relay,Connector.Our parts cover such applications as commercial,industrial, and automotives areas.

We are looking forward to setting up business relationship with you and hope to provide you with the best service and solution. Let us make a better world for our industry!



## Contact us

Tel: +86-755-8981 8866 Fax: +86-755-8427 6832

Email & Skype: info@chipsmall.com Web: www.chipsmall.com

Address: A1208, Overseas Decoration Building, #122 Zhenhua RD., Futian, Shenzhen, China



DO NOT SCALE FROM THIS PRINT

| TABLE 1 |             |                      |
|---------|-------------|----------------------|
| ITEM    | COMPONENT   | -GF                  |
| 1       | BODY        | SMA-J-P-F-RA-SM1-BDY |
| 2       | SOCKET      | SMA-J-P-G-RA-SM1-SKT |
| 3       | SHELL       | SMA-J-P-F-RA-SM1-SHL |
| 4       | INSULATOR 1 | SMA-INS-024          |
| 5       | INSULATOR 2 | SMA-INS-023          |

**Pb** THIS PRODUCT MANUFACTURED WITH LEAD-FREE PROCESSING

DESIGNED & DIMENSIONED IN MILLIMETERS [INCHES]

SMA-J-P-XX-RA-SM1

GENDER -J: JACK  
 TYPE -P: PCB  
 TERMINATION -SM1: SURFACE MOUNT  
 ORIENTATION -RA: RIGHT ANGLE

PLATING SPECIFICATION  
 -GF: 10μ" GOLD CENTER CONTACT, 3μ" GOLD OUTER CONTACT (SEE TABLE 1)

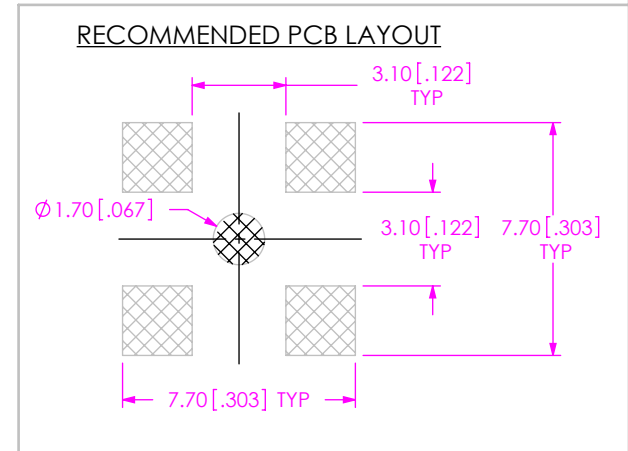
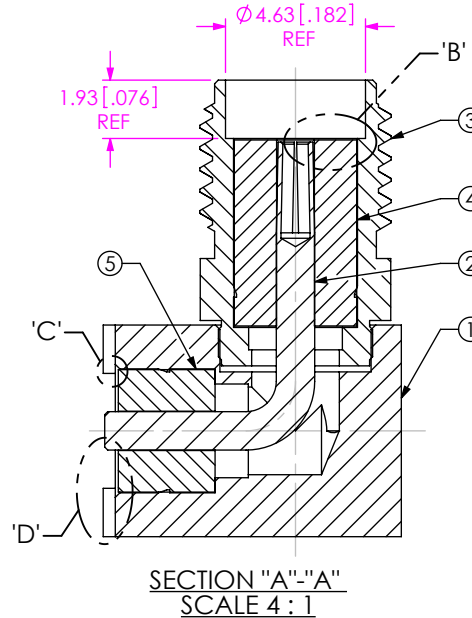
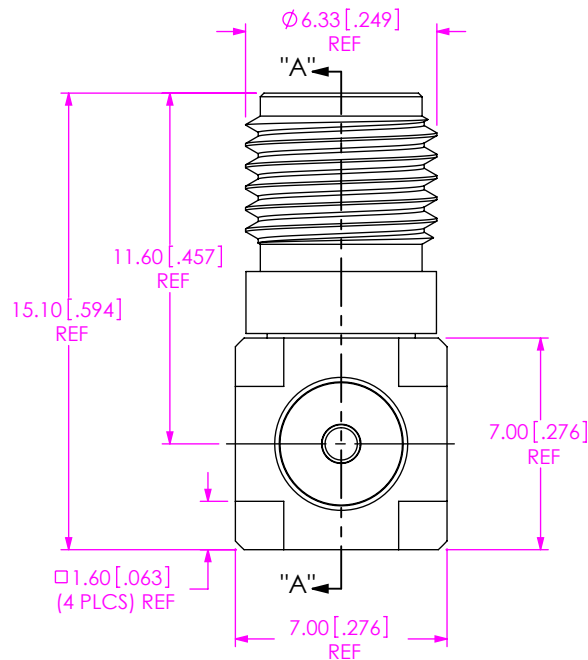
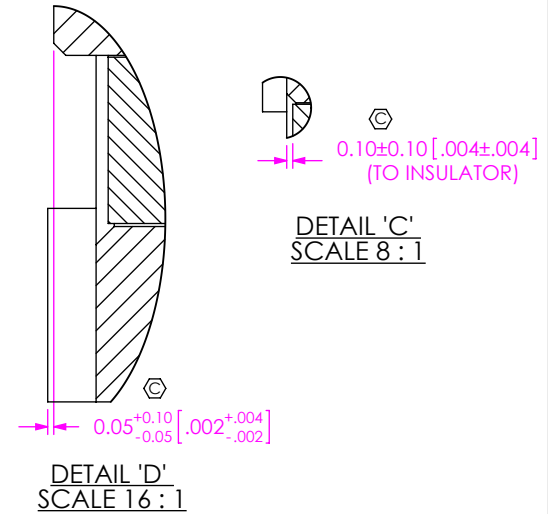
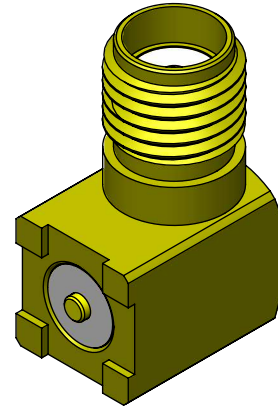
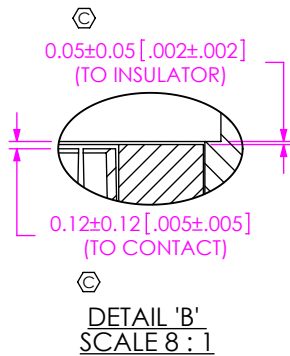
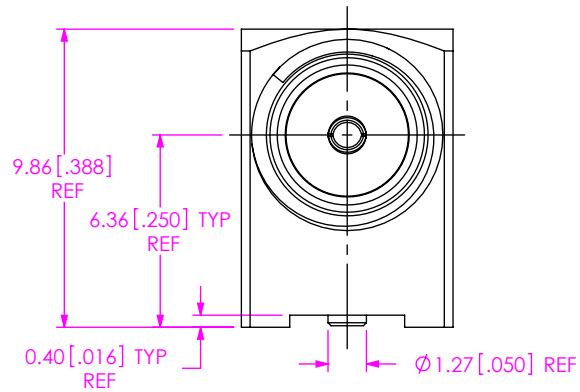

NOTES:

- ⊗ REPRESENTS A CRITICAL DIMENSION.
- PRODUCT TO BE PACKAGED PER PACKAGING STANDARD CO-RF-WI-3040-M. TRAY: TY-SMA001-1; COVER: TY-SMA-001-2.
- NOTE DELETED.
- NOTE DELETED.
- NOTE DELETED.

UNLESS OTHERWISE SPECIFIED, DIMENSIONS ARE IN MILLIMETERS. TOLERANCES ARE:  
 DECIMALS ANGLES  
 X.X: ±0.3 [.01] 5°  
 X.XX: ±0.13 [.005]  
 X.XXX: ±0.051 [.0020]

PROPRIETARY NOTE  
 THIS DOCUMENT CONTAINS INFORMATION CONFIDENTIAL AND PROPRIETARY TO SAMTEC, INC. AND SHALL NOT BE REPRODUCED OR TRANSFERRED TO OTHER DOCUMENTS OR DISCLOSED TO OTHERS OR USED FOR ANY PURPOSE OTHER THAN THAT WHICH IT WAS OBTAINED WITHOUT THE EXPRESSED WRITTEN CONSENT OF SAMTEC, INC.

MATERIAL: DO NOT SCALE DRAWING SHEET SCALE: 5:1  
 BODY, SHELL: BRASS  
 CONTACT: COPPER ALLOY  
 DIELECTRIC: PTFE



520 PARK EAST BLVD, NEW ALBANY, IN 47150  
 PHONE: 812-944-6733 FAX: 812-948-5047  
 e-Mail: info@SAMTEC.com code 55322

DESCRIPTION: SMA RIGHT ANGLE, JACK, 50 OHM

DWG. NO. SMA-J-P-XX-RA-SM1

BY: ALVIN W 9/10/2010 SHEET 1 OF 2

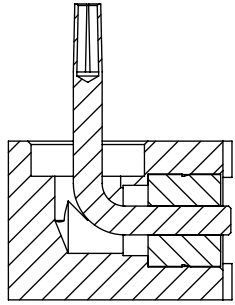

**IN-PROCESS 1**  
INSERT CONTACT & INSULATOR

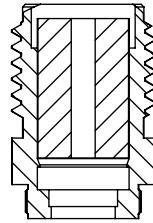

**IN-PROCESS 2**  
ADD INSULATOR(2)

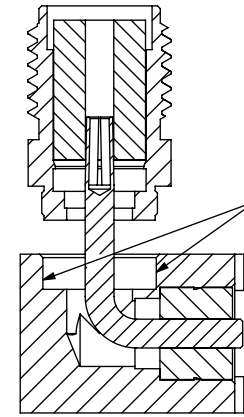

ADD ADHESIVE AROUND ENTER CIRCUMFERENCE USE LOCTITE 638 RETAINING COMPOUND

**IN-PROCESS 3**  
ADD ADHESIVE TO BODY

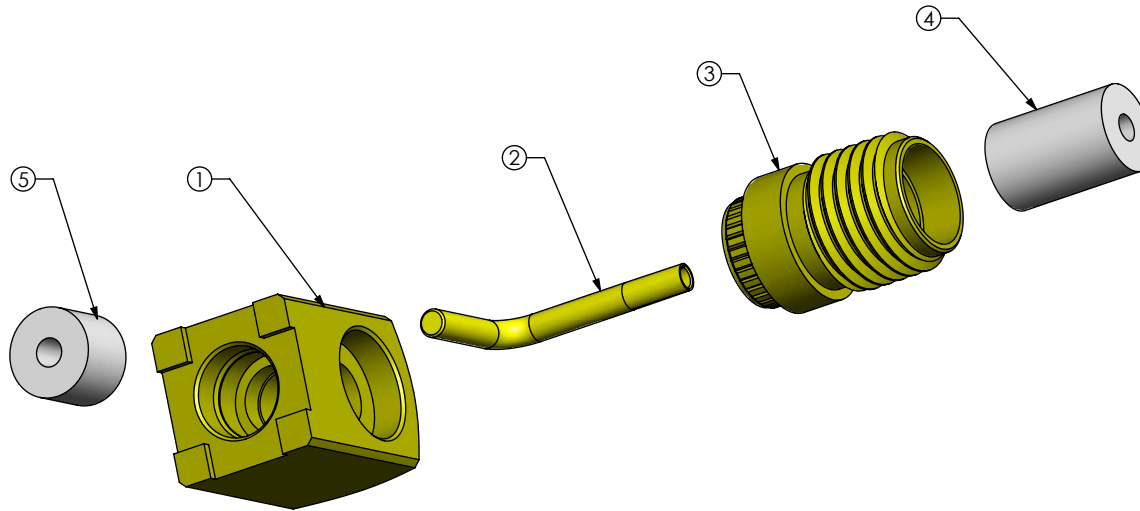

**PROPRIETARY NOTE**  
THIS DOCUMENT CONTAINS INFORMATION CONFIDENTIAL AND PROPRIETARY TO SAMTEC, INC. AND SHALL NOT BE REPRODUCED OR TRANSFERRED TO OTHER DOCUMENTS OR DISCLOSED TO OTHERS OR USED FOR ANY PURPOSE OTHER THAN THAT WHICH IT WAS OBTAINED WITHOUT THE EXPRESSED WRITTEN CONSENT OF SAMTEC, INC.

DO NOT SCALE DRAWING

SHEET SCALE: 3:1



520 PARK EAST BLVD, NEW ALBANY, IN 47150  
PHONE: 812-944-6733 FAX: 812-948-5047  
e-Mail info@SAMTEC.com code 55322

DESCRIPTION:  
SMA RIGHT ANGLE, JACK, 50 OHM

DWG. NO.  
**SMA-J-P-XX-RA-SM1**

BY: ALVIN W 9/10/2010 SHEET 2 OF 2