



Chipsmall Limited consists of a professional team with an average of over 10 year of expertise in the distribution of electronic components. Based in Hongkong, we have already established firm and mutual-benefit business relationships with customers from,Europe,America and south Asia,supplying obsolete and hard-to-find components to meet their specific needs.

With the principle of "Quality Parts,Customers Priority,Honest Operation,and Considerate Service",our business mainly focus on the distribution of electronic components. Line cards we deal with include Microchip,ALPS,ROHM,Xilinx,Pulse,ON,Everlight and Freescale. Main products comprise IC,Modules,Potentiometer,IC Socket,Relay,Connector.Our parts cover such applications as commercial,industrial, and automotives areas.

We are looking forward to setting up business relationship with you and hope to provide you with the best service and solution. Let us make a better world for our industry!



Contact us

Tel: +86-755-8981 8866 Fax: +86-755-8427 6832

Email & Skype: info@chipsmall.com Web: www.chipsmall.com

Address: A1208, Overseas Decoration Building, #122 Zhenhua RD., Futian, Shenzhen, China



Absolute maximum ratings

($T_a=25^\circ\text{C}$)

Symbol	Ratings	Unit
V_{CB0}	120	V
V_{CEO}	100	V
V_{EBO}	6	V
I_C	3	A
I_{CP}	5 (PW \leq 1ms, $D_u\leq$ 50%)	A
I_B	0.2	A
P_T	4 ($T_a=25^\circ\text{C}$)	W
	20 ($T_c=25^\circ\text{C}$)	
T_j	150	$^\circ\text{C}$
T_{stg}	-40 to +150	$^\circ\text{C}$

Electrical characteristics

($T_a=25^\circ\text{C}$)

Symbol	Specification			Unit	Conditions
	min	typ	max		
I_{CBO}			10	μA	$V_{CB}=120\text{V}$
I_{EBO}			10	mA	$V_{EB}=6\text{V}$
V_{CEO}	100			V	$I_C=25\text{mA}$
h_{FE}	2000	6000	15000		$V_{CE}=4\text{V}$, $I_C=1.5\text{A}$
$V_{CE(sat)}$		1.1	1.5	V	$I_C=1.5\text{A}$, $I_B=3\text{mA}$
$V_{BE(sat)}$		1.7	2.0	V	
t_{on}		0.5		μs	$V_{CC}\approx 30\text{V}$
t_{stg}		2.2		μs	$I_C=1.5\text{A}$
t_f		0.9		μs	$I_{B1}=-I_{B2}=3\text{mA}$
f_T		40		MHz	$V_{CE}=12\text{V}$, $I_E=-0.5\text{A}$
C_{ob}		30		pF	$V_{CB}=10\text{V}$, $f=1\text{MHz}$

Equivalent circuit diagram

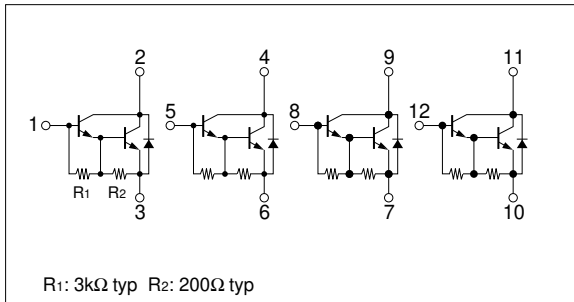

Characteristic curves

I_C - V_{CE} Characteristics (Typical)

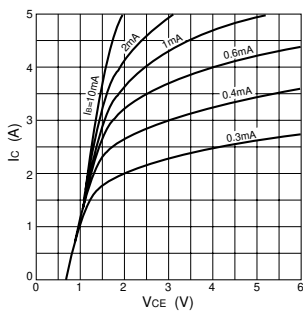

h_{FE} - I_C Characteristics (Typical)

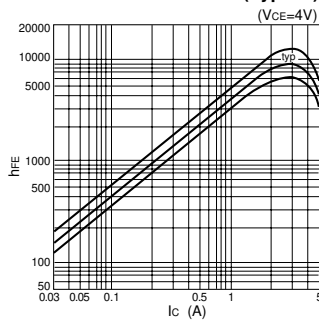

h_{FE} - I_C Temperature Characteristics (Typical)

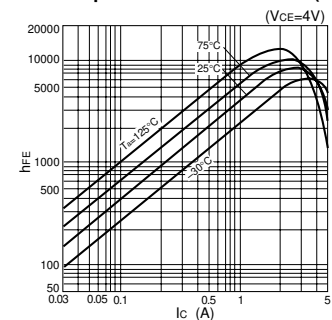

$V_{CE(sat)}$ - I_C Temperature Characteristics (Typical)

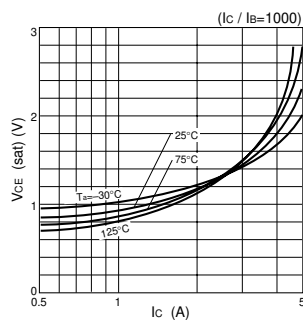

$V_{CE(sat)}$ - I_B Characteristics (Typical)

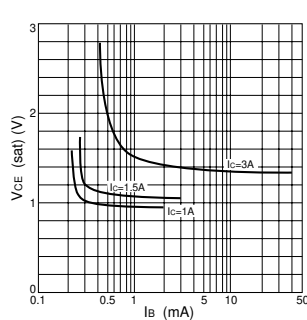

I_C - V_{BE} Temperature Characteristics (Typical)

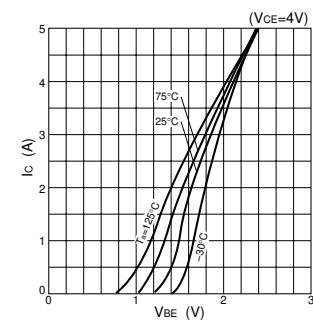

θ_{j-a} -PW Characteristics

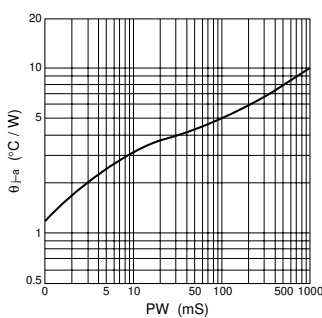

P_T - T_a Characteristics

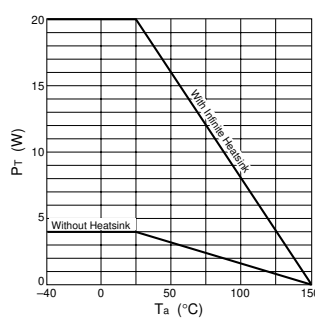

Safe Operating Area (SOA)

