



Chipsmall Limited consists of a professional team with an average of over 10 year of expertise in the distribution of electronic components. Based in Hongkong, we have already established firm and mutual-benefit business relationships with customers from,Europe,America and south Asia,supplying obsolete and hard-to-find components to meet their specific needs.

With the principle of “Quality Parts,Customers Priority,Honest Operation,and Considerate Service”,our business mainly focus on the distribution of electronic components. Line cards we deal with include Microchip,ALPS,ROHM,Xilinx,Pulse,ON,Everlight and Freescale. Main products comprise IC,Modules,Potentiometer,IC Socket,Relay,Connector.Our parts cover such applications as commercial,industrial, and automotives areas.

We are looking forward to setting up business relationship with you and hope to provide you with the best service and solution. Let us make a better world for our industry!



## Contact us

Tel: +86-755-8981 8866 Fax: +86-755-8427 6832

Email & Skype: info@chipsmall.com Web: www.chipsmall.com

Address: A1208, Overseas Decoration Building, #122 Zhenhua RD., Futian, Shenzhen, China



## Fully integrated GPS LNA IC

### Features

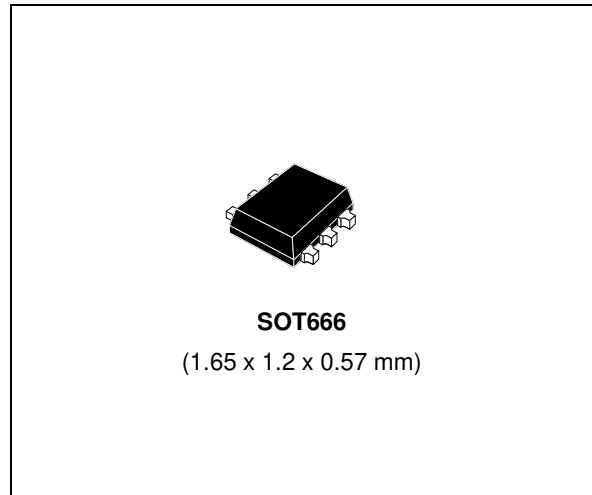
- Power down function
- Integrated matching networks
- Low noise figure 1.15 dB @ 1.575 GHz
- High gain 18 dB @ 1.575 GHz
- High linearity (IIP3 = +3 dBm)
- Temperature compensated
- Unconditionally stable
- ESD protection (HBM  $\pm$  2 kV)
- 70 GHz Silicon Germanium technology

### Applications

- GPS

### Description

The SMA661AS is the first low-noise amplifier with integrated matching networks and embedded power-down function. The chip, which requires only one external input capacitor, drastically reduces the application bill of materials and the PCB area, resulting in an ideal solution for compact and cost-effective GPS LNA.



The SMA661AS, using the ST's leading-edge 70 GHz SiGe BiCMOS technology, achieves excellent RF performance at the GPS frequency of 1.575 GHz, in terms of power gain, noise Figure and linearity with a current consumption of 8.5 mA.

The device is unconditionally stable and ESD protected. All these features are steady over the operating temperature range of -40 °C to +85 °C. It's housed in ultra-miniature SOT666 plastic package.

**Table 1. Device summary**

Order code	Marking	Package	Packing
SMA661ASTR	661	SOT666	Tape and reel

---

# Contents

<b>1</b>	<b>Pins description and circuit schematic</b> .....	<b>3</b>
<b>2</b>	<b>Electrical specifications</b> .....	<b>4</b>
2.1	Absolute maximum ratings .....	4
2.2	Electrical characteristics .....	4
<b>3</b>	<b>Typical performance</b> .....	<b>5</b>
<b>4</b>	<b>Evaluation board description</b> .....	<b>8</b>
<b>5</b>	<b>Package and packing informations</b> .....	<b>10</b>
5.1	Package informations .....	10
5.2	Packing informations .....	11
<b>6</b>	<b>Revision history</b> .....	<b>13</b>

# 1 Pins description and circuit schematic

Table 2. Pins description

Pin #	Pin name
1	RF IN
2	GND
3	PD
4	RF OUT
5	GND
6	V <sub>CC</sub>

Figure 1. Pin connection

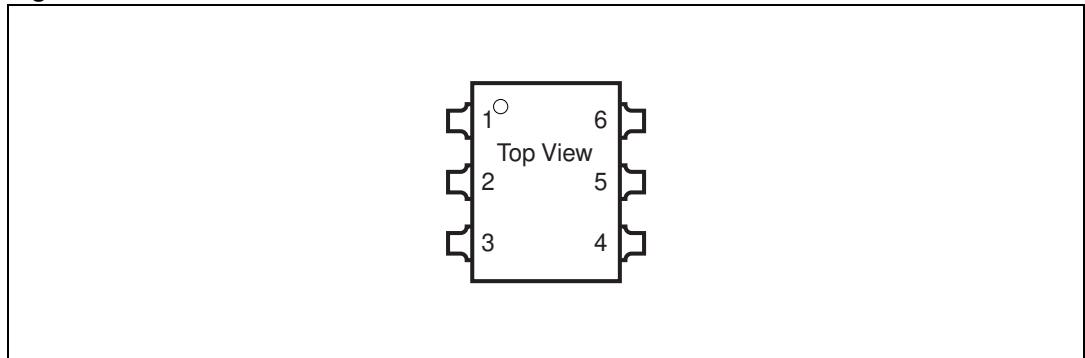
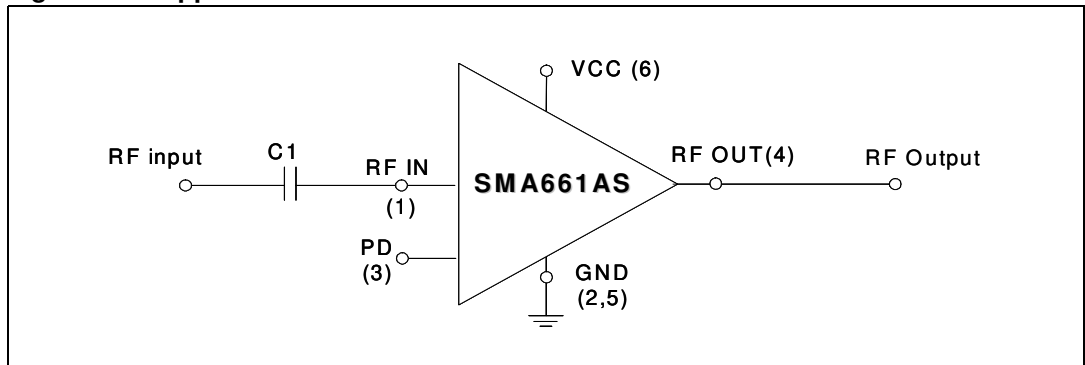


Figure 2. Application circuit schematic



## 2 Electrical specifications

### 2.1 Absolute maximum ratings

**Table 3. Absolute maximum ratings**

Symbol	Parameter	Conditions	Value	Unit
$V_{CC}$	Supply voltage		3.3	V
$T_{stg}$	Storage temperature		-60 to +150	°C
$T_a$	Operating ambient temperature		-40 to +85	°C
$V_{ESD}$	Electrostatic discharge	HBM (ALL PINs)	± 2000	V
$V_{ESD}$	Electrostatic discharge	MM (ALL PINs)	± 200	V

### 2.2 Electrical characteristics

( $T_a = +25$  °C,  $V_{CC} = 2.7$  V,  $Z_L = Z_S = 50$  ohm, unless otherwise specified; measured according to [Figure 13](#) at pin level)

**Table 4. Electrical characteristics**

Symbol	Parameters	Test conditions	Min.	Typ.	Max.	Unit
f	Frequency			1575		MHz
$V_{CC}$	Supply voltage		2.4	2.7	3	V
$I_{CC}$	Current consumption			8.5		mA
$I_{PD}$	Power down mode current consumption	$V_{PD} \leq V_{PDL}$		10		nA
$G_p$	Power gain			18		dB
NF	Noise figure			1.15		dB
IIP2	Input IP2	f1 = 849 MHz, f2 = 2424 MHz, Pin = -30 dBm		0.5		dBm
IIP3	Input IP3	f1 = 1574.5 MHz, f2 = 1575.5 MHz, Pin = -30 dBm		3		dBm
ISL	Reverse Isolation			-28		dB
RLin	Input return loss	f = 1500-1650 MHz		10		dB
RLout	Output return loss	f = 1500-1650 MHz		10		dB
$V_{PDL}^{(1)}$	Power down low state				0.5	V
$V_{PDH}^{(2)}$	Power down high state		1.0		$V_{CC}$	V
Stability		100 - 10000 MHz	Unconditionally stable			

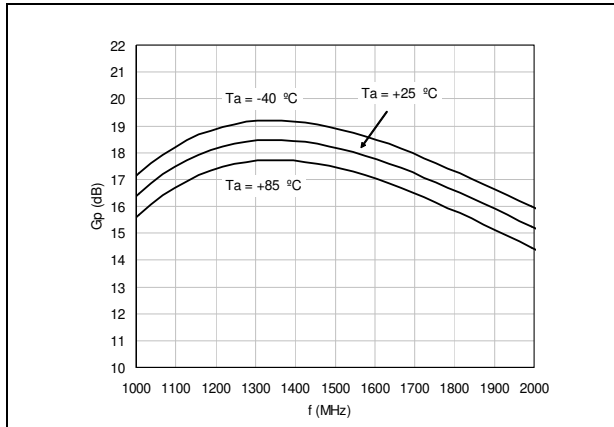
1. The device is switched to OFF state

2. The device is switched to ON state

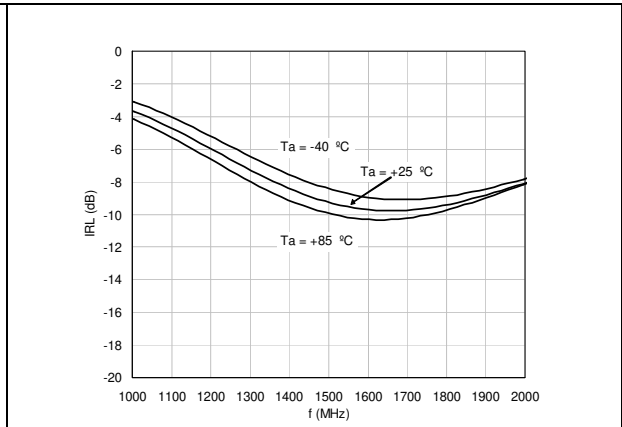
### 3 Typical performance

( $V_{cc} = 2.7\text{ V}$ ,  $Z_L = Z_S = 50\text{ ohm}$ , unless otherwise specified; measured according to [Figure 13](#) at pin level)

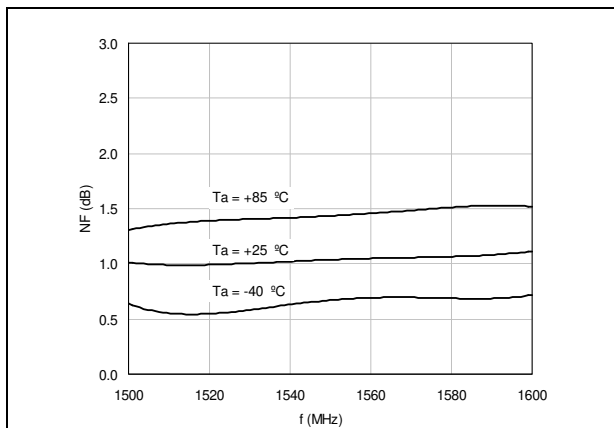
**Figure 3. Power gain vs. frequency**



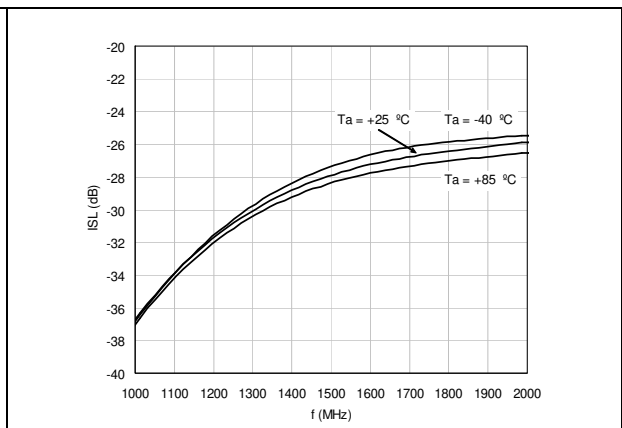
**Figure 4. Input return loss vs. frequency**



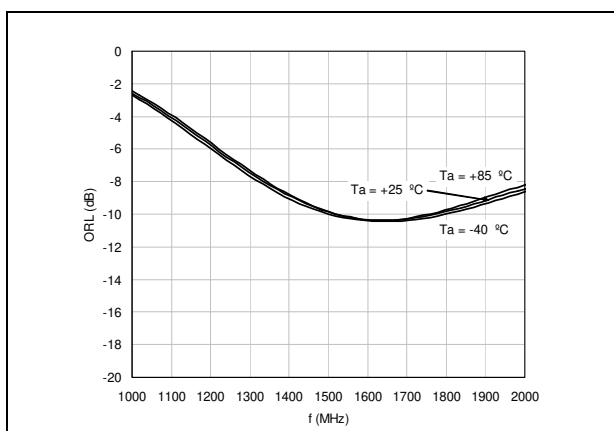
**Figure 5. Noise figure vs. frequency**



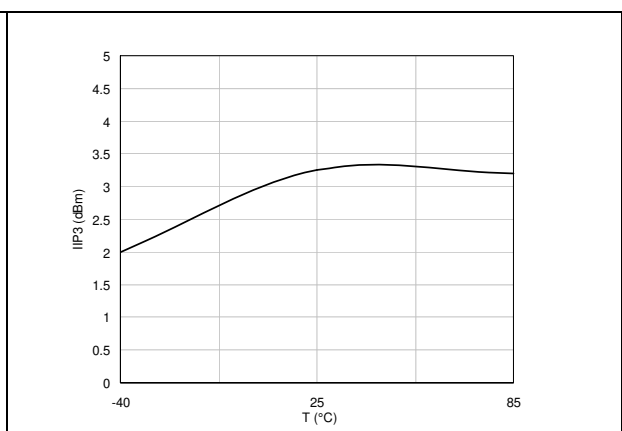
**Figure 6. Reverse isolation vs. frequency**



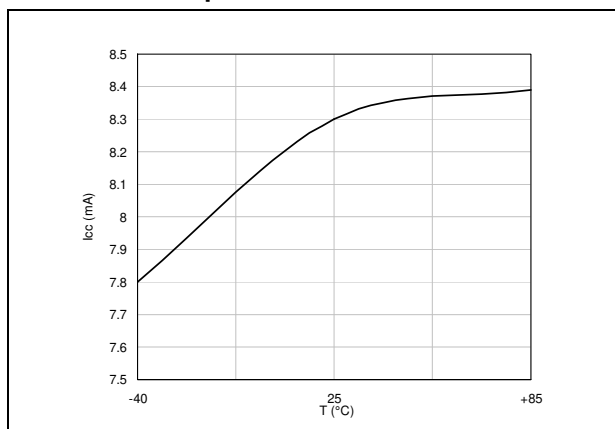
**Figure 7. Output return loss vs. frequency**



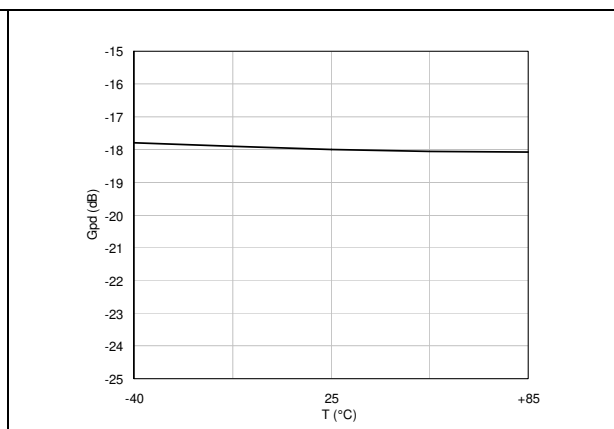
**Figure 8. IIP3 vs. temperature**



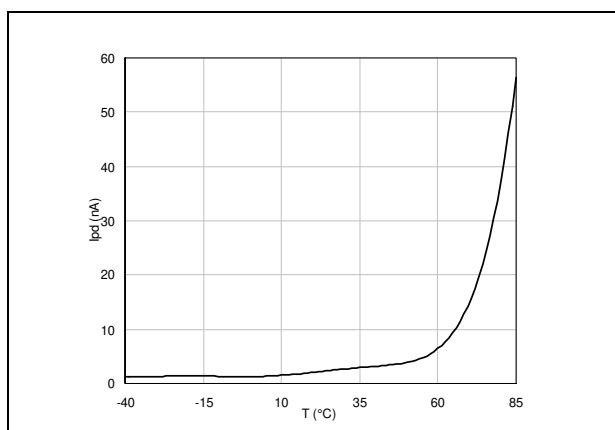
**Figure 9. Current consumption vs. temperature**



**Figure 10. Gain power down vs. temperature**

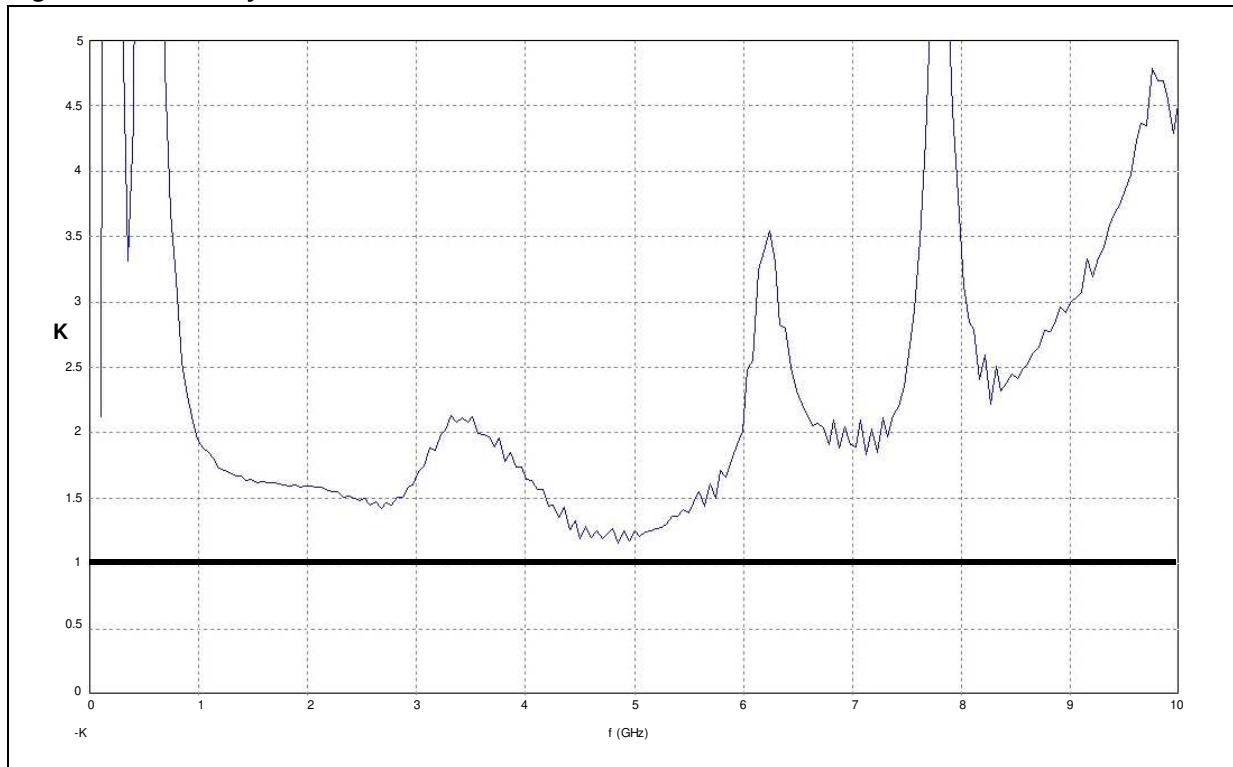


**Figure 11. Power down current vs. temperature**



Note: S-Parameter are available on request.

Figure 12. Stability





## 4 Evaluation board description

Figure 13. Evaluation board

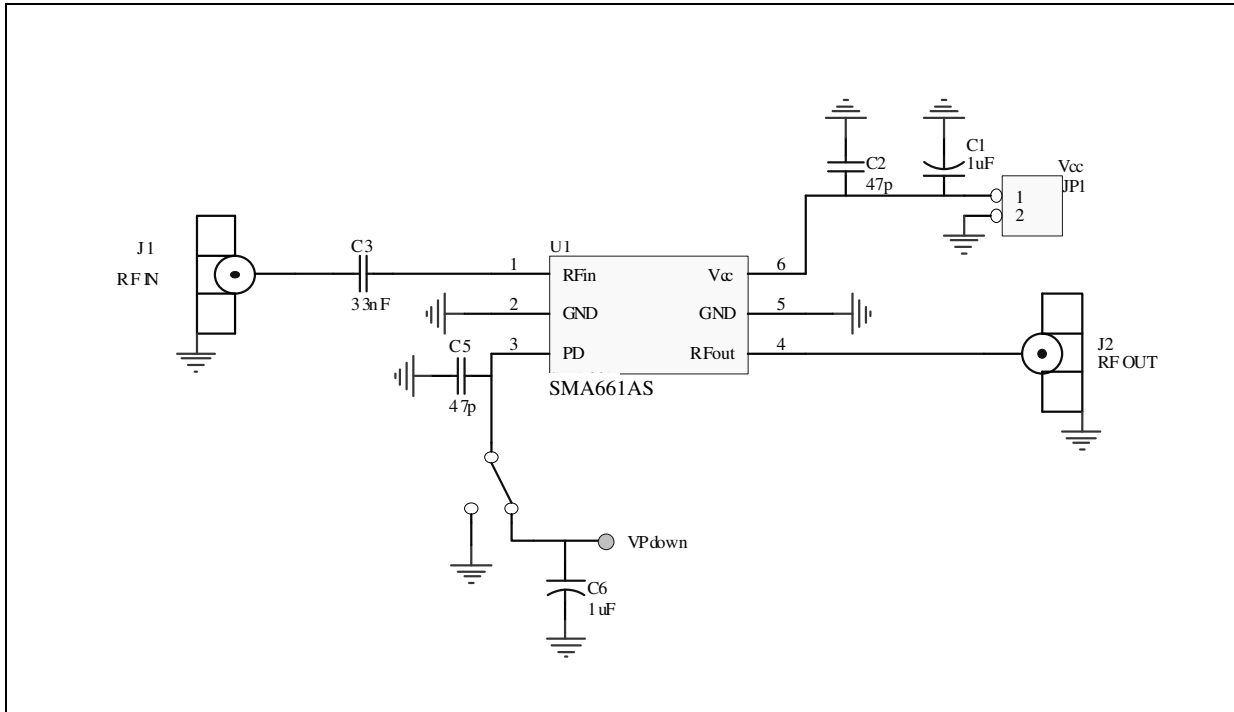


Table 5. Evaluation board bill of material

Component	Value	Type	Manufacturer	Function
C1	1 $\mu$ F (electrolytic)	Case_A	Various	Supply Filter
C2	47 pF	0603	Murata (GRM188)	RF Bypass
C3	33 nF	0603	Murata (GRM188)	Input dc block / IIP3 improvement
C5	47 pF	0603	Murata (GRM188)	RF Bypass
C6	1 $\mu$ F (electrolytic)	Case_A	Various	Supply Filter
J1	-	142-0711-841 (SMA_Female)	Johnson	RF Input connector
J2	-	142-0711-841 (SMA_Female)	Johnson	RF Output connector
U1	-	SOT666	STMicroelectronics	SMA661AS GPS LNA
Substrate	-	FR4 18 mm x 20 mm x 1.1 mm	Various	Layer = 3 (see <a href="#">Figure 14</a> & <a href="#">15</a> )

Figure 14. Evaluation Board Layout

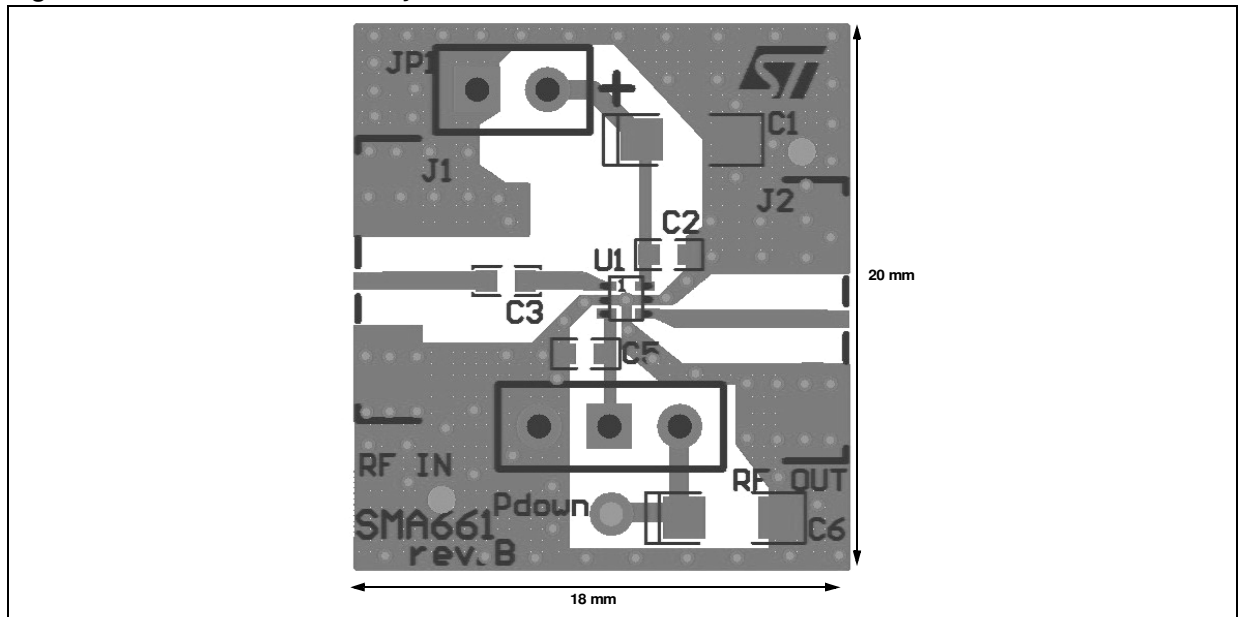
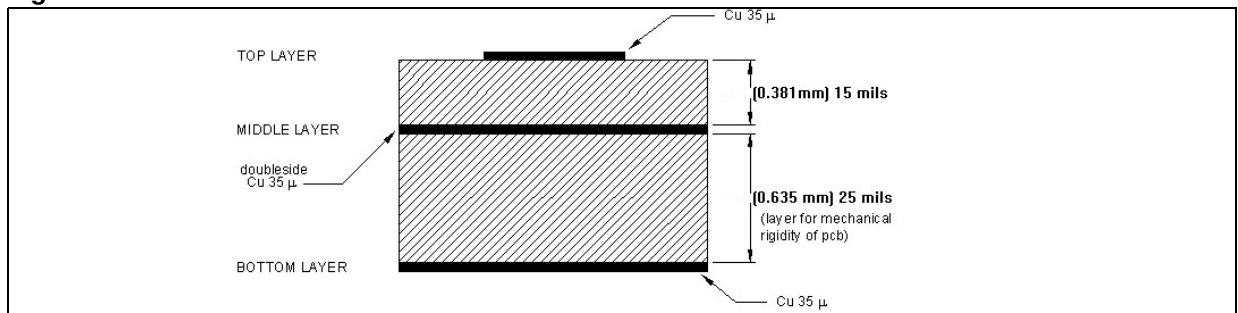


Figure 15. Evaluation board cross section



*Note:* Gerber files of the SMA661AS evaluation board are available on request.

#### Layout recommendation:

Both lines from pin 2 and pin 5 to GND plane have to be as short as possible to maximize the performances. Therefore a via hole under the IC is highly recommended.

## 5 Package and packing informations

### 5.1 Package informations

In order to meet environmental requirements, ST offers these devices in different grades of ECOPACK® packages, depending on their level of environmental compliance. ECOPACK® specifications, grade definitions and product status are available at: [www.st.com](http://www.st.com).

ECOPACK® is an ST trademark.

**Table 6. SOT666 (Lead-free) mechanical data**

DIM.	mm.		
	MIN.	TYP	MAX.
A	0.45		0.60
A3	0.08		0.18
b	0.17		0.27
b1		0.27	0.34
D	1.50		1.70
E	1.50		1.70
E1	1.10		1.30
e		0.50	
L1		0.19	
L2	0.10		0.30
L3		0.10	

**Figure 16. SOT666 (Lead-free) package outline**

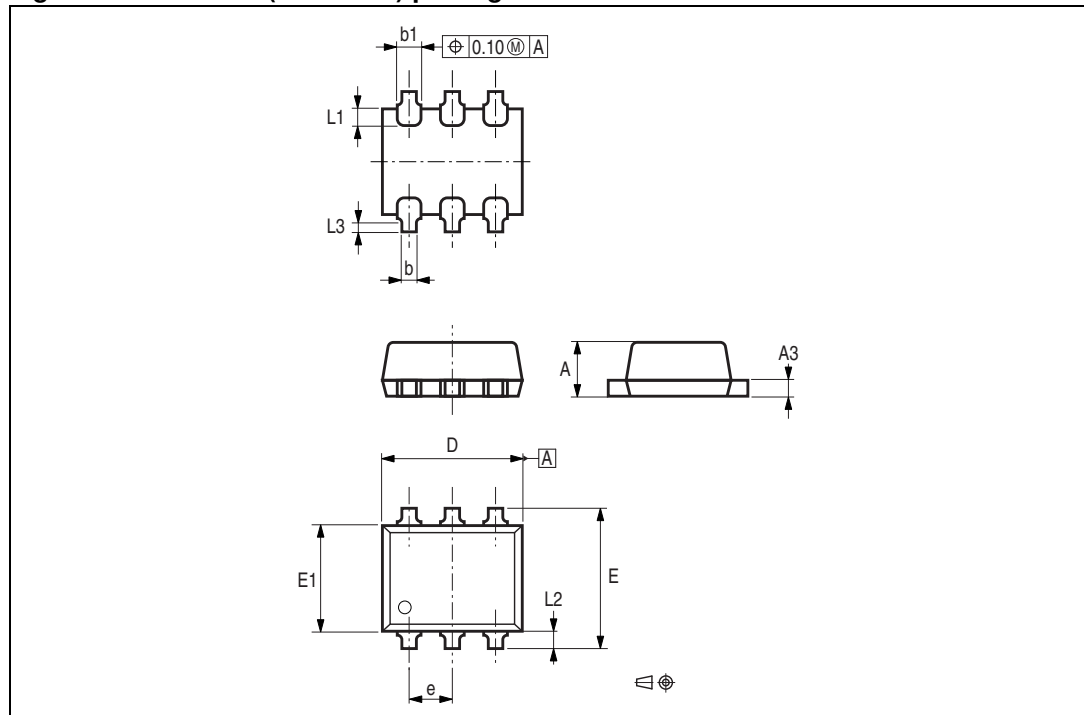
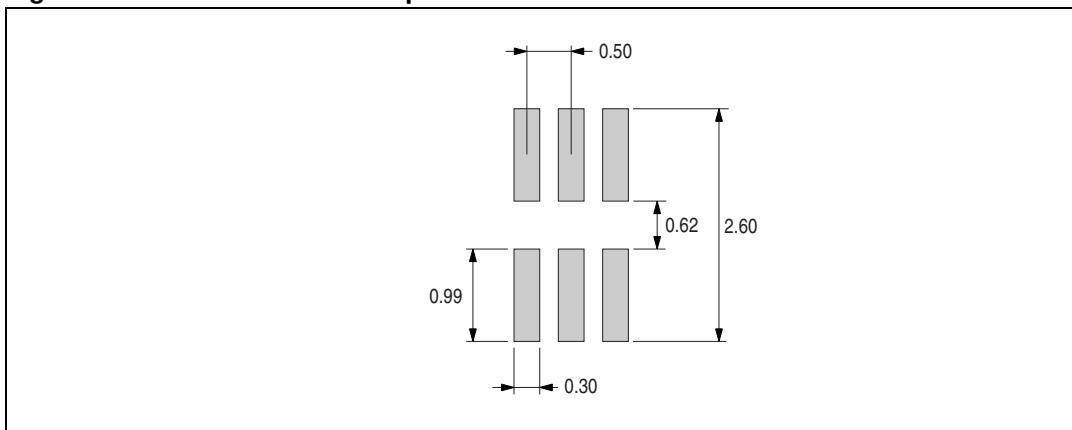


Figure 17. Recommended footprint



## 5.2 Packing informations

Figure 18. Reel description

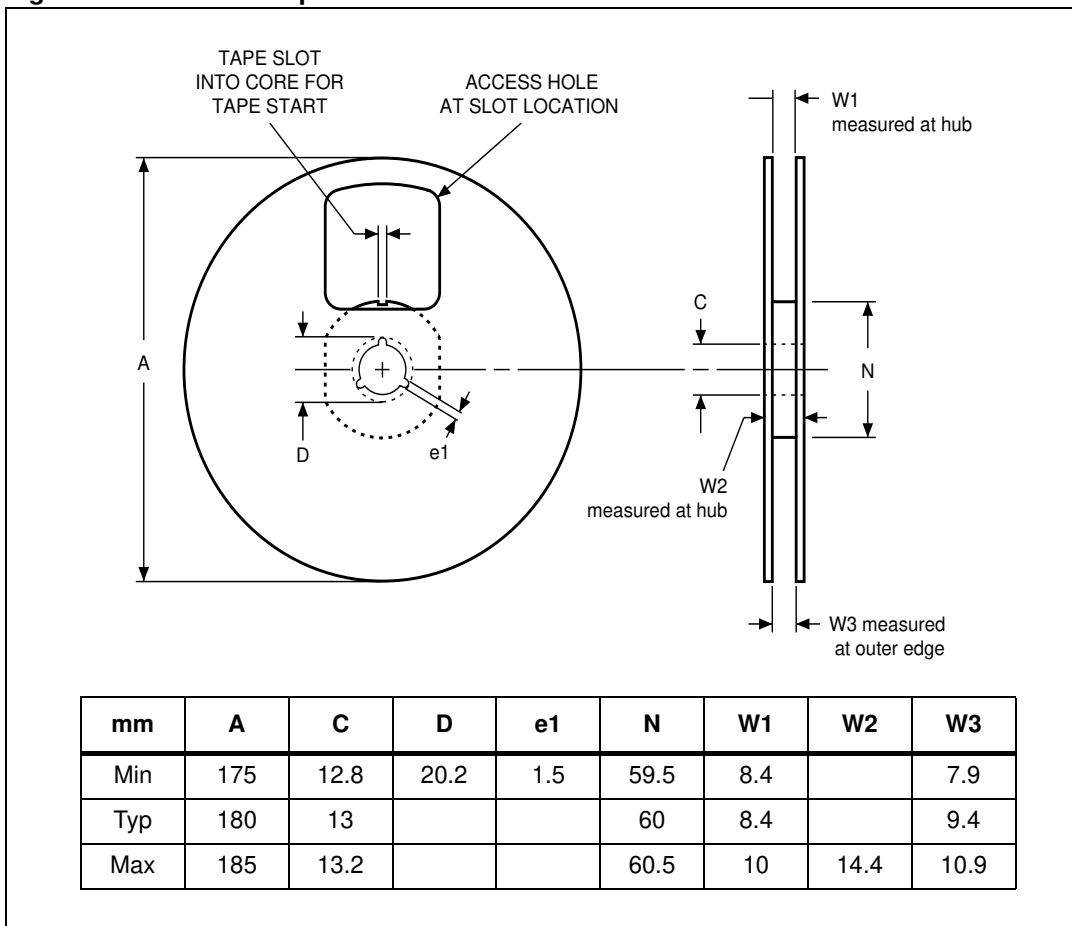


Figure 19. Carrier tape requirements

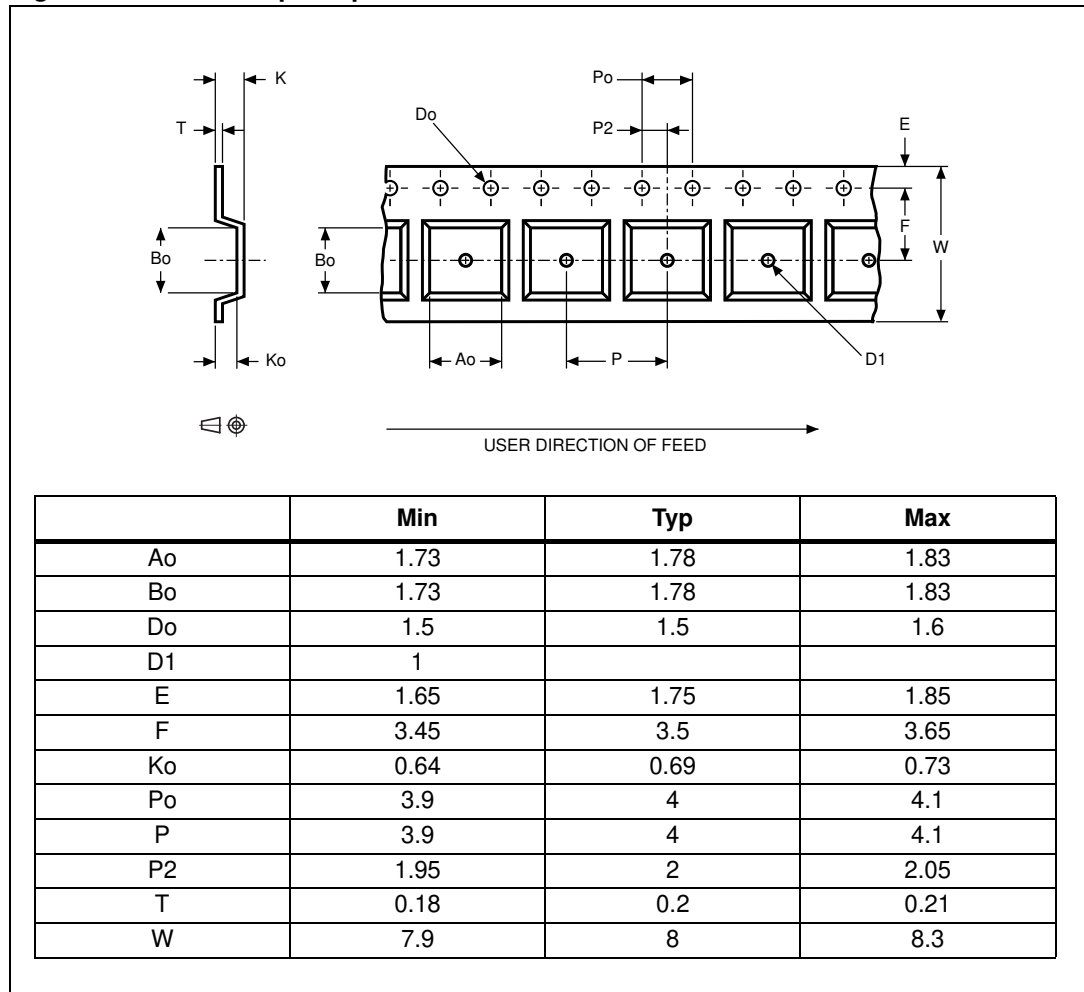
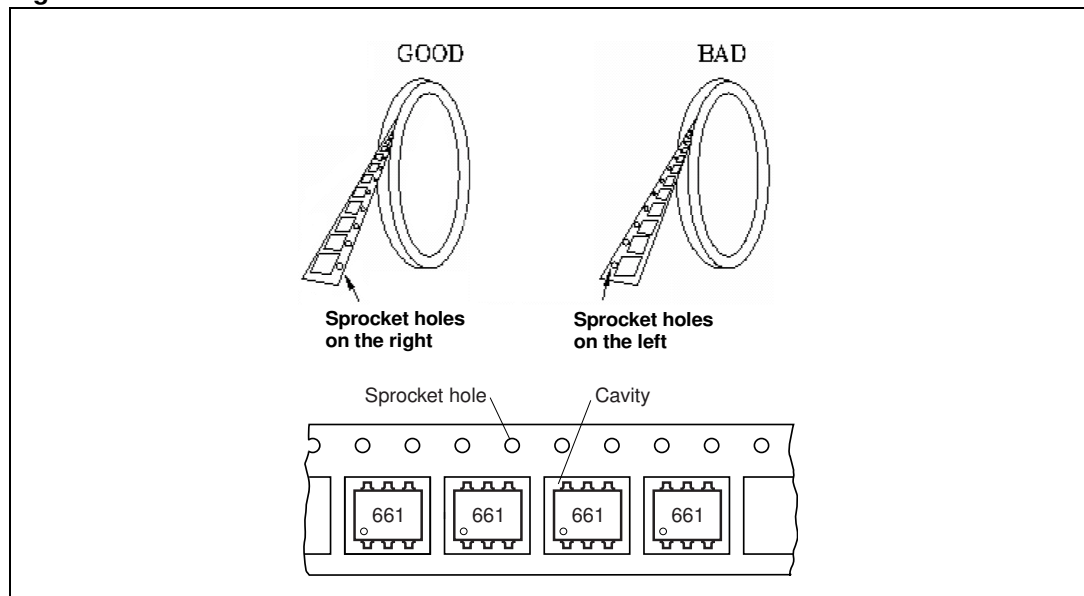


Figure 20. Device orientation



## 6 Revision history

**Table 7. Document revision history**

Date	Revision	Changes
15-Jul-2005	1	Initial release.
20-Oct-2005	2	Added: Evaluation Board Schematic & Layout.
07-Jul-2006	3	Changed to new template. Added packing informations.
04-Apr-2007	4	Updated noise figure and high gain values. Updated <a href="#">Figure 3</a> and <a href="#">Figure 5</a> .
27-Mar-2009	5	Added max. value to the parameter “V <sub>PDH</sub> ” in <a href="#">Table 4: Electrical characteristics</a> .
23-Sep-2013	6	Updated Disclaimer.

**Please Read Carefully:**

Information in this document is provided solely in connection with ST products. STMicroelectronics NV and its subsidiaries ("ST") reserve the right to make changes, corrections, modifications or improvements, to this document, and the products and services described herein at any time, without notice.

All ST products are sold pursuant to ST's terms and conditions of sale.

Purchasers are solely responsible for the choice, selection and use of the ST products and services described herein, and ST assumes no liability whatsoever relating to the choice, selection or use of the ST products and services described herein.

No license, express or implied, by estoppel or otherwise, to any intellectual property rights is granted under this document. If any part of this document refers to any third party products or services it shall not be deemed a license grant by ST for the use of such third party products or services, or any intellectual property contained therein or considered as a warranty covering the use in any manner whatsoever of such third party products or services or any intellectual property contained therein.

**UNLESS OTHERWISE SET FORTH IN ST'S TERMS AND CONDITIONS OF SALE ST DISCLAIMS ANY EXPRESS OR IMPLIED WARRANTY WITH RESPECT TO THE USE AND/OR SALE OF ST PRODUCTS INCLUDING WITHOUT LIMITATION IMPLIED WARRANTIES OF MERCHANTABILITY, FITNESS FOR A PARTICULAR PURPOSE (AND THEIR EQUIVALENTS UNDER THE LAWS OF ANY JURISDICTION), OR INFRINGEMENT OF ANY PATENT, COPYRIGHT OR OTHER INTELLECTUAL PROPERTY RIGHT.**

**ST PRODUCTS ARE NOT DESIGNED OR AUTHORIZED FOR USE IN: (A) SAFETY CRITICAL APPLICATIONS SUCH AS LIFE SUPPORTING, ACTIVE IMPLANTED DEVICES OR SYSTEMS WITH PRODUCT FUNCTIONAL SAFETY REQUIREMENTS; (B) AERONAUTIC APPLICATIONS; (C) AUTOMOTIVE APPLICATIONS OR ENVIRONMENTS, AND/OR (D) AEROSPACE APPLICATIONS OR ENVIRONMENTS. WHERE ST PRODUCTS ARE NOT DESIGNED FOR SUCH USE, THE PURCHASER SHALL USE PRODUCTS AT PURCHASER'S SOLE RISK, EVEN IF ST HAS BEEN INFORMED IN WRITING OF SUCH USAGE, UNLESS A PRODUCT IS EXPRESSLY DESIGNATED BY ST AS BEING INTENDED FOR "AUTOMOTIVE, AUTOMOTIVE SAFETY OR MEDICAL" INDUSTRY DOMAINS ACCORDING TO ST PRODUCT DESIGN SPECIFICATIONS. PRODUCTS FORMALLY ESCC, QML OR JAN QUALIFIED ARE DEEMED SUITABLE FOR USE IN AEROSPACE BY THE CORRESPONDING GOVERNMENTAL AGENCY.**

Resale of ST products with provisions different from the statements and/or technical features set forth in this document shall immediately void any warranty granted by ST for the ST product or service described herein and shall not create or extend in any manner whatsoever, any liability of ST.

ST and the ST logo are trademarks or registered trademarks of ST in various countries.

Information in this document supersedes and replaces all information previously supplied.

The ST logo is a registered trademark of STMicroelectronics. All other names are the property of their respective owners.

© 2013 STMicroelectronics - All rights reserved

STMicroelectronics group of companies

Australia - Belgium - Brazil - Canada - China - Czech Republic - Finland - France - Germany - Hong Kong - India - Israel - Italy - Japan - Malaysia - Malta - Morocco - Philippines - Singapore - Spain - Sweden - Switzerland - United Kingdom - United States of America

[www.st.com](http://www.st.com)