



Chipsmall Limited consists of a professional team with an average of over 10 year of expertise in the distribution of electronic components. Based in Hongkong, we have already established firm and mutual-benefit business relationships with customers from,Europe,America and south Asia,supplying obsolete and hard-to-find components to meet their specific needs.

With the principle of “Quality Parts,Customers Priority,Honest Operation,and Considerate Service”,our business mainly focus on the distribution of electronic components. Line cards we deal with include Microchip,ALPS,ROHM,Xilinx,Pulse,ON,Everlight and Freescale. Main products comprise IC,Modules,Potentiometer,IC Socket,Relay,Connector.Our parts cover such applications as commercial,industrial, and automotives areas.

We are looking forward to setting up business relationship with you and hope to provide you with the best service and solution. Let us make a better world for our industry!



Contact us

Tel: +86-755-8981 8866 Fax: +86-755-8427 6832

Email & Skype: info@chipsmall.com Web: www.chipsmall.com

Address: A1208, Overseas Decoration Building, #122 Zhenhua RD., Futian, Shenzhen, China



PROTECTION PRODUCTS

Description

The SMDAxx series of TVS arrays are designed to provide unidirectional protection for sensitive electronics from damage or latch-up due to ESD, lightning, and other voltage-induced transient events. Each device will protect four data or I/O lines. They are available with operating voltages of 5V, 12V, 15V and 24V.

TVS diodes are solid-state devices designed specifically for transient suppression. They offer desirable characteristics for board level protection including fast response time, low operating and clamping voltage and no device degradation. The low profile SO-8 package allows the user to protect up to four independent lines with one package. The SMDAxx series is suitable protection for sensitive semiconductor components such as microprocessors, ASICs, transceivers, transducers, and CMOS memory.

The SMDAxx series devices may be used to meet the ESD immunity requirements of IEC 61000-4-2, level 4 for air and contact discharge.

Features

- ◆ Transient protection for data lines to
IEC 61000-4-2 (ESD) $\pm 15\text{kV}$ (air), $\pm 8\text{kV}$ (contact)
IEC 61000-4-4 (EFT) 40A (5/50ns)
IEC 61000-4-5 (Lightning) 12A (8/20 μs)
- ◆ Unidirectional protection
- ◆ Small SO-8 package
- ◆ Protects four I/O lines
- ◆ Working voltages: 5V, 12V, 15V and 24V
- ◆ Low leakage current
- ◆ Low operating and clamping voltages
- ◆ Solid-state silicon avalanche technology

Mechanical Characteristics

- ◆ JEDEC SO-8 package
- ◆ Molding compound flammability rating: UL 94V-0
- ◆ Marking : Part number, date code, logo
- ◆ Packaging : Tube or Tape and Reel per EIA 481

Applications

- ◆ RS-232 data lines
- ◆ Microprocessor based equipment
- ◆ Notebooks, Desktops, and Servers
- ◆ Instrumentation
- ◆ LAN/WAN equipment
- ◆ Peripherals
- ◆ Serial and Parallel Ports

Schematic & PIN Configuration

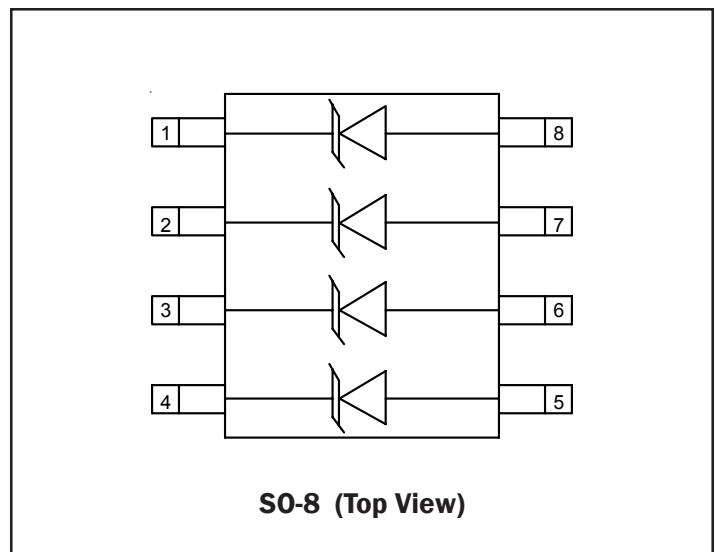

PROTECTION PRODUCTS

Absolute Maximum Rating

Rating	Symbol	Value	Units
Peak Pulse Power ($t_p = 8/20\mu s$)	P_{pk}	300	Watts
ESD Voltage (HBM per IEC 61000-4-2)	V_{ESD}	>25	kV
Lead Soldering Temperature	T_L	260 (10 sec.)	°C
Operating Temperature	T_J	-55 to +125	°C
Storage Temperature	T_{STG}	-55 to +150	°C

Electrical Characteristics (T=25°C)

SMDA05						
Parameter	Symbol	Conditions	Minimum	Typical	Maximum	Units
Reverse Stand-Off Voltage	V_{RWM}				5	V
Reverse Breakdown Voltage	V_{BR}	$I_t = 1mA$	6			V
Reverse Leakage Current	I_R	$V_{RWM} = 5V, T=25^\circ C$			20	μA
Clamping Voltage	V_C	$I_{PP} = 1A, t_p = 8/20\mu s$			9.8	V
Clamping Voltage	V_C	$I_{PP} = 5A, t_p = 8/20\mu s$			11	V
Peak Pulse Current	I_{PP}	$t_p = 8/20\mu s$			17	A
Junction Capacitance	C_j	$V_R = 0V, f = 1MHz$			400	pF

SMDA12						
Parameter	Symbol	Conditions	Minimum	Typical	Maximum	Units
Reverse Stand-Off Voltage	V_{RWM}				12	V
Reverse Breakdown Voltage	V_{BR}	$I_t = 1mA$	13.3			V
Reverse Leakage Current	I_R	$V_{RWM} = 12V, T=25^\circ C$			1	μA
Clamping Voltage	V_C	$I_{PP} = 1A, t_p = 8/20\mu s$			19	V
Clamping Voltage	V_C	$I_{PP} = 5A, t_p = 8/20\mu s$			24	V
Peak Pulse Current	I_{PP}	$t_p = 8/20\mu s$			12	A
Junction Capacitance	C_j	$V_R = 0V, f = 1MHz$			150	pF

PROTECTION PRODUCTS

Electrical Characteristics (Continued)

SMDA15						
Parameter	Symbol	Conditions	Minimum	Typical	Maximum	Units
Reverse Stand-Off Voltage	V_{RWM}				15	V
Reverse Breakdown Voltage	V_{BR}	$I_t = 1mA$	16.7			V
Reverse Leakage Current	I_R	$V_{RWM} = 15V, T=25^{\circ}C$			1	μA
Clamping Voltage	V_C	$I_{PP} = 1A, t_p = 8/20\mu s$			24	V
Clamping Voltage	V_C	$I_{PP} = 5A, t_p = 8/20\mu s$			30	V
Peak Pulse Current	I_{PP}	$t_p = 8/20\mu s$			10	A
Junction Capacitance	C_J	$V_R = 0V, f = 1MHz$			100	pF

SMDA24						
Parameter	Symbol	Conditions	Minimum	Typical	Maximum	Units
Reverse Stand-Off Voltage	V_{RWM}				24	V
Reverse Breakdown Voltage	V_{BR}	$I_t = 1mA$	26.7			V
Reverse Leakage Current	I_R	$V_{RWM} = 24V, T=25^{\circ}C$			1	μA
Clamping Voltage	V_C	$I_{PP} = 1A, t_p = 8/20\mu s$			43	V
Clamping Voltage	V_C	$I_{PP} = 5A, t_p = 8/20\mu s$			55	V
Peak Pulse Current	I_{PP}	$t_p = 8/20\mu s$			5	A
Junction Capacitance	C_J	$V_R = 0V, f = 1MHz$			60	pF

PROTECTION PRODUCTS

Typical Characteristics

Non-Repetitive Peak Pulse Power vs. Pulse Time

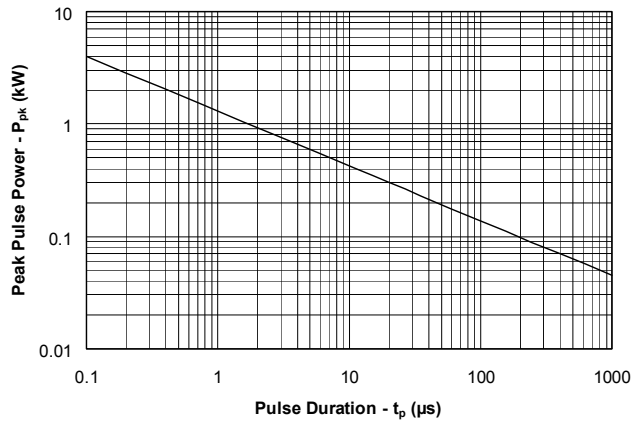

Power Derating Curve

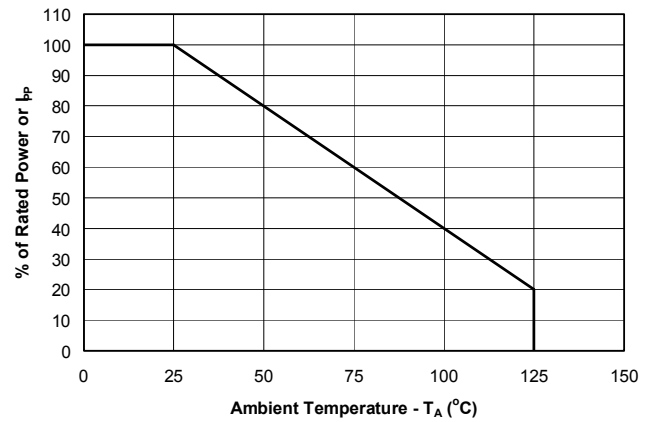

Pulse Waveform

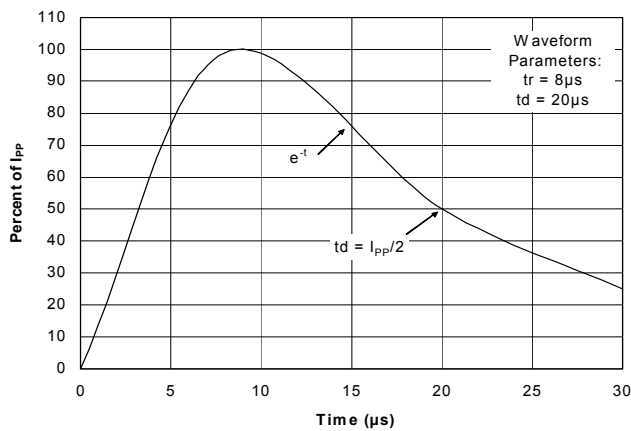

ESD Pulse Waveform (IEC 61000-4-2)

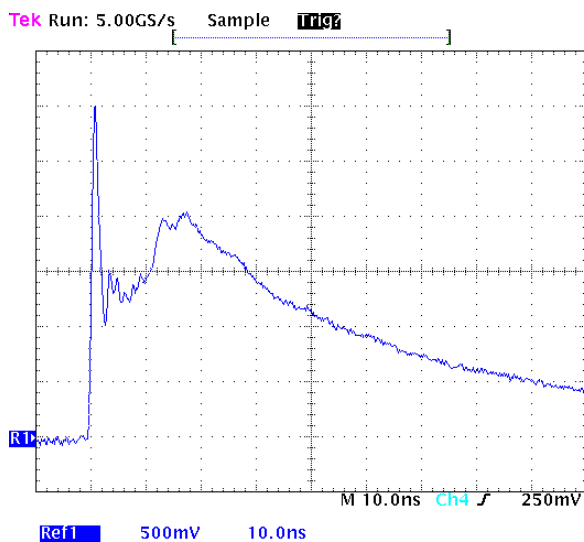

IEC 61000-4-2 Discharge Parameters

Level	First Peak Current (A)	Peak Current at 30 ns (A)	Peak Current at 60 ns (A)	Test Voltage (Contact Discharge) (kV)	Test Voltage (Air Discharge) (kV)
1	7.5	4	8	2	2
2	15	8	4	4	4
3	22.5	12	6	6	8
4	30	16	8	8	15

PROTECTION PRODUCTS

Applications Information

Device Connection for Protection of Four Data Lines

The SMDAxx series of devices are designed to protect up to four data lines. The devices are connected as follows:

- The SMDAxx are unidirectional devices and are designed for use on lines where the normal operating voltage is above ground. Pins 1, 2, 3, and 4 are connected to the protected lines. Pins 5, 6, 7, and 8 are connected to ground. The ground connections should be made directly to the ground plane for best results. The path length is kept as short as possible to reduce the effects of parasitic inductance in the board traces.

Circuit Board Layout Recommendations for Suppression of ESD.

Good circuit board layout is critical for the suppression of ESD induced transients. The following guidelines are recommended:

- Place the TVS near the input terminals or connectors to restrict transient coupling.
- Minimize the path length between the TVS and the protected line.
- Minimize all conductive loops including power and ground loops.
- The ESD transient return path to ground should be kept as short as possible.
- Never run critical signals near board edges.
- Use ground planes whenever possible.

Matte Tin Lead Finish

Matte tin has become the industry standard lead-free replacement for SnPb lead finishes. A matte tin finish is composed of 100% tin solder with large grains. Since the solder volume on the leads is small compared to the solder paste volume that is placed on the land pattern of the PCB, the reflow profile will be determined by the requirements of the solder paste. Therefore, these devices are compatible with both lead-free and SnPb assembly techniques. In addition, unlike other lead-free compositions, matte tin does not have any added alloys that can cause degradation of the solder joint.

Circuit Diagram

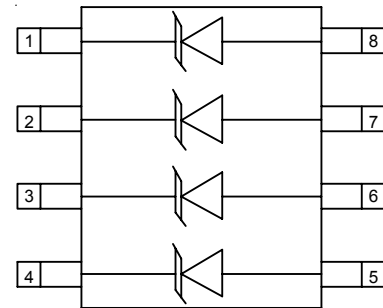

I/O Line Protection

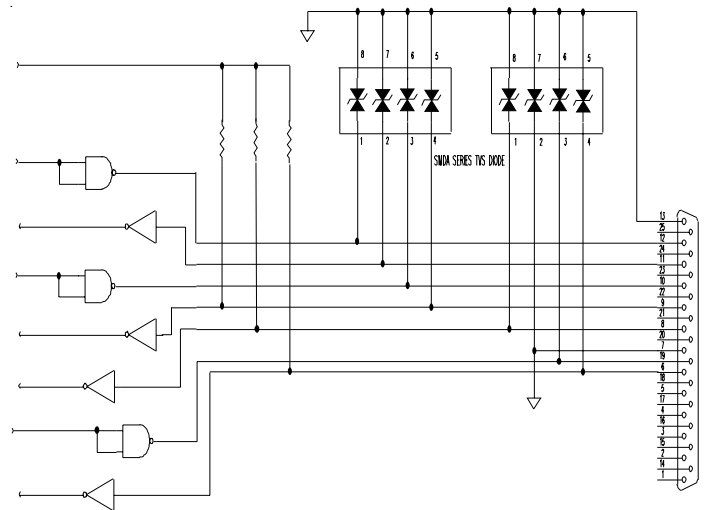

Typical Connection

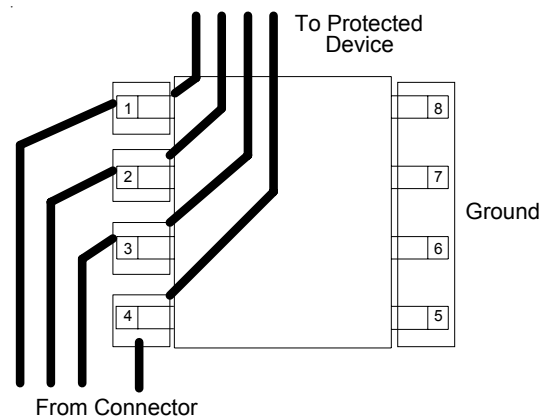

PROTECTION PRODUCTS

Outline Drawing - SO-8

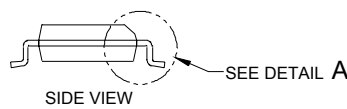
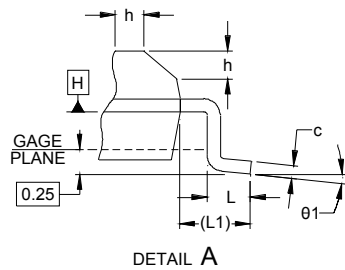
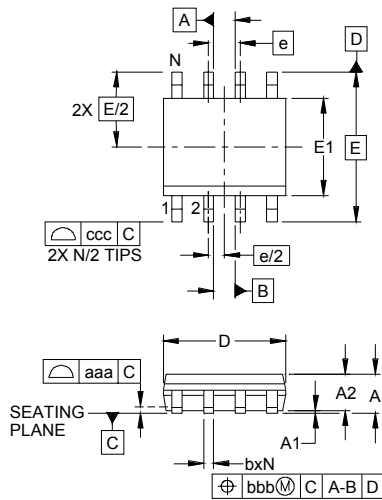

DIM	INCHES		MILLIMETERS	
	MIN	NOM	MIN	MAX
A	.053	-	.069	1.35 - 1.75
A1	.004	-	.010	- 0.25
A2	.049	-	.065	1.25 - 1.65
b	.012	-	.020	0.31 - 0.51
c	.007	-	.010	0.17 - 0.25
D	.189	.193	.197	4.80 4.90 5.00
E1	.150	.154	.157	3.80 3.90 4.00
E	.236 BSC		6.00 BSC	
e	.050 BSC		1.27 BSC	
h	.010	-	.020	0.25 - 0.50
L	.016	.028	.041	0.40 0.72 1.04
L1	(0.041)		(1.04)	
N	8		8	
theta 1	0°	-	8°	0° - 8°
aaa	.004		0.10	
bbb	.010		0.25	
ccc	.008		0.20	

NOTES:

1. CONTROLLING DIMENSIONS ARE IN MILLIMETERS (ANGLES IN DEGREES).
2. DATUMS **-A-** AND **-B-** TO BE DETERMINED AT DATUM PLANE **-H-**.
3. DIMENSIONS "E1" AND "D" DO NOT INCLUDE MOLD FLASH, PROTRUSIONS OR GATE BURRS.
4. REFERENCE JEDEC STD MS-012, VARIATION AA.

Land Pattern - SO-8

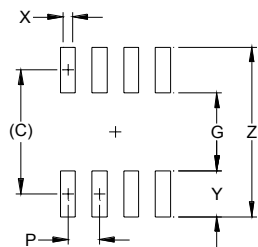

DIM	DIMENSIONS	
	INCHES	MILLIMETERS
C	(.205)	(5.20)
G	.118	3.00
P	.050	1.27
X	.024	0.60
Y	.087	2.20
Z	.291	7.40

NOTES:

1. THIS LAND PATTERN IS FOR REFERENCE PURPOSES ONLY. CONSULT YOUR MANUFACTURING GROUP TO ENSURE YOUR COMPANY'S MANUFACTURING GUIDELINES ARE MET.
2. REFERENCE IPC-SM-782A, RLP NO. 300A.

PROTECTION PRODUCTS

Ordering Information

Part Number	Working Voltage	Lead Finish	Qty per Reel	Reel Size
SMDA05.TB	5	SnPb	500	7 Inch
SMDA12.TB	12	SnPb	500	7 Inch
SMDA15.TB	15	SnPb	500	7 Inch
SMDA24.TB	24	SnPb	500	7 Inch
SMDA05.TBT	5	Pb Free	500	7 Inch
SMDA12.TBT	12	Pb Free	500	7 Inch
SMDA15.TBT	15	Pb Free	500	7 Inch
SMDA24.TBT	24	Pb Free	500	7 Inch
SMDA05	5	SnPb	95/Tube	N/A
SMDA12	12	SnPb	95/Tube	N/A
SMDA15	15	SnPb	95/Tube	N/A
SMDA24	24	SnPb	95/Tube	N/A
SMDA05.T	5	Pb Free	95/Tube	N/A
SMDA12.T	12	Pb Free	95/Tube	N/A
SMDA15.T	15	Pb Free	95/Tube	N/A
SMDA24.T	24	Pb Free	95/Tube	N/A

Note: Lead-free devices are RoHS/WEEE Compliant

Contact Information

Semtech Corporation
 Protection Products Division
 200 Flynn Road, Camarillo, CA 93012
 Phone: (805)498-2111 FAX (805)498-3804