



Chipsmall Limited consists of a professional team with an average of over 10 year of expertise in the distribution of electronic components. Based in Hongkong, we have already established firm and mutual-benefit business relationships with customers from,Europe,America and south Asia,supplying obsolete and hard-to-find components to meet their specific needs.

With the principle of "Quality Parts,Customers Priority,Honest Operation,and Considerate Service",our business mainly focus on the distribution of electronic components. Line cards we deal with include Microchip,ALPS,ROHM,Xilinx,Pulse,ON,Everlight and Freescale. Main products comprise IC,Modules,Potentiometer,IC Socket,Relay,Connector.Our parts cover such applications as commercial,industrial, and automotives areas.

We are looking forward to setting up business relationship with you and hope to provide you with the best service and solution. Let us make a better world for our industry!



Contact us

Tel: +86-755-8981 8866 Fax: +86-755-8427 6832

Email & Skype: info@chipsmall.com Web: www.chipsmall.com

Address: A1208, Overseas Decoration Building, #122 Zhenhua RD., Futian, Shenzhen, China



PROTECTION PRODUCTS

Description

The SMDAxxCN-5 series of transient voltage suppressors are designed to protect components which are connected to data and transmission lines from voltage surges caused by electrostatic discharge (ESD), electrical fast transients (EFT), and lightning.

TVS diodes are characterized by their high surge capability, low operating and clamping voltages, and fast response time. This makes them ideal for use as board level protection of sensitive semiconductor components. The SMDAxxCN-5 is designed to provide transient suppression on multiple data lines and I/O ports. The low profile SO-8 design allows the user to protect up to five data and I/O lines with one package.

The SMDAxxCN-5 TVS diode array will meet the surge requirements of IEC 61000-4-2 (Formerly IEC 801-2), Level 4, "Human Body Model" for air and contact discharge.

Features

- ◆ 300 watts peak pulse power ($t_p = 8/20\mu s$)
- ◆ Transient protection for data lines to
IEC 61000-4-2 (ESD) $\pm 15kV$ (air), $\pm 8kV$ (contact)
IEC 61000-4-4 (EFT) 40A (5/50ns)
IEC 61000-4-5 (Lightning) 12A (8/20 μs)
- ◆ Protects up to 5 bidirectional lines
- ◆ Low operating voltage
- ◆ Low clamping voltage
- ◆ Solid-state silicon avalanche technology

Mechanical Characteristics

- ◆ JEDEC SO-8 package
- ◆ Molding compound flammability rating: UL 94V-0
- ◆ Marking : Part number, date code, logo
- ◆ Packaging : Tube or Tape and Reel per EIA 481

Applications

- ◆ RS-232 Data Lines
- ◆ RS-423 Data Lines
- ◆ LAN/WAN Equipment
- ◆ Servers
- ◆ Notebook and Desktop PC
- ◆ Set Top Box
- ◆ Peripherals

Circuit Diagram

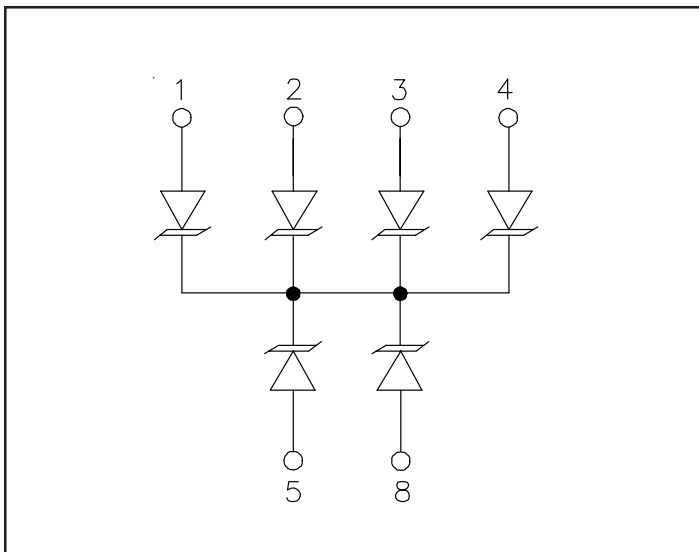

Schematic and PIN Configuration

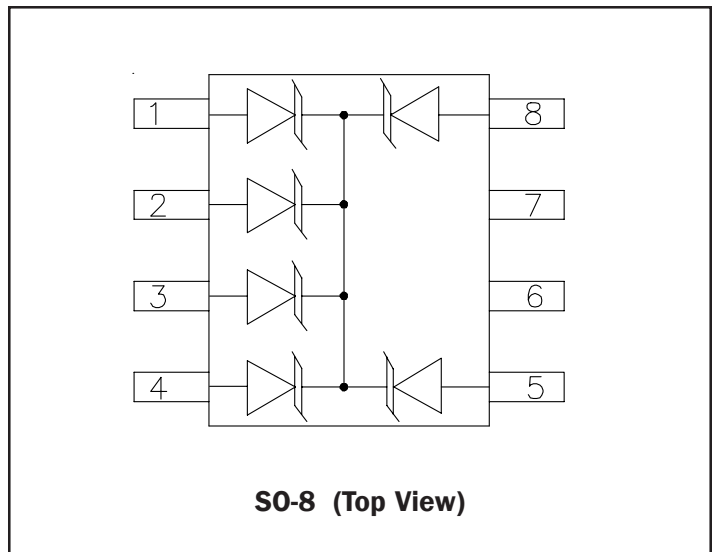

PROTECTION PRODUCTS

Absolute Maximum Rating

Rating	Symbol	Value	Units
Peak Pulse Power (tp = 8/20μs)	P _{pk}	300	Watts
Peak Pulse Current (tp = 8/20μs)	I _{pp}	20	A
Lead Soldering Temperature	T _L	260 (10 sec.)	°C
Operating Temperature	T _J	-55 to +125	°C
Storage Temperature	T _{STG}	-55 to +150	°C

Electrical Characteristics (T=25°C)

SMDA05CN-5						
Parameter	Symbol	Conditions	Minimum	Typical	Maximum	Units
Reverse Stand-Off Voltage	V _{RWM}				5	V
Reverse Breakdown Voltage	V _{BR}	I _t = 1mA	6			V
Reverse Leakage Current	I _R	V _{RWM} = 5V, T=25°C			10	μA
Clamping Voltage	V _C	I _{pp} = 1A, tp = 8/20μs			9.8	V
Clamping Voltage	V _C	I _{pp} = 10A, tp = 8/20μs			11	V
Maximum Peak Pulse Current	I _{pp}	tp = 8/20μs			20	A
Junction Capacitance	C _J	Between I/O Pins and Ground V _R = 0V, f = 1MHz			350	pF
SMDA15CN-5						
Parameter	Symbol	Conditions	Minimum	Typical	Maximum	Units
Reverse Stand-Off Voltage	V _{RWM}				15	V
Reverse Breakdown Voltage	V _{BR}	I _t = 1mA	16.7			V
Reverse Leakage Current	I _R	V _{RWM} = 15V, T=25°C			1	μA
Clamping Voltage	V _C	I _{pp} = 1A, tp = 8/20μs			24	V
Clamping Voltage	V _C	I _{pp} = 10A, tp = 8/20μs			30	V
Maximum Peak Pulse Current	I _{pp}	tp = 8/20μs			10	A
Junction Capacitance	C _J	Between I/O Pins and Ground V _R = 0V, f = 1MHz			75	pF

PROTECTION PRODUCTS

Typical Characteristics

Non-Repetitive Peak Pulse Power vs. Pulse Time

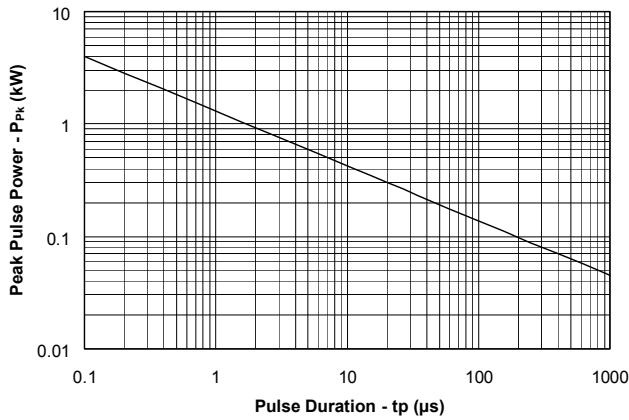

Power Derating Curve

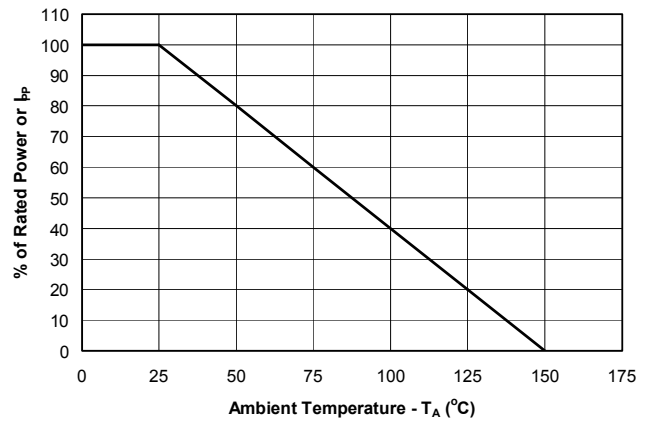

Pulse Waveform

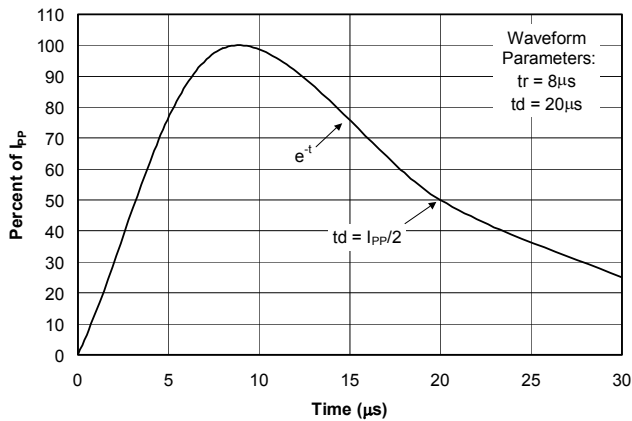

Clamping Voltage vs. Peak Pulse Current

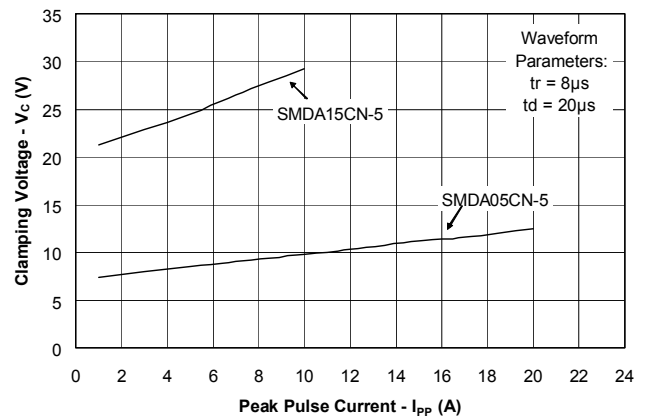

PROTECTION PRODUCTS

Applications Information

Device Connection Options for Protection of Four or Five Data Lines

The SMDAxxCN-5 can be configured to protect either four or five bidirectional data lines. The options for connecting the devices are as follows:

1. Bidirectional protection of four I/O lines is achieved by connecting pins 1, 2, 3, and 4 to the data lines. Pins 5, 6, 7, and 8 are connected to ground. The ground connection should be made directly to the ground plane for best results. The path length is kept as short as possible to reduce the effects of parasitic inductance in the board traces. In this configuration, the device can withstand the maximum specified transient impulse on four lines simultaneously.
2. Bidirectional protection of five I/O lines is achieved by connecting pins 1, 2, 3, 4, and 5 to the data lines. Pins 6, 7, and 8 are connected to ground. The ground connection should be made directly to the circuit board ground plane for best results. In this configuration, the device can withstand the maximum rated transient impulse on any two lines simultaneously.

Circuit Board Layout Recommendations for Suppression of ESD.

Good circuit board layout is critical for the suppression of ESD induced transients. The following guidelines are recommended:

- Place the TVS near the input terminals or connectors to restrict transient coupling.
- Minimize the path length between the TVS and the protected line.
- Minimize all conductive loops including power and ground loops.
- The ESD transient return path to ground should be kept as short as possible.
- Never run critical signals near board edges.
- Use ground planes whenever possible.

Protection for Four Bidirectional Lines

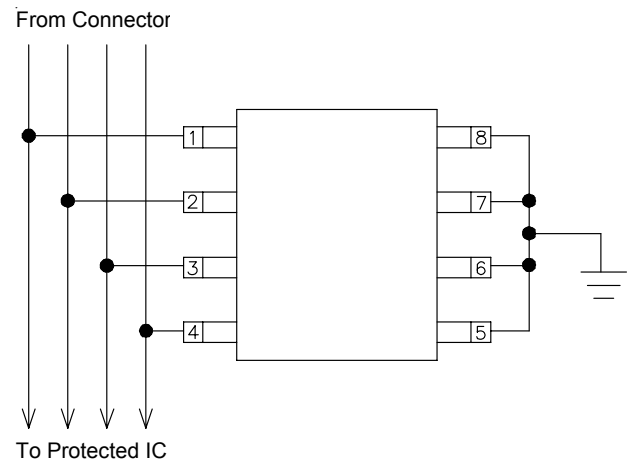

Protection for Five Bidirectional Lines

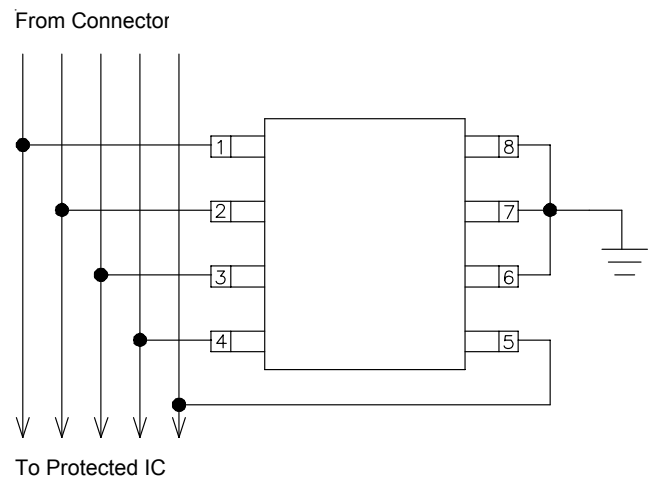

Matte Tin Lead Finish

Matte tin has become the industry standard lead-free replacement for SnPb lead finishes. A matte tin finish is composed of 100% tin solder with large grains. Since the solder volume on the leads is small compared to the solder paste volume that is placed on the land pattern of the PCB, the reflow profile will be determined by the requirements of the solder paste. Therefore, these devices are compatible with both lead-free and SnPb assembly techniques. In addition, unlike other lead-free compositions, matte tin does not have any added alloys that can cause degradation of the solder joint.

PROTECTION PRODUCTS

Outline Drawing - S0-8

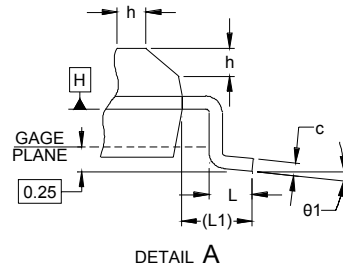
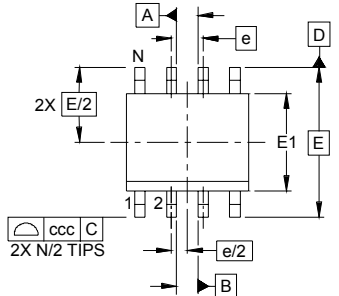

DIM	DIMENSIONS					
	INCHES			MILLIMETERS		
	MIN	NOM	MAX	MIN	NOM	MAX
A	.053	-	.069	1.35	-	1.75
A1	.004	-	.010	0.10	-	0.25
A2	.049	-	.065	1.25	-	1.65
b	.012	-	.020	0.31	-	0.51
c	.007	-	.010	0.17	-	0.25
D	.189	.193	.197	4.80	4.90	5.00
E1	.150	.154	.157	3.80	3.90	4.00
E	.236 BSC			6.00 BSC		
e	.050 BSC			1.27 BSC		
h	.010	-	.020	0.25	-	0.50
L	.016	.028	.041	0.40	0.72	1.04
L1	(0.041)			(1.04)		
N	8			8		
theta1	0°	-	8°	0°	-	8°
aaa	.004			0.10		
bbb	.010			0.25		
ccc	.008			0.20		

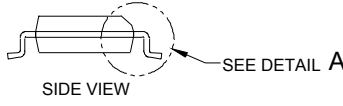
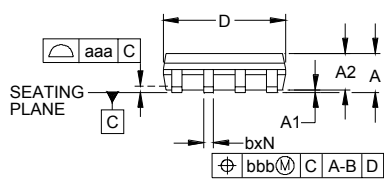

- NOTES:
1. CONTROLLING DIMENSIONS ARE IN MILLIMETERS (ANGLES IN DEGREES).
 2. DATUMS **-A-** AND **-B-** TO BE DETERMINED AT DATUM PLANE **-H-**
 3. DIMENSIONS "E1" AND "D" DO NOT INCLUDE MOLD FLASH, PROTRUSIONS OR GATE BURRS.
 4. REFERENCE JEDEC STD MS-012, VARIATION AA.

Land Pattern - S0-8

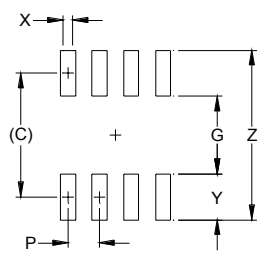

DIM	DIMENSIONS	
	INCHES	MILLIMETERS
C	(.205)	(5.20)
G	.118	3.00
P	.050	1.27
X	.024	0.60
Y	.087	2.20
Z	.291	7.40

- NOTES:
1. THIS LAND PATTERN IS FOR REFERENCE PURPOSES ONLY. CONSULT YOUR MANUFACTURING GROUP TO ENSURE YOUR COMPANY'S MANUFACTURING GUIDELINES ARE MET.
 2. REFERENCE IPC-SM-782A, RLP NO. 300A.

PROTECTION PRODUCTS**Ordering Information**

Part Number	Lead Finish	Qty per Reel	Reel Size
SMDA05CN-5.TB	SnPb	500	7 Inch
SMDA15CN-5.TB	SnPb	500	7 Inch
SMDA05CN-5.TBT	Pb Free	500	7 Inch
SMDA15CN-5.TBT	Pb Free	500	7 Inch
SMDA05CN-5	SnPb	95/Tube	N/A
SMDA15CN-5	SnPb	95/Tube	N/A
SMDA05CN-5.T	Pb Free	95/Tube	N/A
SMDA15CN-5.T	Pb Free	95/Tube	N/A

Note: Lead-free devices are RoHS/WEEE Compliant

Contact Information

Semtech Corporation
Protection Products Division
200 Flynn Road, Camarillo, CA 93012
Phone: (805)498-2111 FAX (805)498-3804