



Chipsmall Limited consists of a professional team with an average of over 10 year of expertise in the distribution of electronic components. Based in Hongkong, we have already established firm and mutual-benefit business relationships with customers from,Europe,America and south Asia,supplying obsolete and hard-to-find components to meet their specific needs.

With the principle of “Quality Parts,Customers Priority,Honest Operation,and Considerate Service”,our business mainly focus on the distribution of electronic components. Line cards we deal with include Microchip,ALPS,ROHM,Xilinx,Pulse,ON,Everlight and Freescale. Main products comprise IC,Modules,Potentiometer,IC Socket,Relay,Connector.Our parts cover such applications as commercial,industrial, and automotives areas.

We are looking forward to setting up business relationship with you and hope to provide you with the best service and solution. Let us make a better world for our industry!



Contact us

Tel: +86-755-8981 8866 Fax: +86-755-8427 6832

Email & Skype: info@chipsmall.com Web: www.chipsmall.com

Address: A1208, Overseas Decoration Building, #122 Zhenhua RD., Futian, Shenzhen, China



Chip LEDs with reflectors

SML-010 Series

The SML-010 series are high luminance chip LEDs with reflectors. The compact and leadless design of these LEDs allows for high mounting density.

●Features

- 1) Reflectors are used to achieve a high luminance.
- 2) Four colors : red, orange, yellow and green.
- 3) Rectangular and leadless (3x2mm)
- 4) Can be mounted by automatic mounting.

●External dimensions (Units : mm)

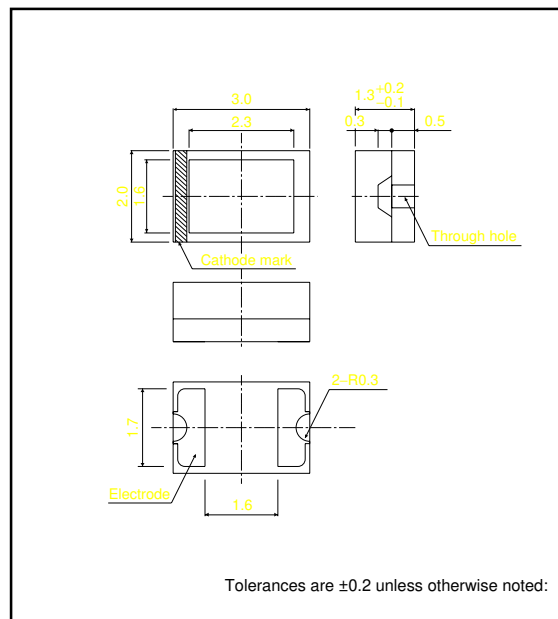

●Selection guide

| Emitting color Lens | Red | Orange | Yellow | Green |
|------------------------|-------------------|-----------|-----------|-----------|
| | Transparent clear | SML-010LT | SML-010DT | SML-010YT |
| | SML-010VT | — | — | SML-010FT |
| | — | — | — | SML-010PT |

●Absolute maximum ratings (Ta=25°C)

| Parameter | Symbol | Limits | | Unit |
|-----------------------|------------------|----------------|--------------|------|
| | | Bright red (L) | Other colors | |
| Power dissipation | P _D | 75 | 70 | mW |
| Forward current | I _F | 30 | 25 | mA |
| Peak forward current | I _{FP} | 75 | 60 | mA* |
| Reverse voltage | V _R | 4 | | V |
| Operating temperature | T _{opr} | -30~+85 | | °C |
| Storage temperature | T _{stg} | -40~+85 | | °C |

* Pulse width 1ms Duty 1 / 5

LED lamps

●Electrical and optical characteristics (Ta=25°C)

| Parameter Type | Color | Forward voltage | | | Reverse current | | | Luminous intensity | | | Peak wavelength | | Spectral line half width | |
|-------------------|-------|--------------------|------|---------------------|---------------------|--------------------|----------------------|--------------------|---------------------|-------|---------------------|-------|--------------------------|----|
| | | V _F (V) | | Cond. | I _R (μA) | Cond. | I _v (mcd) | | λ _P (nm) | Cond. | Δλ (nm) | Cond. | | |
| | | Typ. | Max. | I _F (mA) | Max. | V _R (V) | Min. | Typ. | I _F (mA) | Typ. | I _F (mA) | Typ. | I _F (mA) | |
| SML-010 | LT | Red | 1.75 | 2.5 | 20 | 100 | 4 | 5.6 | 16.0 | 20 | 660 | 20 | 25 | 20 |
| | VT | Red | 2.0 | 2.8 | 20 | 100 | 4 | 2.2 | 6.3 | 20 | 650 | 20 | 40 | 20 |
| | DT | Orange | 2.0 | 2.8 | 20 | 100 | 4 | 3.6 | 10.0 | 20 | 610 | 20 | 40 | 20 |
| | YT | Yellow | 2.1 | 2.8 | 20 | 100 | 4 | 2.2 | 6.3 | 20 | 585 | 20 | 40 | 20 |
| | MT | Green | 2.2 | 2.8 | 20 | 100 | 4 | 5.6 | 25.0 | 20 | 570 | 20 | 40 | 20 |
| | FT | Green | 2.2 | 2.8 | 20 | 100 | 4 | 3.6 | 10.0 | 20 | 560 | 20 | 40 | 20 |
| | PT | Green | 2.2 | 2.8 | 20 | 100 | 4 | 2.2 | 6.3 | 20 | 555 | 20 | 40 | 20 |

●Directional pattern

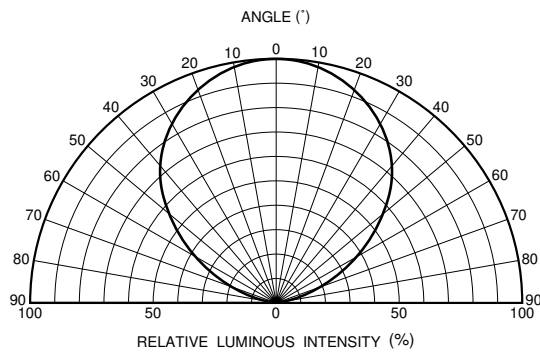

Fig.1 Directional pattern

●Electrical characteristics curves 1 (SML-010LT) (bright red)

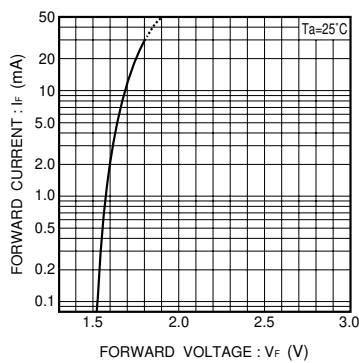

Fig.2 Forward current vs. forward voltage

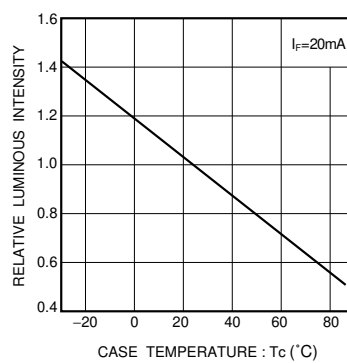

Fig.3 Luminous intensity vs. case temperature

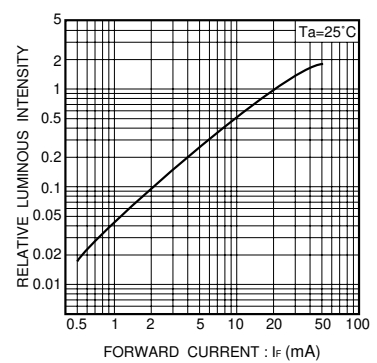

Fig.4 Luminous intensity vs. forward current

LED lamps

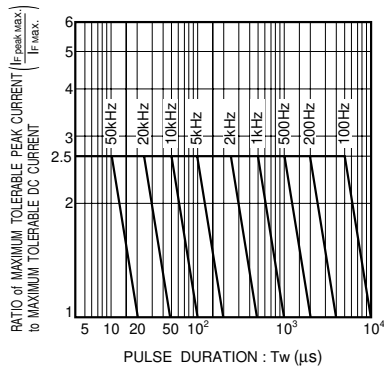

Fig.5 Maximum tolerable peak current vs. pulse duration

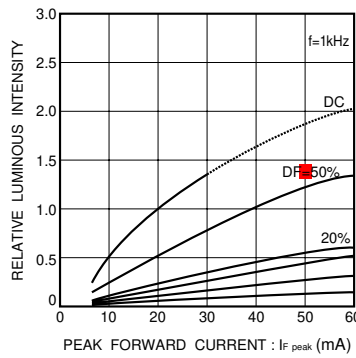

Fig. 6 Luminous intensity vs. peak forward current

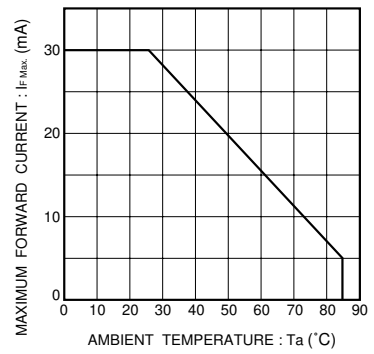

Fig. 7 Maximum forward current vs. ambient temperature (Derating)

●Electrical characteristics curves 2 (SML-010VT) (red)

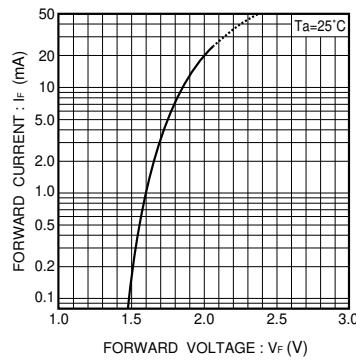

Fig.8 Forward current vs. forward voltage

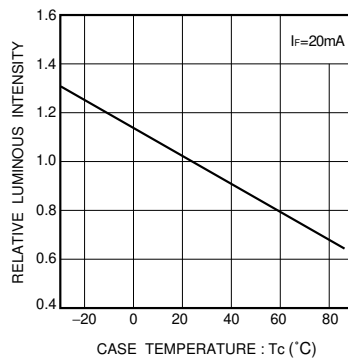

Fig.9 Luminous intensity vs. case temperature

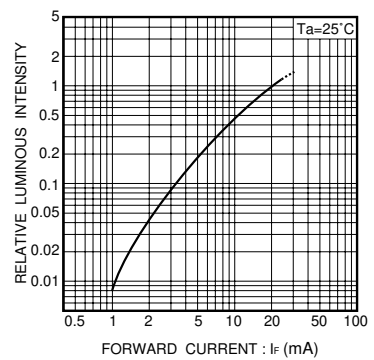

Fig.10 Luminous intensity vs. forward current

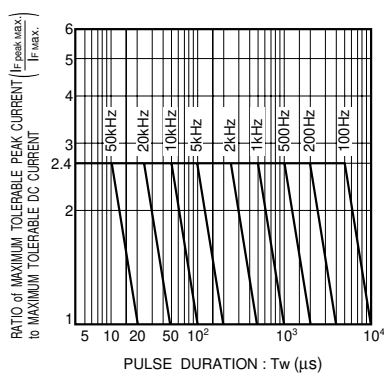

Fig.11 Maximum tolerable peak current vs. pulse duration

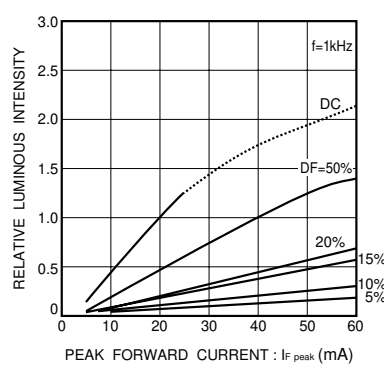

Fig.1 2 Luminous intensity vs. peak forward current

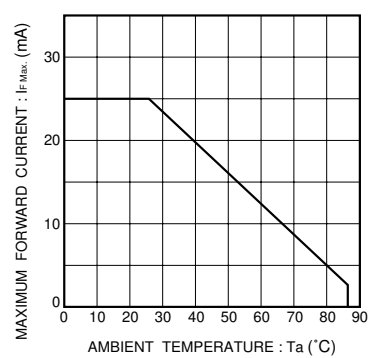

Fig.13 Maximum forward current vs. ambient temperature (Derating)

LED lamps

●Electrical characteristics curves 3 (SML-010DT) (orange)

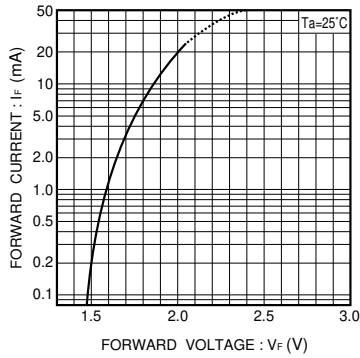

Fig.14 Forward current vs. forward voltage

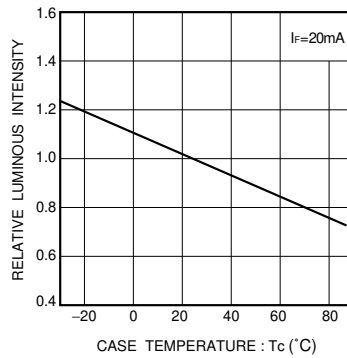

Fig.15 Luminous intensity vs. case temperature

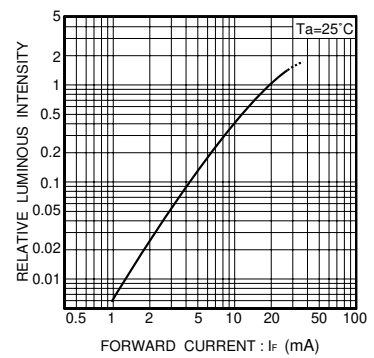

Fig.16 Luminous intensity vs. forward current

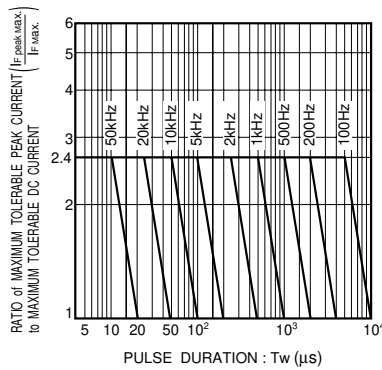

Fig.17 Maximum tolerable peak current vs. pulse duration

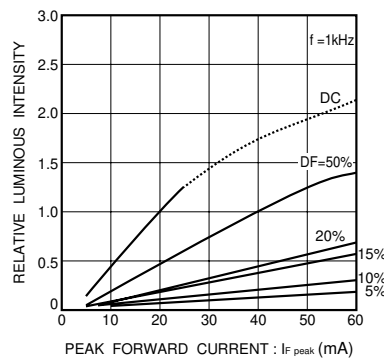

Fig.18 Luminous intensity vs. peak forward current

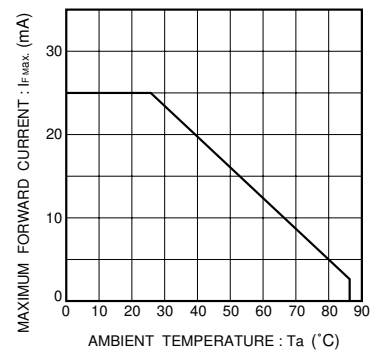

Fig.19 Maximum forward current vs. ambient temperature (Derating)

●Electrical characteristics curves 4 (SML-010YT) (yellow)

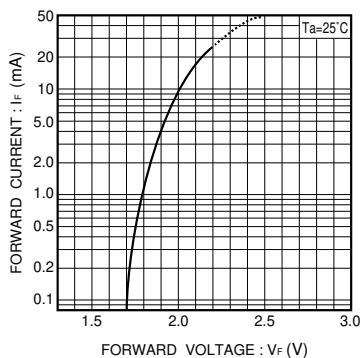

Fig.20 Forward current vs. forward voltage

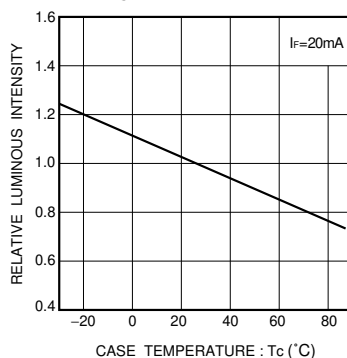

Fig.21 Luminous intensity vs. case temperature

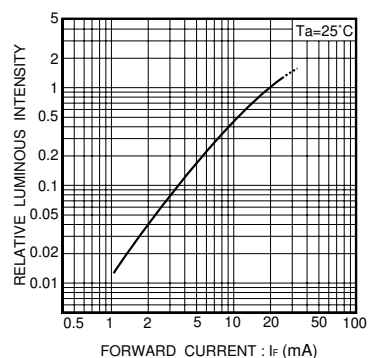

Fig.22 Luminous intensity vs. forward current

LED lamps

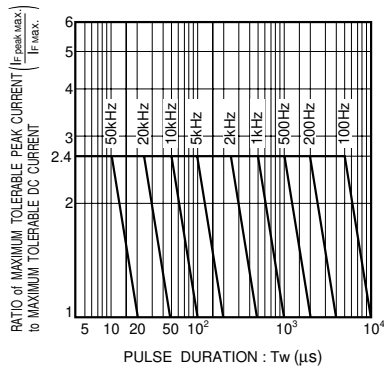

Fig.23 Maximum tolerable peak current vs. pulse duration

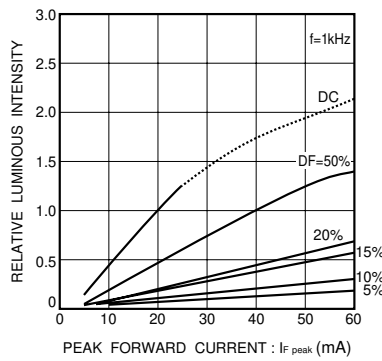

Fig.24 Luminous intensity vs. peak forward current

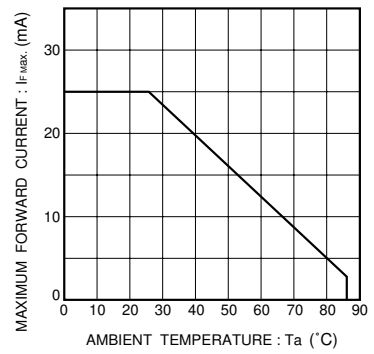

Fig.25 Maximum forward current vs. ambient temperature (Derating)

●Electrical characteristics curves 5 (SML-010MT, SML-010FT, SML-010PT) (green)

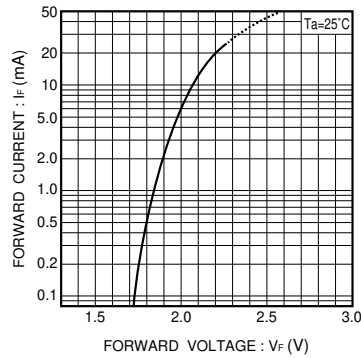

Fig.26 Forward current vs. forward voltage

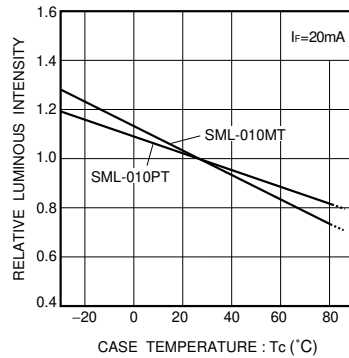

Fig.27 Luminous intensity vs. case temperature

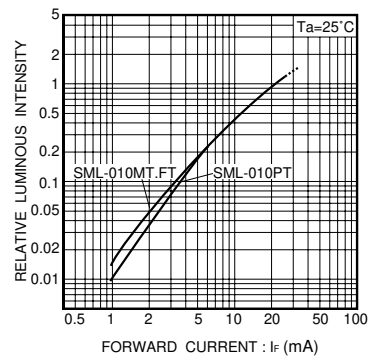

Fig.28 Luminous intensity vs. forward current

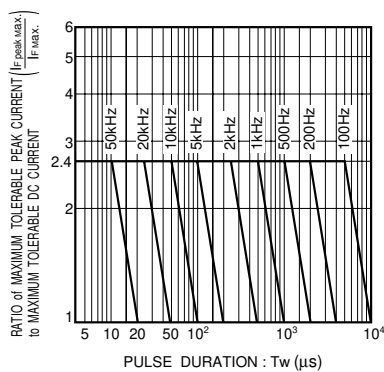

Fig.29 Maximum tolerable peak current vs. pulse duration

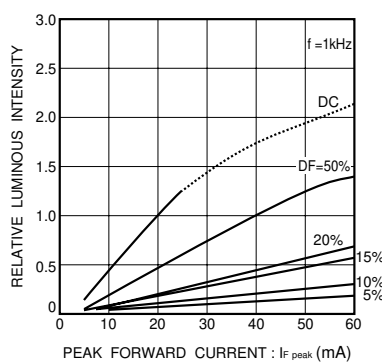

Fig.30 Luminous intensity vs. peak forward current

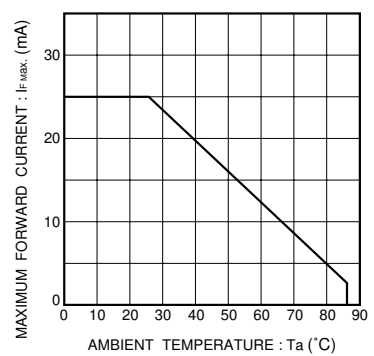

Fig.31 Maximum forward current vs. ambient temperature (Derating)