



Chipsmall Limited consists of a professional team with an average of over 10 year of expertise in the distribution of electronic components. Based in Hongkong, we have already established firm and mutual-benefit business relationships with customers from,Europe,America and south Asia,supplying obsolete and hard-to-find components to meet their specific needs.

With the principle of “Quality Parts,Customers Priority,Honest Operation,and Considerate Service”,our business mainly focus on the distribution of electronic components. Line cards we deal with include Microchip,ALPS,ROHM,Xilinx,Pulse,ON,Everlight and Freescale. Main products comprise IC,Modules,Potentiometer,IC Socket,Relay,Connector.Our parts cover such applications as commercial,industrial, and automotives areas.

We are looking forward to setting up business relationship with you and hope to provide you with the best service and solution. Let us make a better world for our industry!



## Contact us

Tel: +86-755-8981 8866 Fax: +86-755-8427 6832

Email & Skype: info@chipsmall.com Web: www.chipsmall.com

Address: A1208, Overseas Decoration Building, #122 Zhenhua RD., Futian, Shenzhen, China



|             |                                     |      |      |
|-------------|-------------------------------------|------|------|
| PART NUMBER | SSL-LX5093UWC/G                     | REV. | C    |
| DATE        | E.C.N. NUMBER AND REVISION COMMENTS |      | REV. |
| 01.06.06    | E.C.N. #11283.                      |      | A    |
| 10.27.06    | E.C.N. #11148.                      |      | B    |
| 10.10.12    | E.C.N. #10BRDR. & REDRAWN.          |      | C    |

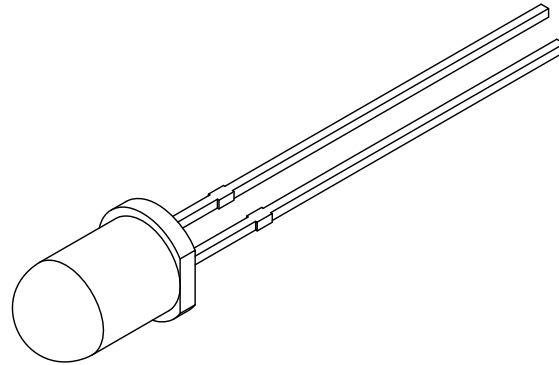
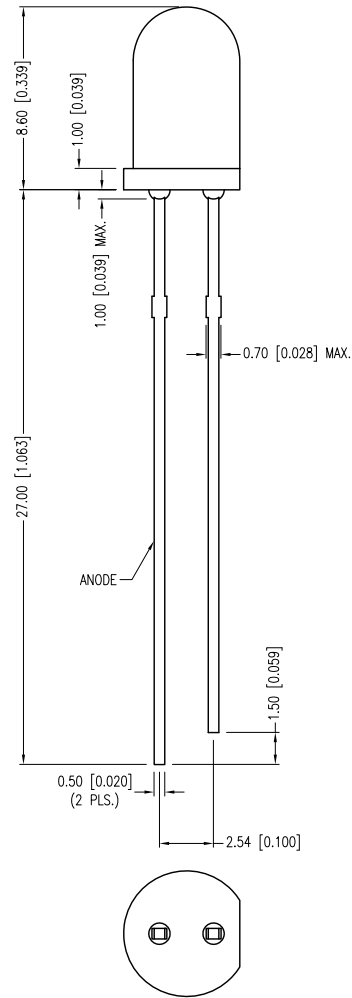
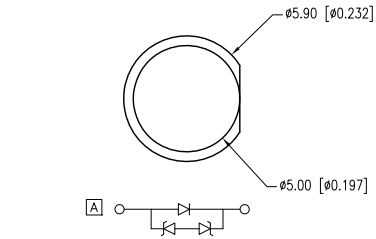

ELECTRO-OPTICAL CHARACTERISTICS Ta=25°C If=20mA

| PARAMETER         | MIN         | TYP  | MAX    | UNITS    | TEST COND |
|-------------------|-------------|------|--------|----------|-----------|
| PEAK WAVELENGTH   |             |      |        | nm       |           |
| FORWARD VOLTAGE   |             | 3.5  | 4.0    | Vf       | If=20mA   |
| REVERSE VOLTAGE   | 5.0         |      |        | Vr       | Ir=10μA   |
| AXIAL INTENSITY*  | 9000        |      | 11,000 | mcd      | If=20mA   |
| CHROMATICITY (X)  |             | 0.29 |        |          |           |
| COORDINATES (Y)** |             | 0.30 |        |          | If=20mA   |
| VIEWING ANGLE     |             | 20   |        | 2x theta |           |
| EMITTED COLOR:    | WHITE       |      |        |          |           |
| LENS FINISH:      | WATER CLEAR |      |        |          |           |

\*AXIAL INTENSITY TESTING CONDITION 550nm WAVELENGTH.  
 \*\*THE ICI STANDARD COLORIMETRIC SYSTEM.

LIMITS OF SAFE OPERATION AT 25°C

| PARAMETER             | SYMBOL | MAX         | UNITS |
|-----------------------|--------|-------------|-------|
| PULSE FORWARD CURRENT | Ip     | 100         | mA    |
| STEADY CURRENT        | If     | 25          | mA    |
| POWER DISSIPATION     | Pd     | 100         | mW    |
| OPERATING TEMP.       | ToPR   | -40 TO +85  | °C    |
| STORAGE TEMP.         | Sstg   | -40 TO +100 | °C    |
| SOLDERING TEMP.       |        | +260        | °C    |
| 2.0mm FROM BODY       |        | 3           | SEC.  |

\*DUTY 1/10 PULSE WIDTH 10ms

CAUTION: STATIC SENSITIVE DEVICE  
 FOLLOW PROPER E.S.D. HANDLING PROCEDURES  
 WHEN WORKING WITH THIS PART.

\*UNLESS OTHERWISE SPECIFIED TOLERANCES PER DECIMAL PRECISION ARE: X=±1 (±0.039), X.X=±0.5 (±0.020), X.XX=±0.25 (±0.010), X.XXX=±0.127 (±0.005). LEAD SIZE=±0.05 (±0.002), LEAD LENGTH=±0.75 (±0.030). MIN= +DECIMAL PRECISION MAX.= +0.00 -DECIMAL PRECISION



425 N. GARY AVE.  
 CAROL STREAM, IL 60188-4900  
 PHONE: +1.800.278.5666  
 FAX: +1.630.315.2152  
 WEB: WWW.LUMEX.COM  
 MEMBER OF ITW PHOTONICS GROUP

QUASARBRITE T-5mm (T-1 3/4) ULTRA WHITE LED, WATER CLEAR LENS.

\*\*THE SPECIFICATIONS MAY CHANGE AT ANY TIME WITHOUT NOTICE DUE TO NEW MATERIALS OR PRODUCT IMPROVEMENT.\*\*

CONFIDENTIAL INFORMATION  
 THE INFORMATION CONTAINED IN THIS DOCUMENT IS THE PROPERTY OF LUMEX INC. EXCEPT AS SPECIFICALLY AUTHORIZED IN WRITING BY LUMEX INC., THE HOLDER OF THIS DOCUMENT SHALL KEEP ALL INFORMATION CONTAINED HEREIN CONFIDENTIAL AND SHALL PROTECT SAME IN WHOLE OR IN PART FROM DISCLOSURE AND DISSEMINATION TO ALL THIRD PARTIES.

|        |           |           |    |
|--------|-----------|-----------|----|
| DATE:  | 10.10.12  | DRAWN BY: | AB |
| PAGE:  | 1 OF 1    | CHKD BY:  | KF |
| SCALE: | NTS       | APRVD BY: | KF |
| UNIT:  | mm [INCH] |           | Ⓟ  |