



Chipsmall Limited consists of a professional team with an average of over 10 year of expertise in the distribution of electronic components. Based in Hongkong, we have already established firm and mutual-benefit business relationships with customers from,Europe,America and south Asia,supplying obsolete and hard-to-find components to meet their specific needs.

With the principle of "Quality Parts,Customers Priority,Honest Operation,and Considerate Service",our business mainly focus on the distribution of electronic components. Line cards we deal with include Microchip,ALPS,ROHM,Xilinx,Pulse,ON,Everlight and Freescale. Main products comprise IC,Modules,Potentiometer,IC Socket,Relay,Connector.Our parts cover such applications as commercial,industrial, and automotives areas.

We are looking forward to setting up business relationship with you and hope to provide you with the best service and solution. Let us make a better world for our industry!



Contact us

Tel: +86-755-8981 8866 Fax: +86-755-8427 6832

Email & Skype: info@chipsmall.com Web: www.chipsmall.com

Address: A1208, Overseas Decoration Building, #122 Zhenhua RD., Futian, Shenzhen, China



PART NUMBER	SML-LXL99MWC-TR/5	REV.	
DATE	E.C.N. NUMBER AND REVISION COMMENTS	REV.	
06.15.10	E.C.N. #: 11648 & REDRAWN	A	

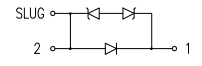
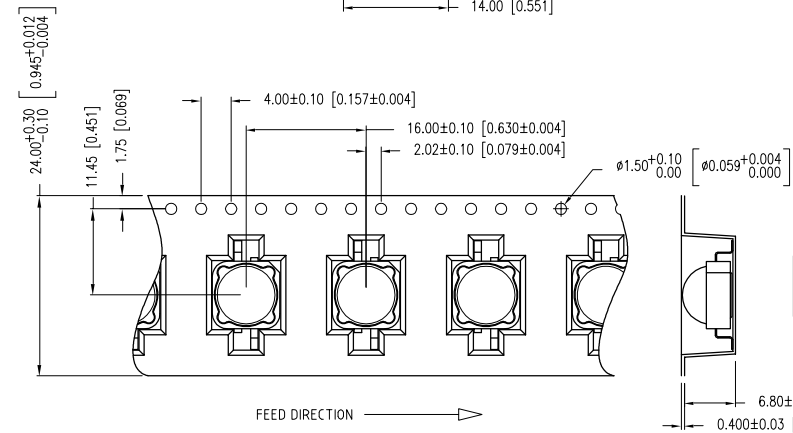
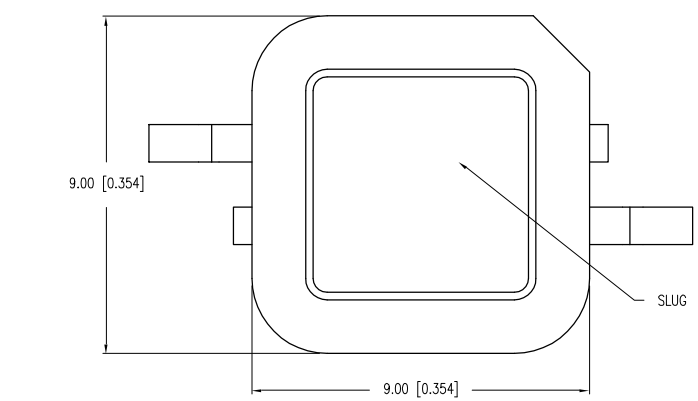
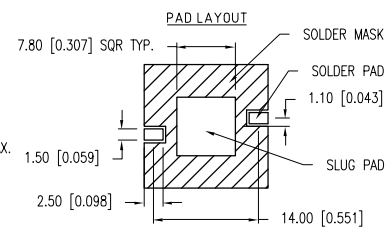
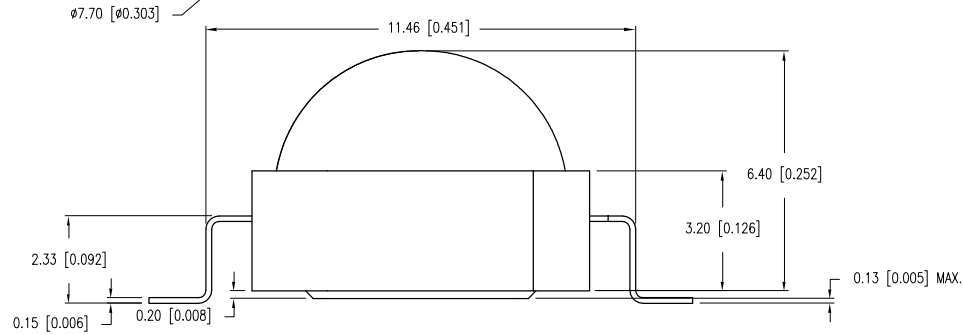
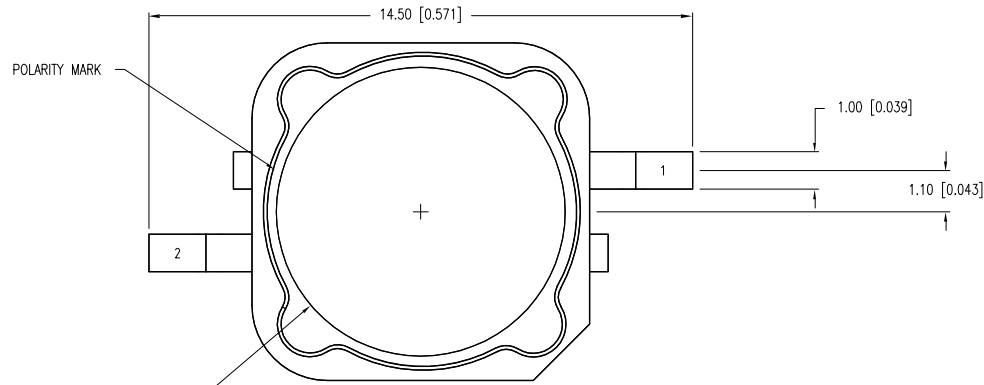

CAUTION: STATIC SENSITIVE DEVICE
FOLLOW PROPER E.S.D. HANDLING PROCEDURES
WHEN WORKING WITH THIS PART.

ELECTRO-OPTICAL CHARACTERISTICS $T_A=25^{\circ}\text{C}$ $I_f=1200\text{mA}$

PARAMETER	MIN	TYP	MAX	UNITS	TEST COND
PEAK WAVELENGTH		4.5	5.1	nm	
FORWARD VOLTAGE				V_f	$I_f = 1200\text{mA}$
REVERSE VOLTAGE	5.0			V_r	$I_f = 100\mu\text{A}$
AXIAL INTENSITY	140	220		lm	$I_f = 1200\text{mA}$
COLOR TEMP	2580	2700	2870	K	
VIEWING ANGLE		100		$2x$ theta	
EMITTED COLOR:	WHITE				
EPOXY LENS FINISH:	WATER CLEAR				

LIMITS OF SAFE OPERATION AT 25°C

PARAMETER	MAX	UNITS
PEAK FORWARD CURRENT*	1500	mA
STEADY CURRENT	1200	mA
LED JUNCTION TEMPERATURE	110	$^{\circ}\text{C}$
DERATE FROM 25°C	- 1.2	mW/ $^{\circ}\text{C}$
OPERATING, STORAGE TEMP.	-40 TO +100	$^{\circ}\text{C}$
IRON SOLDERING	350	$^{\circ}\text{C}$
SOLDERING TIME	3	SEC

* $T < 10\mu\text{s}$

NOTES:
1. NOT REFLOW SOLDERING COMPATIBLE.

