



Chipsmall Limited consists of a professional team with an average of over 10 year of expertise in the distribution of electronic components. Based in Hongkong, we have already established firm and mutual-benefit business relationships with customers from,Europe,America and south Asia,supplying obsolete and hard-to-find components to meet their specific needs.

With the principle of “Quality Parts,Customers Priority,Honest Operation,and Considerate Service”,our business mainly focus on the distribution of electronic components. Line cards we deal with include Microchip,ALPS,ROHM,Xilinx,Pulse,ON,Everlight and Freescale. Main products comprise IC,Modules,Potentiometer,IC Socket,Relay,Connector.Our parts cover such applications as commercial,industrial, and automotives areas.

We are looking forward to setting up business relationship with you and hope to provide you with the best service and solution. Let us make a better world for our industry!



Contact us

Tel: +86-755-8981 8866 Fax: +86-755-8427 6832

Email & Skype: info@chipsmall.com Web: www.chipsmall.com

Address: A1208, Overseas Decoration Building, #122 Zhenhua RD., Futian, Shenzhen, China



Applications

- Low loss, high power switches
- Low distortion attenuators

Features

- Low profile, ultraminiature 2 x 2 mm QFN surface mount package with exposed paddle
- Low thermal resistance (40 °C/W)
- Suitable for 50 W CW T-R switches
- Low capacitance (0.3 pF)
- Low distortion performance
- Lead (Pb)-Free, Green™, fully compliant with RoHS requirements
- ESD Class 1C, human body model

SMP1302-085LF: Surface Mount PIN Diode for High Power Switch Applications

The SMP1302-085LF is a surface mountable, low capacitance silicon PIN diode in a low thermal resistance QFN-2, 2 x 2 mm plastic package. The SMP1302-085LF is designed as a shunt connected PIN diode for high power, high volume switch and attenuator applications from 10 MHz to beyond 6 GHz. Maximum resistance at 100 mA is 1.5 W and maximum capacitance at 30 V is 0.3 pF.

The combination of low junction capacitance, low parasitic inductance, low thermal resistance and nominal 50 μ m I region width, makes these diodes useful in large signal switches and attenuator applications.

With its 3 W dissipation power rating the SMP1302-085LF is capable of handling more than 50 W CW and 500 W peak (1 μ s pulse, 1% duty cycle), in a shunt connected T-R switch. The SMP1302 is described in a 41 dBm T-R switch designed at 2 GHz which operated with low loss, high isolation and low distortion.

Design information for high power switches may be found in the Skyworks Application Note *Design with PIN Diodes*.

The 085 package is lead (Pb)-free and fully complies with Skyworks definition of Green: it meets all current RoHS requirements and contains no antimony (Sb) and no halogens, such as bromine (Br).

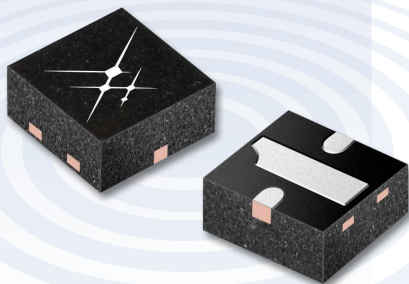

Innovation to Go™
New! Free Designer Kits

Select products and sample/designer kits available for purchase online.

www.skyworksin.com



Operating Characteristics

$T = 25\text{ }^{\circ}\text{C}$, unless otherwise noted

Parameter	Symbol	Condition	Min.	Typ.	Max.	Unit
Reverse current	I_R	$V_R = 200\text{ V}$			10	μA
Capacitance	C_{T30}	$V_R = 30\text{ V}$, $f = 1\text{ MHz}$			0.3	pF
Resistance	R_{S10}	$I_F = 10\text{ mA}$, $f = 100\text{ MHz}$			3	Ω
Resistance	R_{S100}	$I_F = 100\text{ mA}$, $f = 100\text{ MHz}$		1.0	1.5	Ω
Forward voltage	V_F	$I_F = 10\text{ mA}$		0.8		V
Carrier lifetime	T_L	$I_F = 10\text{ mA}$		700		ns
I-Region width	W			50		μm
CW thermal resistance	Θ_{JC}				40	$^{\circ}\text{C}/\text{W}$
Pulse thermal resistance	Θ_p	Single $1\text{ }\mu\text{s}$ pulse		3.5		$^{\circ}\text{C}/\text{W}$

Typical Performance Data @ $25\text{ }^{\circ}\text{C}$, unless otherwise noted

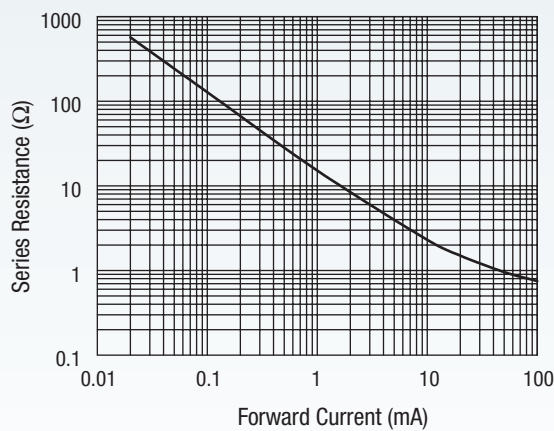

Series Resistance vs. Current @ 100 MHz

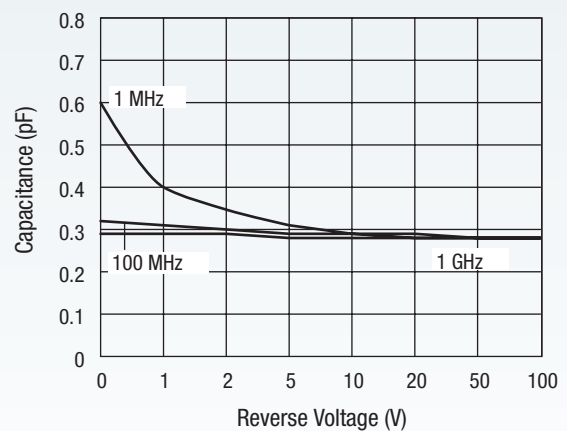

Capacitance vs. Reverse Voltage

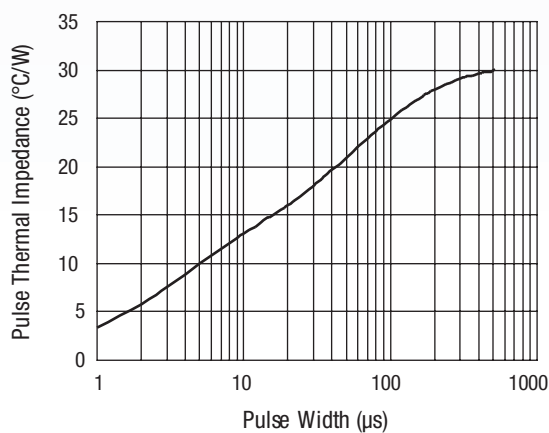

Typical Pulse Thermal Impedance

Absolute Maximum Ratings

Characteristic	Value
Reverse voltage	200 V
Forward current at $25\text{ }^{\circ}\text{C}$	1.5 A
CW power dissipation at $25\text{ }^{\circ}\text{C}$	3 W
$1\text{ }\mu\text{s}$ pulse power dissipation	30 W
Storage temperature range	$-65\text{ }^{\circ}\text{C}$ to $+200\text{ }^{\circ}\text{C}$
Operating temperature range	$-40\text{ }^{\circ}\text{C}$ to $+150\text{ }^{\circ}\text{C}$

Performance is guaranteed only under the conditions listed in the specifications table and is not guaranteed under the full range(s) described by the Absolute Maximum specifications. Exceeding any of the absolute maximum/minimum specifications may result in permanent damage to the device and will void the warranty.

T-R Switch Performance

Frequency	2010-2025 GHz
Insertion loss (Tx-ANT)	0.42 dB
Insertion loss (ANT-Rx)	0.45 dB
Isolation (Rx-Tx)	37 dB
Isolation (Tx-Rx)	37.8dB
0.1 dB Tx compression	46 dBm (Pulsed)
1.0 dB Tx compression	>50 dBm (Pulsed)
Tx-Rx IIP3	>80 dBm
Tx CW input power	41 dBm
Tx Peak input power ⁽²⁾	>49.5 dBm
Rx CW input power	41 dBm
Tx-Rx switching speed ⁽¹⁾	<0.85 μ s
Tx input return loss	27.8 dB
Rx input return loss	28.8 dB

1. Based on complementary pulsed bias current waveforms under RF conditions.

2. Measured with 8 μ s RF pulse width, 0.5% duty cycle, 50 Ω ANT load.

3. F1 = 2.0155 GHz @ 10 dBm, F2 = 2.0195 GHz @ 10 dBm.

High Power Switch Design Application

A T-R switch incorporating SMP1302 PIN diodes covering 2.0155 GHz to 2.0195 GHz has been designed and tested. The switch operated safely at transmitter power of 41dBm CW (12.6 W) with low insertion loss (0.42 dB) and high receiver isolation (37 dB). 1 dB compression occurred at higher than 50 dBm. In the receive state the switch performed with 0.45 dB insertion loss and 37.8 dB transmitter isolation.

The circuit is based on a quarter wave design utilizing two shunt connected SMP1302 diodes. In the transmit state the Bias 1 is set at 0 mA and Bias 2 is set at 50 mA; in the receive state Bias 1 is set at 50 mA and Bias 2 is set at 0 mA.

T-R Switch Circuit Diagram

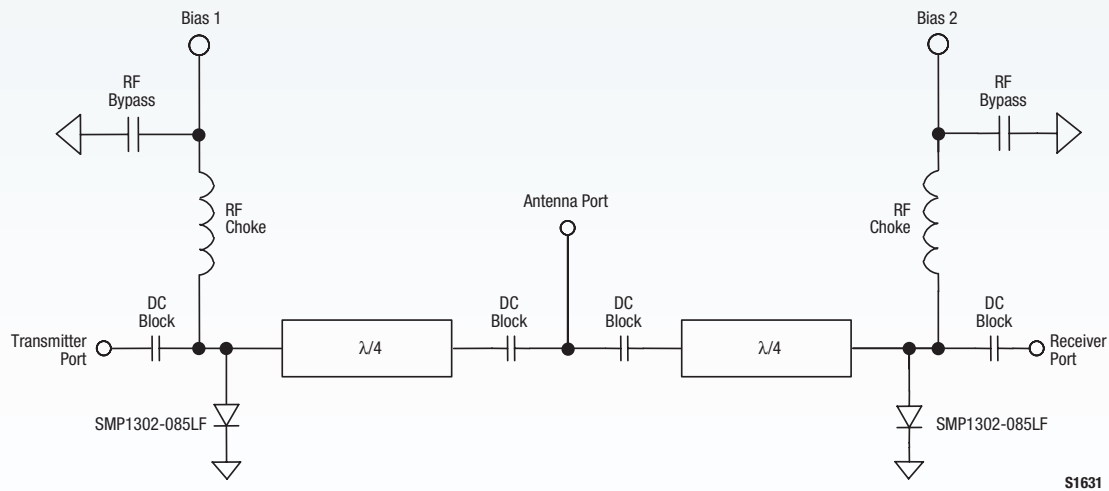

Microstrip Mount

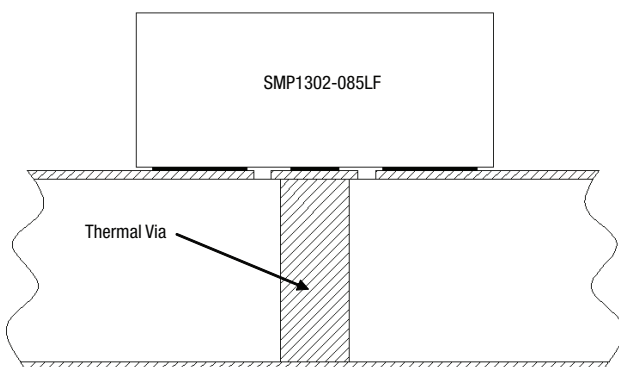

Land Pattern

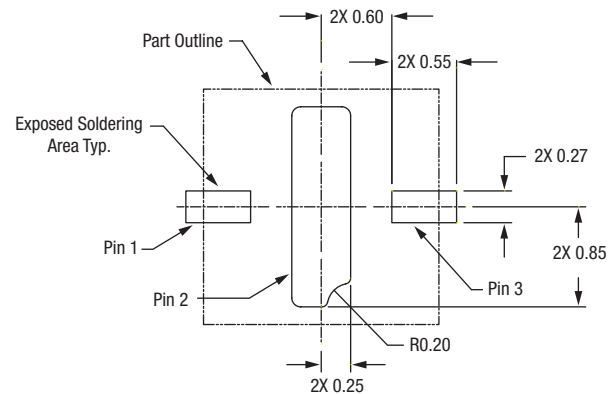

Outline Drawing

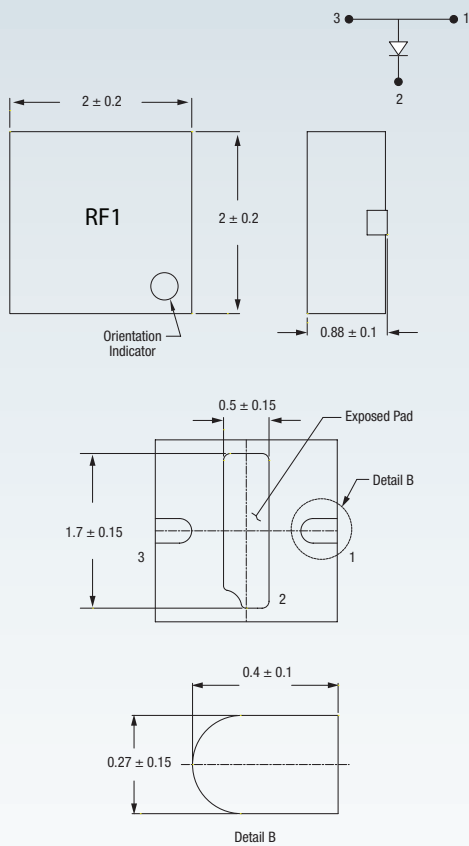

Note: Dimensions are in millimeters.

Application Notes

For additional information, please refer to the following Application Notes.

Solder Reflow Information

Discrete Devices and IC Switch/Attenuators Tape and Reel Package Orientation



Through our Green Initiative™, we are committed to manufacturing products that comply with global government directives and industry requirements.

Skyworks is continuously innovating RF, analog and mixed-signal ICs. For the latest product introductions and information about Skyworks, visit our Web site at www.skyworksinc.com

For additional information on our broad overall product portfolio, please contact your local sales office or email us at sales@skyworksinc.com.

Skyworks Solutions, Inc.

20 Sylvan Road, Woburn, MA 01801

USA: (781) 376-3000 • Asia: 886 2 2735 0399 x 990

Europe: 33 (0)1 41443660 • Fax: (781) 376-3100

Email: sales@skyworksinc.com • www.skyworksinc.com

BRO380-10A Printed on Recycled Paper.

