



Chipsmall Limited consists of a professional team with an average of over 10 year of expertise in the distribution of electronic components. Based in Hongkong, we have already established firm and mutual-benefit business relationships with customers from,Europe,America and south Asia,supplying obsolete and hard-to-find components to meet their specific needs.

With the principle of “Quality Parts,Customers Priority,Honest Operation,and Considerate Service”,our business mainly focus on the distribution of electronic components. Line cards we deal with include Microchip,ALPS,ROHM,Xilinx,Pulse,ON,Everlight and Freescale. Main products comprise IC,Modules,Potentiometer,IC Socket,Relay,Connector.Our parts cover such applications as commercial,industrial, and automotives areas.

We are looking forward to setting up business relationship with you and hope to provide you with the best service and solution. Let us make a better world for our industry!



Contact us

Tel: +86-755-8981 8866 Fax: +86-755-8427 6832

Email & Skype: info@chipsmall.com Web: www.chipsmall.com

Address: A1208, Overseas Decoration Building, #122 Zhenhua RD., Futian, Shenzhen, China



SPECIFICATIONS

| PARAMETERS | VALUES | UNIT |
|-------------------------|------------------------------|-------|
| RATED VOLTAGE | 3.6 | Vp-p |
| OPERATING VOLTAGE RANGE | 2.5 ~ 4.5 | Vp-p |
| RATED CURRENT (MAX) | 90 | mA |
| COIL RESISTANCE | 15 ± 3 | OHM |
| MINIMUM SPL @ 10 CM | 92 | dB |
| RESONANT FREQUENCY | 2,700 ± 500 | Hz |
| OPERATING TEMPERATURE | -30 ~ +70 | °C |
| STORAGE TEMPERATURE | -40 ~ +85 | °C |
| HOUSING MATERIAL | LCP | - |
| TERMINAL MATERIAL | Sn PLATED PHOSPHOR BRONZE | - |
| WEIGHT | 0.42 | grams |

THIS DOCUMENT CONTAINS DATA PROPRIETARY TO PROJECTS UNLIMITED, INC. ANY USE OR REPRODUCTION, IN ANY FORM, WITHOUT PRIOR WRITTEN PERMISSION OF PROJECTS UNLIMITED, INC. IS PROHIBITED.
©2003, Projects Unlimited Inc.

REVISION HISTORY

| LTR | DESCRIPTION | DATE | APPROVED |
|-----|--|------------|----------|
| - | RELEASED FROM ENGINEERING | 4/1/2005 | |
| A | ADDED RoHS COMPLIANCE NOTE | 8/10/2005 | |
| B | REVISED TO INVENTOR 3-D DRAWING TEMPLATE | 5/4/2010 | B.R. |
| C | REVISED SPL VALUE | 10/28/2011 | M.L. |

A (5:1)

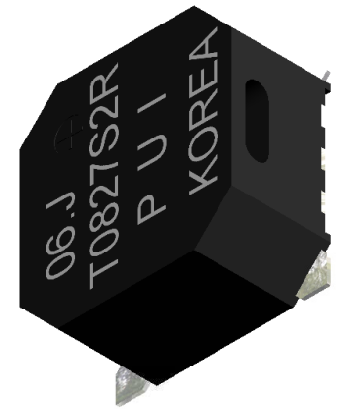
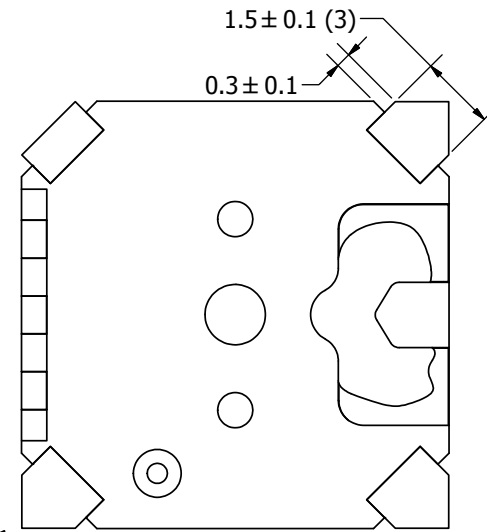
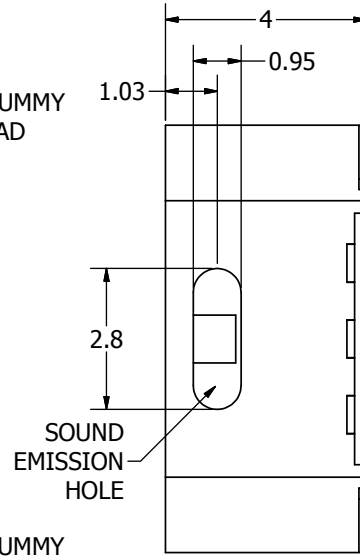
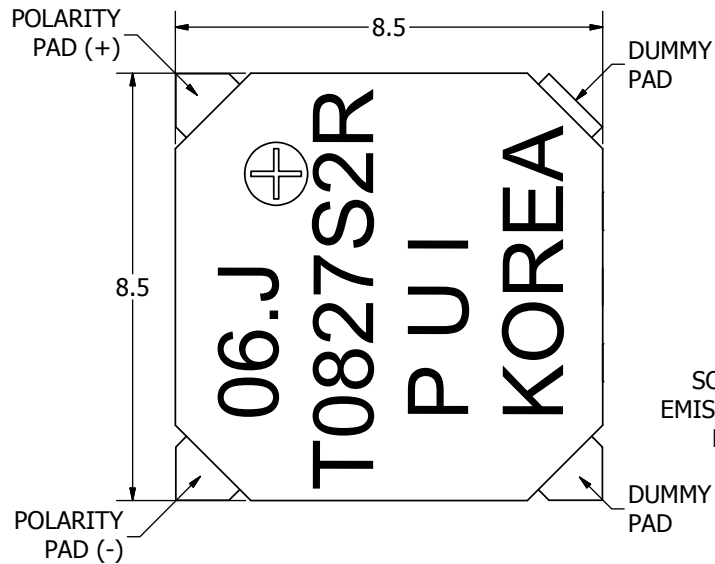
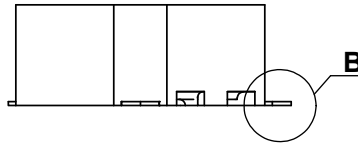

DETAIL "B"

BOTTOM OF TRANSDUCER

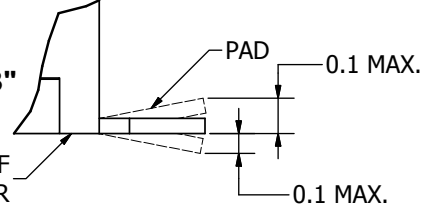

NOTES:

1. ALL DIMENSIONS ARE IN MILLIMETERS.
2. SPECIFICATIONS SUBJECT TO CHANGE OR WITHDRAWAL WITHOUT NOTICE.
3. THIS PART IS RoHS 2002/95/EC COMPLIANT.

| | | | | | | | | | |
|--|-------------------|-------------|----------|------------|-----------------------|---------------------------|----------|--------------|----------------|
| UNLESS OTHERWISE SPECIFIED: DIMENSIONS ARE IN MILLIMETERS, TOLERANCES ARE ±0.5 AND ANGLES ARE ±3°. | SIZE A3 | Designed by | Date | Checked by | Date | Approved by | Date | Drawn Date | |
| | | G.V. | 4/1/2005 | E.P. | 4/1/2005 | R.W. | 4/1/2005 | 5/4/2010 | |
| SMT-0827-S-2-R.idw | | | | | SMT-0827-S-2-R | | | | |
| | | | | | | Transducer (Electro-Mech) | | Edition - | Sheet 1 / 1 |