



Chipsmall Limited consists of a professional team with an average of over 10 year of expertise in the distribution of electronic components. Based in Hongkong, we have already established firm and mutual-benefit business relationships with customers from,Europe,America and south Asia,supplying obsolete and hard-to-find components to meet their specific needs.

With the principle of “Quality Parts,Customers Priority,Honest Operation,and Considerate Service”,our business mainly focus on the distribution of electronic components. Line cards we deal with include Microchip,ALPS,ROHM,Xilinx,Pulse,ON,Everlight and Freescale. Main products comprise IC,Modules,Potentiometer,IC Socket,Relay,Connector.Our parts cover such applications as commercial,industrial, and automotives areas.

We are looking forward to setting up business relationship with you and hope to provide you with the best service and solution. Let us make a better world for our industry!



Contact us

Tel: +86-755-8981 8866 Fax: +86-755-8427 6832

Email & Skype: info@chipsmall.com Web: www.chipsmall.com

Address: A1208, Overseas Decoration Building, #122 Zhenhua RD., Futian, Shenzhen, China



REV.	DESCRIPTION	DATE	APPROVED
B	Engineering Release	02/27/15	J. C.
C	Revised Side View, See Page 4	03/20/15	J. C.
D	Corrected Typo in Recom. Soldering Pattern	09/12/16	J. C.

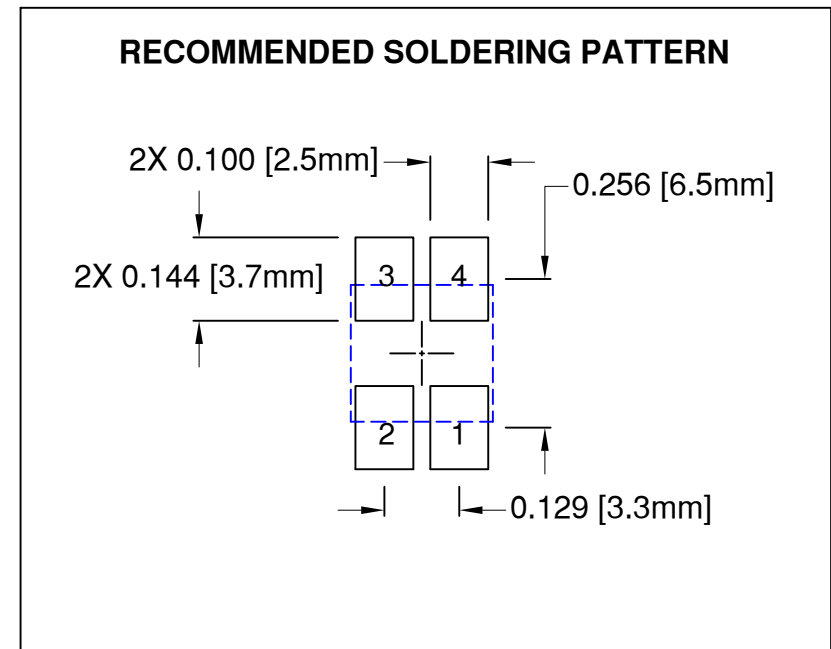
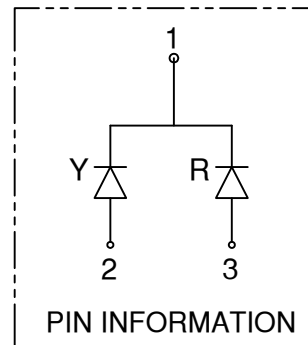
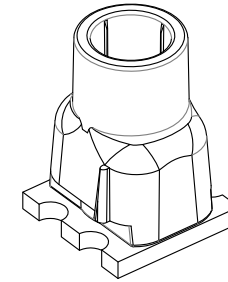
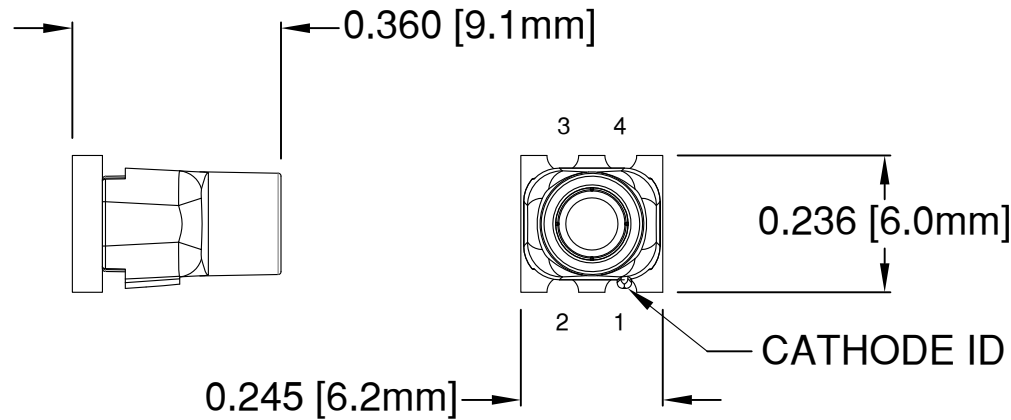

ABSOLUTE MAXIMUM RATINGS at Ta=25°C

REVERSE VOLTAGE	5V
REVERSE CURRENT	100µA
OPERATING TEMPERATURE RANGE	-35°C - 85°C
STORAGE TEMPERATURE	-35°C - 85°C
MAX SOLDERING TEMPERATURE	260°C FOR 3 SECONDS

NOTES:



- DERATING OF FORWARD CURRENT PER SEGMENT, 0.30mA/°C at T ≥ 25°C
- ACCEPTS BIVAR FLEXIBLE LIGHT PIPE STYLE FLPS2031

STANDARD TOLERANCE (UNLESS OTHERWISE SPECIFIED)		 4 THOMAS, IRVINE, CA. 92618 TEL: (949) 951-8808 FAX: (949) 951-3974	
DECIMALS	ANGULAR		
.X ± .1	X° ± 1°	 TITLE: SMT FLP VERTICAL ADAPTER BI-COLOR, RED/YELLOW	
.XX ± .02			
.XXX ± .010			
DESIGNED: A. Wright	DATE: 03/13/14	PART NO: SMTV01-RXXYXX	REVISION: D
CHECKED: B. Oliver	DATE: 03/13/14	CAGE CODE : 32559	SHEET # 1 OF 4
CAD GENERATED DOCUMENT. DO NOT MEASURE DRAWING.			

REV.	DESCRIPTION	DATE	APPROVED
	SEE SHEET #1		

Part Number	Chip				Absolute Maximum Ratings Per Segment			Electro-Optical Data @20mA, 25°C			
	Emitted Color	λ_D [nm]			P_d [mW]	I_f [mA]	Peak I_f [mA]	V_f [V]			I_v [mcd]
		MIN	TYP	MAX				MIN	TYP	MAX	TYP
SMTV01-R08Y08	RED	625	628	630	60	25	100	1.7	2.1	2.6	78
	YELLOW	585	590	595	60	25	100	1.8	2.1	2.6	82
SMTV01-R15Y11	RED	625	628	630	60	25	100	1.7	2.1	2.6	150
	YELLOW	585	590	595	60	25	100	1.8	2.1	2.6	110
SMTV01-R16Y14	RED	625	628	630	60	25	100	1.7	2.1	2.6	163
	YELLOW	585	590	595	60	25	100	1.8	2.1	2.6	143

Note: 10% Duty Cycle, Pulse Width ≤ 0.1 msec for Peak I_f .

STANDARD TOLERANCE (UNLESS OTHERWISE SPECIFIED)		 4 THOMAS, IRVINE, CA. 92618 TEL: (949) 951-8808 FAX: (949) 951-3974	
DECIMALS	ANGULAR		
.X $\pm .1$	X° $\pm 1^\circ$	 TITLE: SMT FLP VERTICAL ADAPTER BI-COLOR, RED/YELLOW	
.XX $\pm .02$			
.XXX $\pm .010$		PART NO: SMTV01-RXXYXX	
DESIGNED: A. Wright	DATE: 03/13/14	REVISION: D	
CHECKED: B. Oliver	DATE: 03/13/14	CAGE CODE : 32559	
		SHEET # 2 OF 4	
CAD GENERATED DOCUMENT. DO NOT MEASURE DRAWING.			

REV.	DESCRIPTION	DATE	APPROVED
	SEE SHEET #1		

Recommended Reflow Soldering Profile

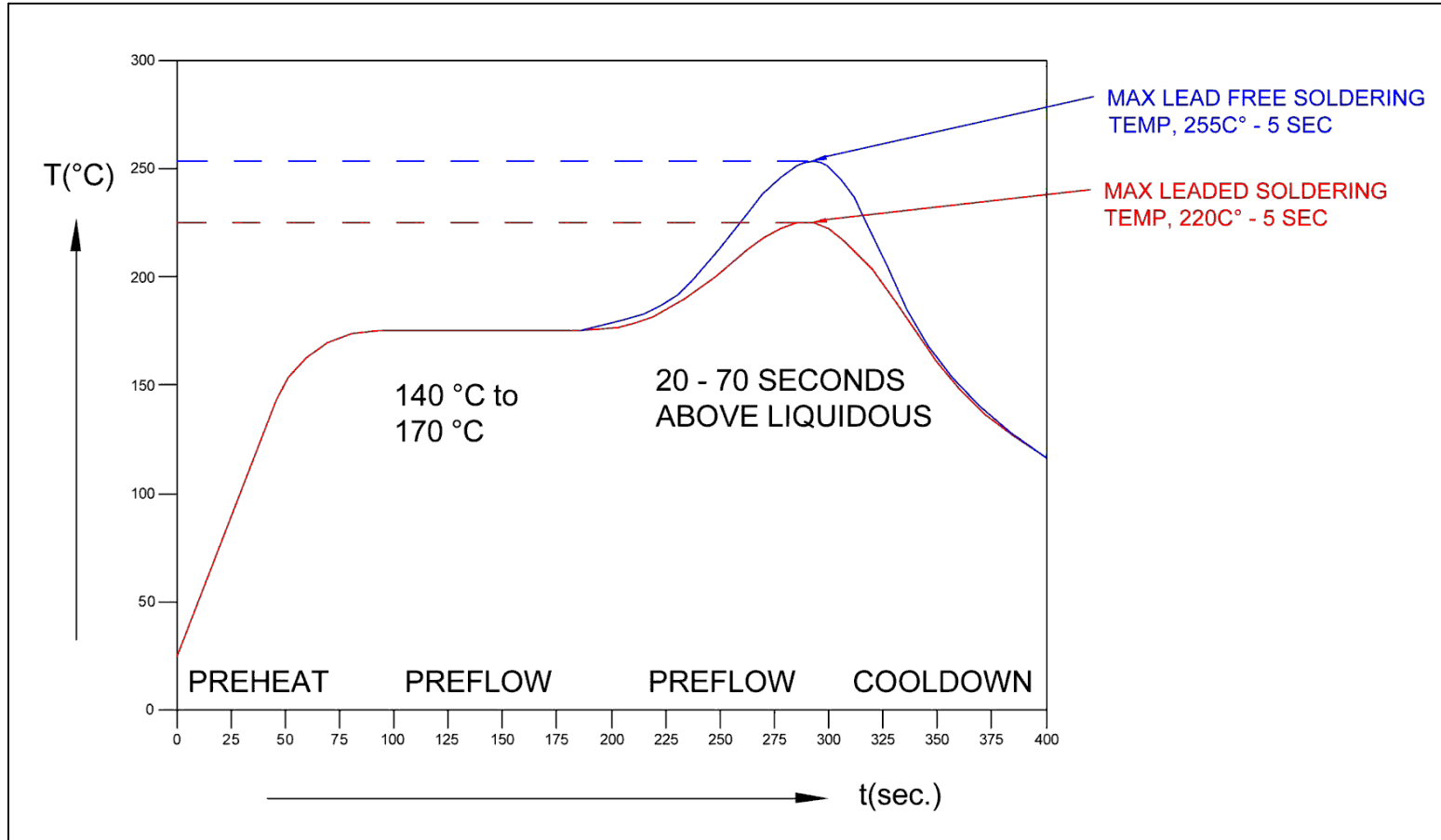

NOTE:
 1. Do not clean after soldering. Only use no-clean solder paste.

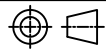
STANDARD TOLERANCE (UNLESS OTHERWISE SPECIFIED)		BIVAR [®] 4 THOMAS, IRVINE, CA. 92618 TEL: (949) 951-8808 FAX: (949) 951-3974			
DECIMALS	ANGULAR				
.X ± .1	X° ± 1°	 TITLE: SMT FLP VERTICAL ADAPTER BI-COLOR, RED/YELLOW			
.XX ± .02					
.XXX ± .010		DESIGNED: A. Wright	DATE: 03/13/14	PART NO: SMTV01-RXXYXX	REVISION: D
		CHECKED: B. Oliver	DATE: 03/13/14	CAGE CODE : 32559	SHEET # 3 OF 4
CAD GENERATED DOCUMENT. DO NOT MEASURE DRAWING.					

REV.	DESCRIPTION	DATE	APPROVED
	SEE SHEET #1		

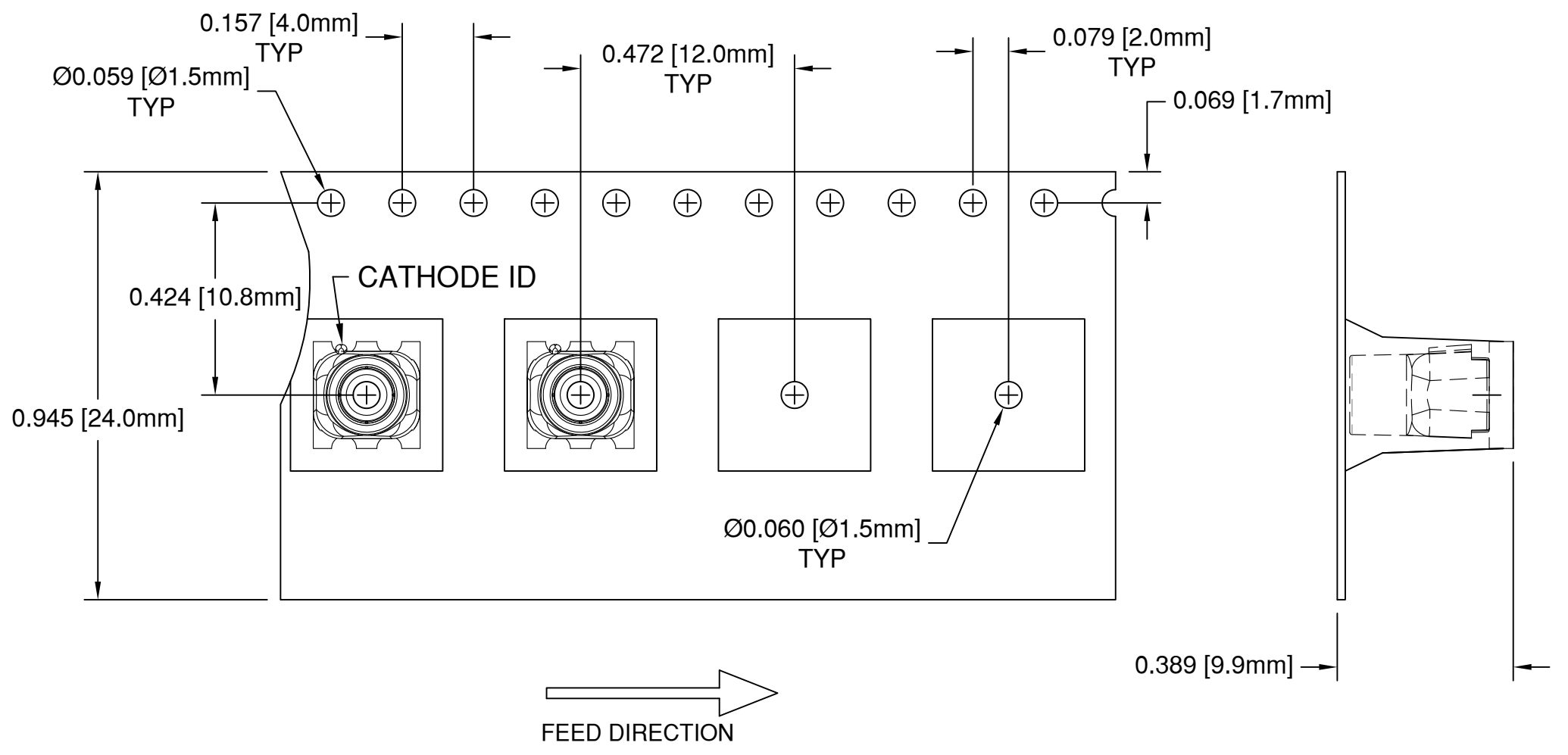

NOTES:
 3. MOISTURE SENSITIVITY LEVEL: 4
 2. UNLESS OTHERWISE SPECIFIED, PACKAGING TO COMPLY WITH EIA-481-D
 1. 500 pcs PER REEL

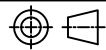
STANDARD TOLERANCE (UNLESS OTHERWISE SPECIFIED)		 4 THOMAS, IRVINE, CA. 92618 TEL: (949) 951-8808 FAX: (949) 951-3974	
DECIMALS	ANGULAR		
.X ± .1	X° ± 1°		TITLE: SMT FLP VERTICAL ADAPTER BI-COLOR, RED/YELLOW
.XX ± .02			DESIGNED: A. Wright
.XXX ± .010		CHECKED: B. Oliver	DATE: 03/13/14
		PART NO: SMTV01-RXXYXX	REVISION: D
		CAGE CODE : 32559	SHEET # 4 OF 4
CAD GENERATED DOCUMENT. DO NOT MEASURE DRAWING.			