



Chipsmall Limited consists of a professional team with an average of over 10 year of expertise in the distribution of electronic components. Based in Hongkong, we have already established firm and mutual-benefit business relationships with customers from,Europe,America and south Asia,supplying obsolete and hard-to-find components to meet their specific needs.

With the principle of "Quality Parts,Customers Priority,Honest Operation,and Considerate Service",our business mainly focus on the distribution of electronic components. Line cards we deal with include Microchip,ALPS,ROHM,Xilinx,Pulse,ON,Everlight and Freescale. Main products comprise IC,Modules,Potentiometer,IC Socket,Relay,Connector.Our parts cover such applications as commercial,industrial, and automotives areas.

We are looking forward to setting up business relationship with you and hope to provide you with the best service and solution. Let us make a better world for our industry!



## Contact us

Tel: +86-755-8981 8866 Fax: +86-755-8427 6832

Email & Skype: info@chipsmall.com Web: www.chipsmall.com

Address: A1208, Overseas Decoration Building, #122 Zhenhua RD., Futian, Shenzhen, China



# SN802GRC-4

## 4-Channel RTD/CT Wi-Fi Sensor Node

- 4 Analog Channel, Battery-Powered Wireless Sensor Node
- 2 RTD Inputs and 2 Current Transformer Inputs Plus 2 Switch Inputs
- Supports 2- and 3-Wire 100 ohm Platinum RTDs
- True RMS Current Measurement
- Switch State and Change-of-State Monitoring
- Non-volatile Data Logging Memory
- Robust IEEE 802.11g Radio
- Internal Antenna or External 2 dBi Antenna Options
- Compatible with b/g/n Access Points
- WPA2 Encryption Provides Strong Data Security
- Configuration Through Wireless Link or Serial Port
- Up to 5 Years Battery Life
- FCC, Canadian IC Certified Unlicensed Operation

The SN802GRC-4 is an IEEE 802.11g-based sensor node supporting two RTD, two current transformer and two switch inputs. The SN802GRC-4's very low average power consumption provides up to 5 years of operating battery life. The Murata WSN802GPA radio used in the SN802GRC-4 can take advantage of existing Wi-Fi access points to lower deployment costs. With Wi-Fi networks widely available and well understood by IT departments, the SN802GRC-4 is easily integrated into existing networks. The SN802GRC-4 is compatible with 802.11b/g/n networks and supports WPA2 encryption, providing strong data security. The SN802GRC-4 can operate at RF data rates from 1 to 11 Mbps, providing plenty of bandwidth for sensor applications.



### SN802GRC-4 Specifications

Characteristic	Sym	Notes	Minimum	Typical	Maximum	Units
Sensor Inputs			2 or 3-wire 100 ohm Platinum RTDs Current Transformers Contact Closures			
RTD Temperature Range			-200		+600	°C
RTD Resolution				0.0625		°C
RTD Accuracy				±0.3		°C
RTD Measurement Data Format			16-bit Signed Value			
Input Range for Current Transformer			0		3.34	mA <sub>RMS</sub>
Current Measurement Resolution				16		bits
Current Measurement Accuracy					±2	%
Current Measurement Data Format			16-bit Unsigned Value			
Open Contact Voltage				3.3		V
Closed Contact Current				33		µA
Contact Status Data Format			8-bit Unsigned Value			

## SN802GRC-4 Specifications

Characteristic	Sym	Notes	Minimum	Typical	Maximum	Units
Internal Battery Voltage Range			3.0		3.6	V
Internal Battery Voltage Accuracy					±2	%
Internal Battery Voltage Data Format			16-bit Unsigned Value			
Serial Interface			RS232C, 38.4 kbps, 8N1, no flow control			
Radio			Murata WSN802GPA IEEE 802.11g module			
Operating Frequency Range			2401		2474	MHz
Supported RF Data Rates			1, 2, 5.5 and 11			Mbps
Number of RF Channels				11		
RF Transmit Power, EIRP, Chip Antenna				10		mW
RF Transmit Power, EIRP, 2 dBi Dipole Antenna				15.8		mW
Receiver Sensitivity, 8% PER:						
1 Mbps RF Data Rate				-92		dBm
2 Mbps RF Data Rate				-90		dBm
5.5 Mbps RF Data Rate				-84		dBm
11 Mbps RF Data Rate				-81		dBm
Internal Antenna			SMD Chip Antenna			
Optional External Antenna			2 dBi RPSMA Dipole Antenna			
Supplied Battery			Lithium Thionyl Chloride (LTC) C Cell, 8.5 A-hr			
Operating Battery Life					5	Years
Operating Temperature Range			-40		+85	°C
Operating Humidity Range, Non-condensing			5		95	%RH
Nominal Dimensions			5.5 x 2.5 x 1.3 inches 140 x 64 x 33 mm			
Mounting			Left and Right Flanges, Two Pre-drilled Holes Plus Slot in Each Flange			



## SN802GRC-4 Block Diagram

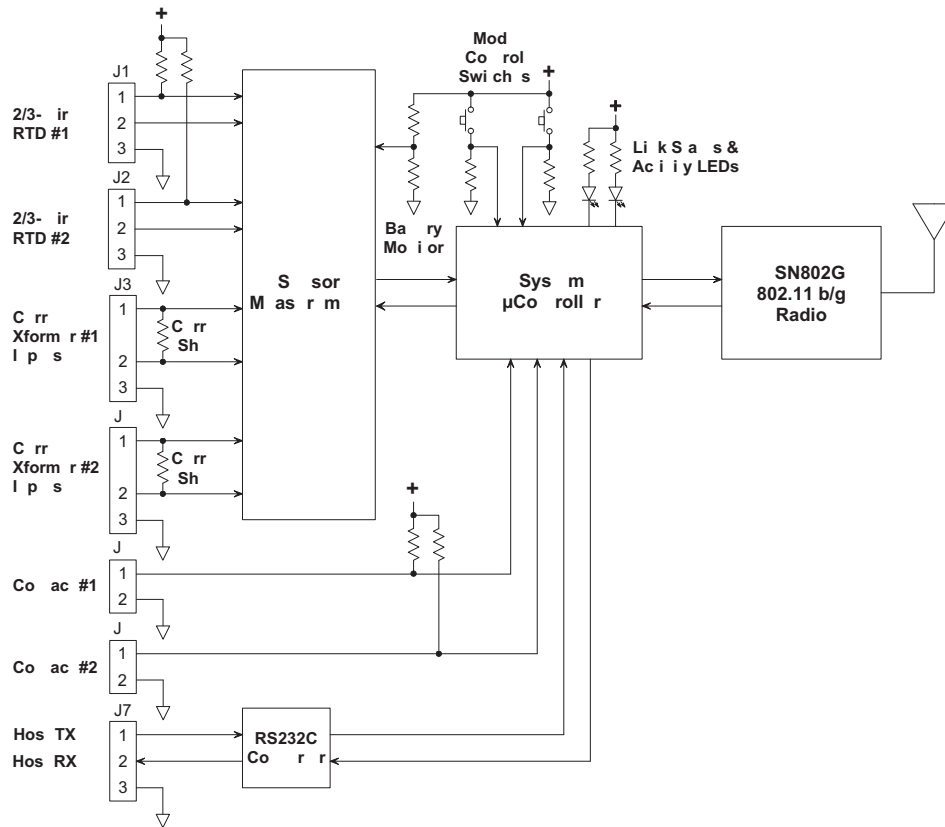

Figure 1

### SN802GRC-4 Operation

The SN802GRC-4 is an IEEE 802.11g-based wireless sensor node that supports two 100 ohm platinum RTDs, two current transformer inputs and two switch inputs. The SN802GRC-4 includes internal storage for more than 1500 time-stamped sets of readings, where each set includes the four analog channels and the two switch inputs. The SN802GRC-4's very low average power consumption provides up to 5 years of operation from a 8.5 A-hr C cell LTC battery. Alternately, the SN802GRC-4 can be powered from three inexpensive AA batteries in limited temperature range applications where shorter battery operating life is acceptable.

The SN802GRC-4 sensor node is available with either an internal antenna or an external 2 dBi dipole antenna.

The Murata WSN802G radio used in the SN802GRC-4 sensor modem communicates through Wi-Fi access points. Optional WPA2 encryption provides strong data security. The SN802GRC-4 can be configured to operate on any of the eleven 2.4 GHz channels defined for

802.11 operation, allowing it to be used in most regions of the world.

The SN802GRC-4 automatically reports the sensor input readings on user defined intervals and conditions, eliminating the need for application polling. The SN802GRC-4 achieves low power consumption by maintaining association with an access point while sleeping. When the SN802GRC-4 sends data, it only has to wake up and send data; it does not have to reestablish a connection with the access point. The internal battery voltage is included in the sensor report, providing continual information on the battery status.

The SN802GRC-4 can be configured over-the-air through a supplied utility, or through user-supplied SNMP tools. The SN802GRC-4 is also configurable through the local serial port using a standard 3-wire RS-232 connection. In addition to reporting conditions, users can configure SSIDs, security keys, destination IP addresses, select DHCP or Static IP address operation, and serial port parameters.

### Connector J1 and J2 Description, 2- or 3-Wire RTD Input

Pin	Name	I/O	Description
1	RTD+	I	3-wire RTD positive (red) input. This input is connected to the RTD current source and the ADC positive differential input.
2	RTD-	I	First 3-wire RTD negative (black) input. This input is connected to the ADC negative differential input. This input is not used with a 2-wire RTD.
3	RTD-/GND	I	Second 3-wire RTD negative (black) input or 2-wire RTD negative input. This input is connected to the RTD ground return.

### Connector J3 and J4 Description, Current Transformer Input

Ref	Name	I/O	Description
1	CURRENT 1	I	First current transformer input. There is a 300 ohm current shunt between this terminal and terminal 2.
2	CURRENT 2	I	Second current transformer input.
3	GND	-	Ground terminal.

### Connector J5 and J6 Description, Contact Input

Ref	Name	I/O	Description
1	CONTACT	I	Contact input. This terminal is connected to +3.3 V through a 100 K resistor.
2	GND	-	Contact ground terminal.

### Connector J7 Description, 3-Wire RS232

Ref	Name	I/O	Description
1	HOST TX	I	Input terminal for host RS232 TX.
2	HOST RX	O	Output terminal for host RS232 RX.
3	GND	-	RS232 ground terminal.

# SN802GRC-4 Cas Dim sio s

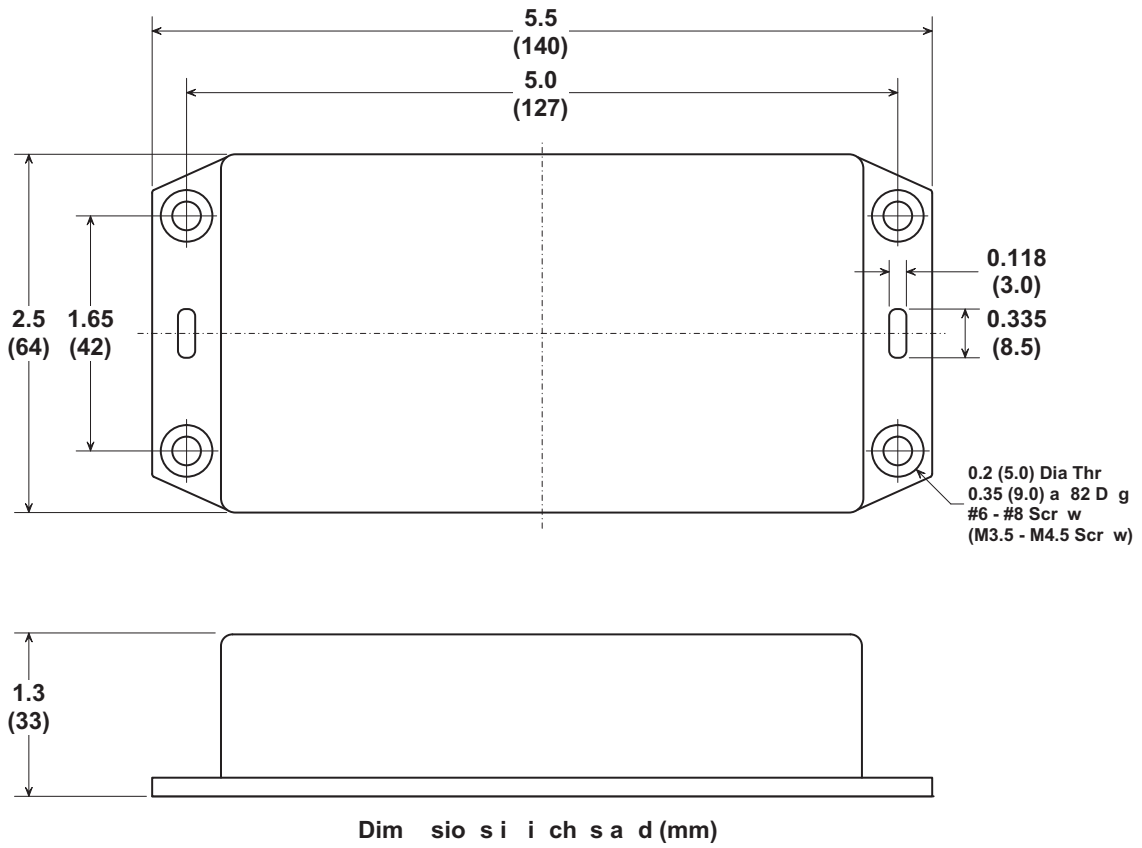

Figure 2

Note: Specifications subject to change without notice.