



Chipsmall Limited consists of a professional team with an average of over 10 year of expertise in the distribution of electronic components. Based in Hongkong, we have already established firm and mutual-benefit business relationships with customers from,Europe,America and south Asia,supplying obsolete and hard-to-find components to meet their specific needs.

With the principle of “Quality Parts,Customers Priority,Honest Operation,and Considerate Service”,our business mainly focus on the distribution of electronic components. Line cards we deal with include Microchip,ALPS,ROHM,Xilinx,Pulse,ON,Everlight and Freescale. Main products comprise IC,Modules,Potentiometer,IC Socket,Relay,Connector.Our parts cover such applications as commercial,industrial, and automotives areas.

We are looking forward to setting up business relationship with you and hope to provide you with the best service and solution. Let us make a better world for our industry!



Contact us

Tel: +86-755-8981 8866 Fax: +86-755-8427 6832

Email & Skype: info@chipsmall.com Web: www.chipsmall.com

Address: A1208, Overseas Decoration Building, #122 Zhenhua RD., Futian, Shenzhen, China



THE INFORMATION CONTAINED IN THIS DRAWING IS THE SOLE PROPERTY OF BUD INDUSTRIES INC. ANY REPRODUCTION IN PART OR WHOLE WITHOUT THE WRITTEN PERMISSION OF BUD INDUSTRIES INC. IS PROHIBITED.

| ISSUE | | REVISIONS |
|-------|-----------------|--------------|
| (A) | REVISED DESIGN | 6-30-08 DAB |
| (B) | PER ECN # 10404 | 11-24-08 DAB |
| (C) | PER ECN # 10446 | 1-13-09 BT |

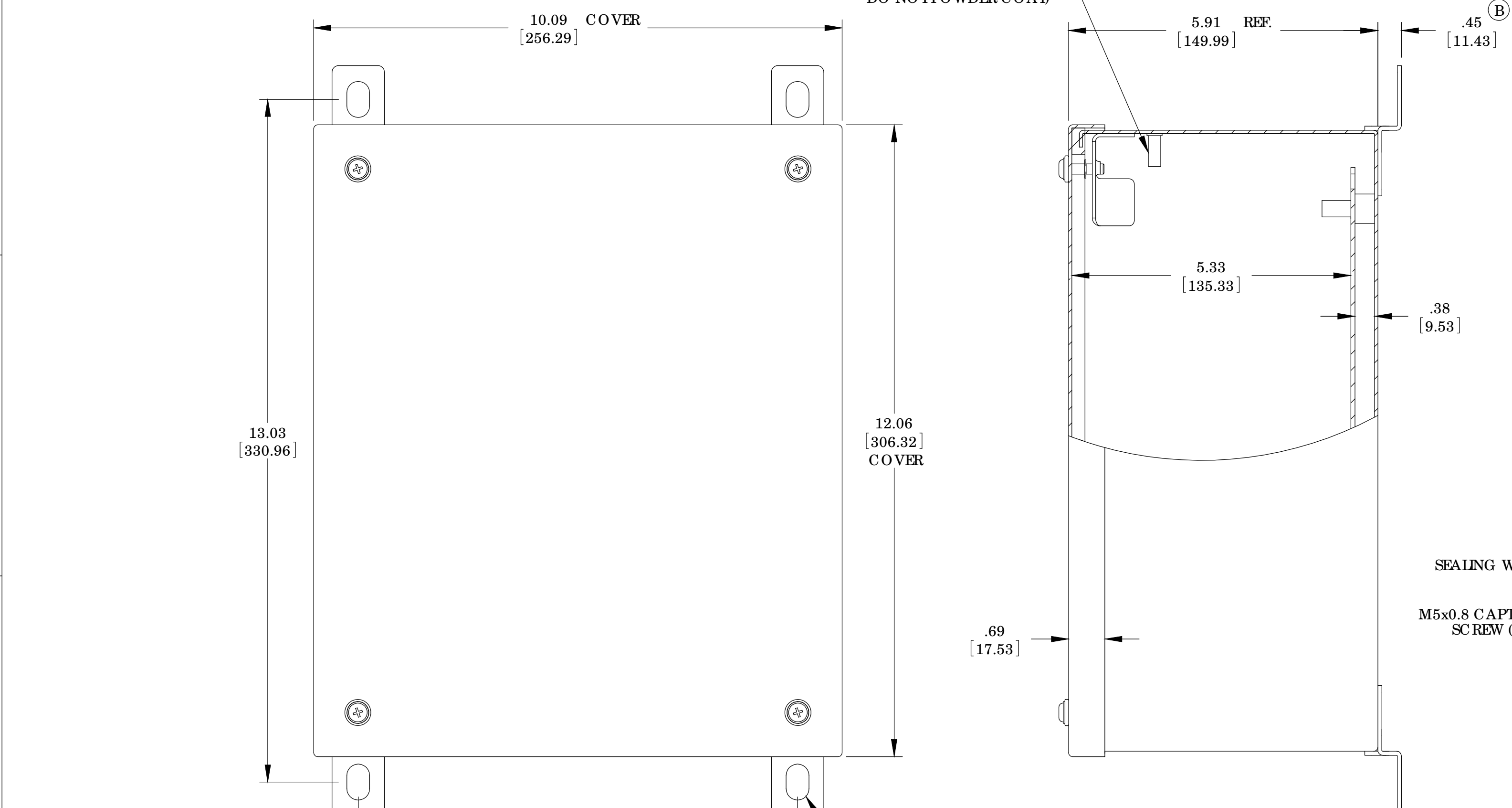

MATERIAL:
 BODY, COVER MOUNTING BRACKETS, COVER - 16 GA. [1.5mm] C.R.S.
 INTERNAL PANEL - 14 GA. [2.0mm] C.R.S.
 WALL MOUNTING BRACKETS - 14 GA. [2.0mm] STAINLESS STEEL
 HARDWARE - STAINLESS STEEL
 GASKET - .25 [6.35] THICK NBR PRENE (BLACK) OR EQUIVALENT
 SEALING WASHERS - BLACK NBR PRENE OR EQUIVALENT

FINISH:
 BODY & COVER - LIGHT GRAY SMOOTH POWDER COAT
 INTERNAL PANEL - ZINC CHROMATE
 WALL MOUNTING BRACKETS - NATURAL

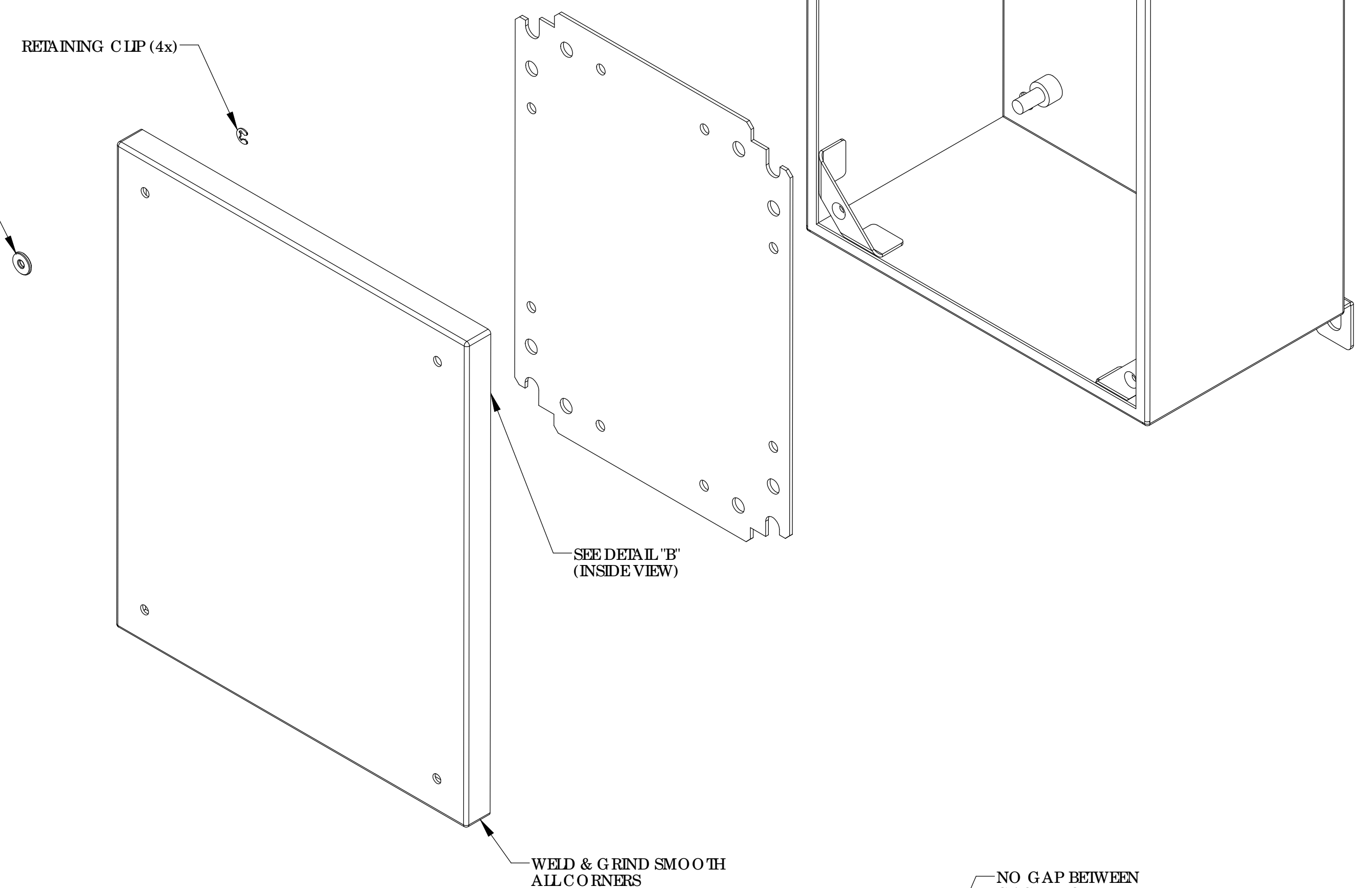

WALL MOUNTING BRACKET KIT TO CONTAIN THE FOLLOWING:
 (4) BRACKETS, (4) BOLTS, (4) SEALING WASHERS, (4) FLAT WASHERS, (4) LOCKWASHERS & (4) HEX NUTS

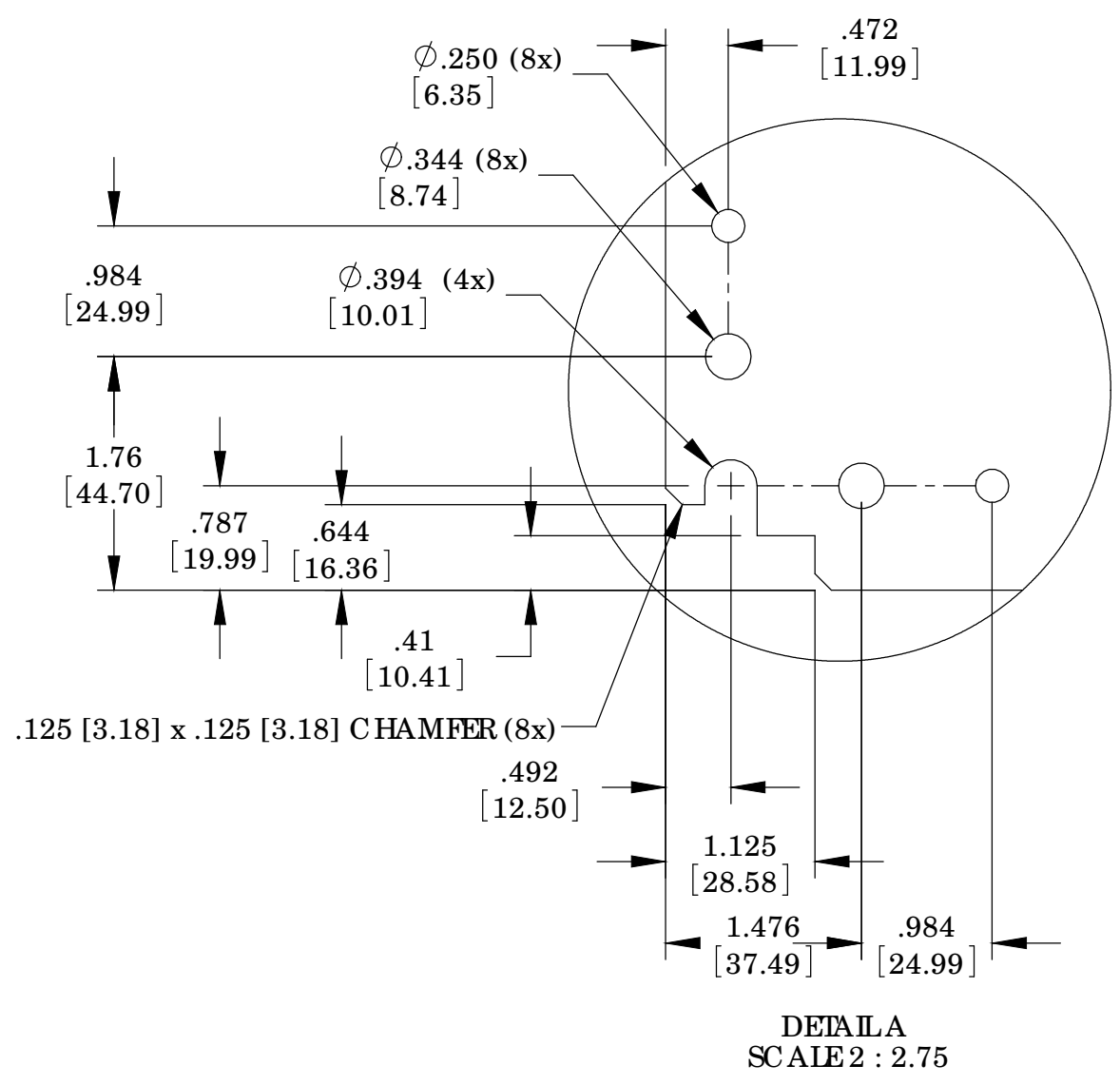
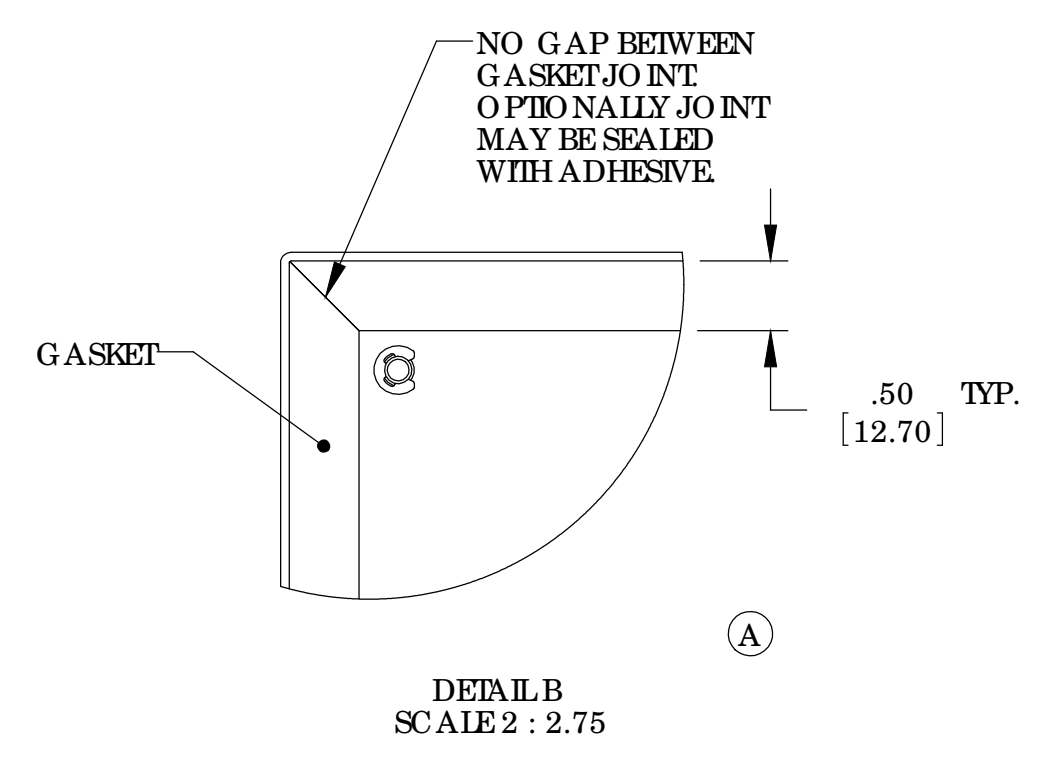
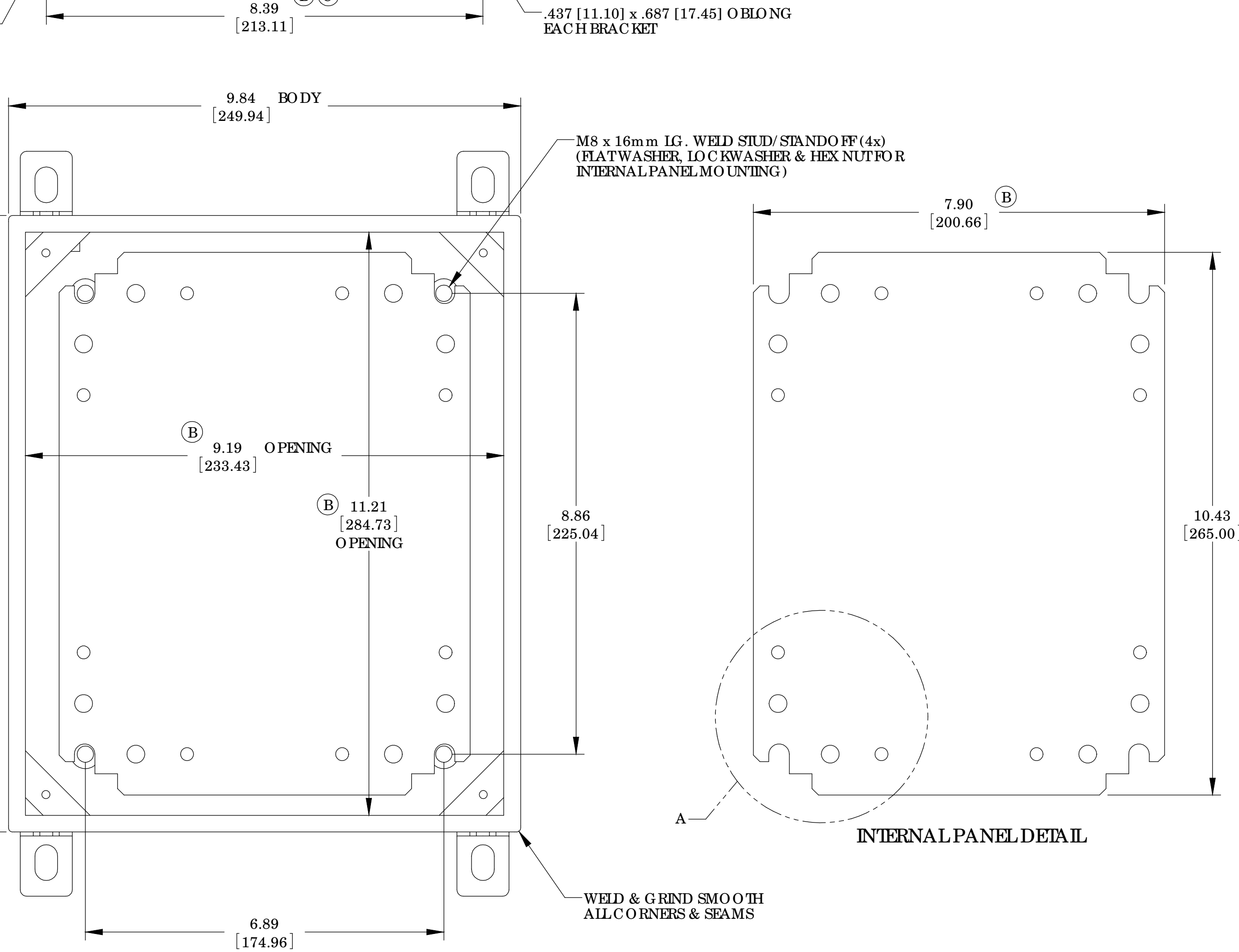

| UNLESS OTHERWISE SPECIFIED ALL DIMENSIONS ARE IN INCHES (MILLIMETERS) | | CAD GENERATED DRAWING - DO NOT MANUALLY UPDATE | | BUD INDUSTRIES INC. | |
|-----------------------------------------------------------------------|----------|------------------------------------------------|---------------------------------------------|---------------------|--------------|
| DESIGNED BY | DAB | APPROVED BY | DAB | DATE | 5-5-08 |
| DRAWN BY | DAB | DATE | NEMA SHEET METAL BOX w/LIFT-OFF SCREW COVER | | |
| MATERIAL | AS NOTED | APPROVED | SCALE | CAD FILE | SYBET 1 OF 1 |

| QTY | USED ON | DO NOT SCALE DRAWING | SCALE | CAD FILE | SYBET 1 OF 1 |
|-----|---------|----------------------|-------|----------|--------------|
| | | | | | |