



Chipsmall Limited consists of a professional team with an average of over 10 year of expertise in the distribution of electronic components. Based in Hongkong, we have already established firm and mutual-benefit business relationships with customers from,Europe,America and south Asia,supplying obsolete and hard-to-find components to meet their specific needs.

With the principle of “Quality Parts,Customers Priority,Honest Operation,and Considerate Service”,our business mainly focus on the distribution of electronic components. Line cards we deal with include Microchip,ALPS,ROHM,Xilinx,Pulse,ON,Everlight and Freescale. Main products comprise IC,Modules,Potentiometer,IC Socket,Relay,Connector.Our parts cover such applications as commercial,industrial, and automotives areas.

We are looking forward to setting up business relationship with you and hope to provide you with the best service and solution. Let us make a better world for our industry!



Contact us

Tel: +86-755-8981 8866 Fax: +86-755-8427 6832

Email & Skype: info@chipsmall.com Web: www.chipsmall.com

Address: A1208, Overseas Decoration Building, #122 Zhenhua RD., Futian, Shenzhen, China



THE INFORMATION CONTAINED IN THIS DRAWING IS THE SOLE PROPERTY OF BUD INDUSTRIES INC. ANY REPRODUCTION IN PART OR WHOLE WITHOUT THE WRITTEN PERMISSION OF BUD INDUSTRIES INC. IS PROHIBITED.

SNC-3757	
ISSUE	REVISIONS
(A)	REVISED DESIGN 6-30-08 DAB
(B)	PER BCN # 10404 12-4-08 DAB
(C)	PER BCN # 10446 1-13-09 BT

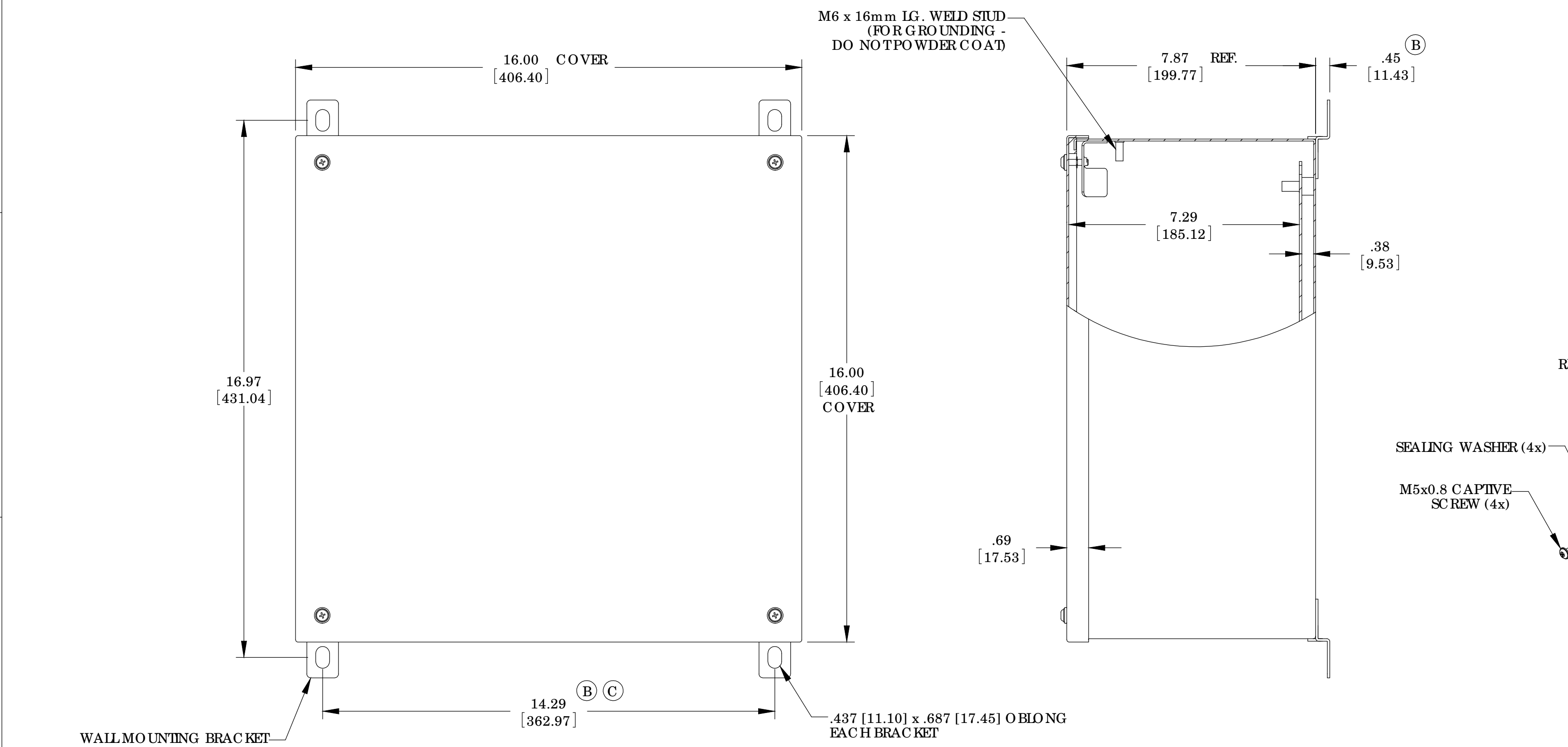

MATERIAL:
 BODY, COVER MOUNTING BRACKETS, COVER - 16 GA. [1.5mm] C.R.S.
 INTERNAL PANEL - 14 GA. [2.0mm] C.R.S.
 WALL MOUNTING BRACKETS - 14 GA. [2.0mm] STAINLESS STEEL
 HARDWARE - STAINLESS STEEL
 GASKET - .25 [6.35] THICK NBR PRENE (BLACK OR EQUIVALENT)
 SEALING WASHERS - BLACK NBR PRENE OR EQUIVALENT

FINISH:
 BODY & COVER - LIGHT GRAY SMOOTH POWDER COAT
 INTERNAL PANEL - ZINC CHROMATE
 WALL MOUNTING BRACKETS - NATURAL

WALL MOUNTING BRACKET KIT TO CONTAIN THE FOLLOWING:
 (4) BRACKETS, (4) BOLTS, (4) SEALING WASHERS, (4) FLAT WASHERS, (4) LOCK WASHERS & (4) HEX NUTS

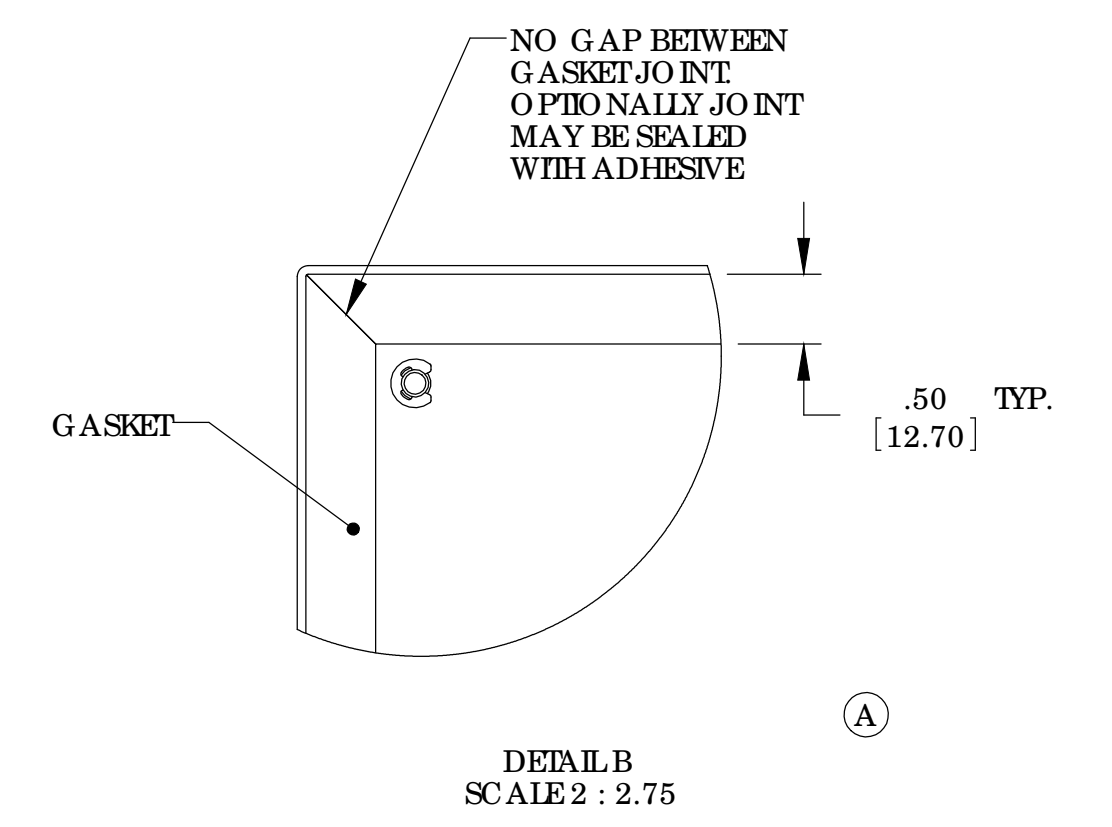
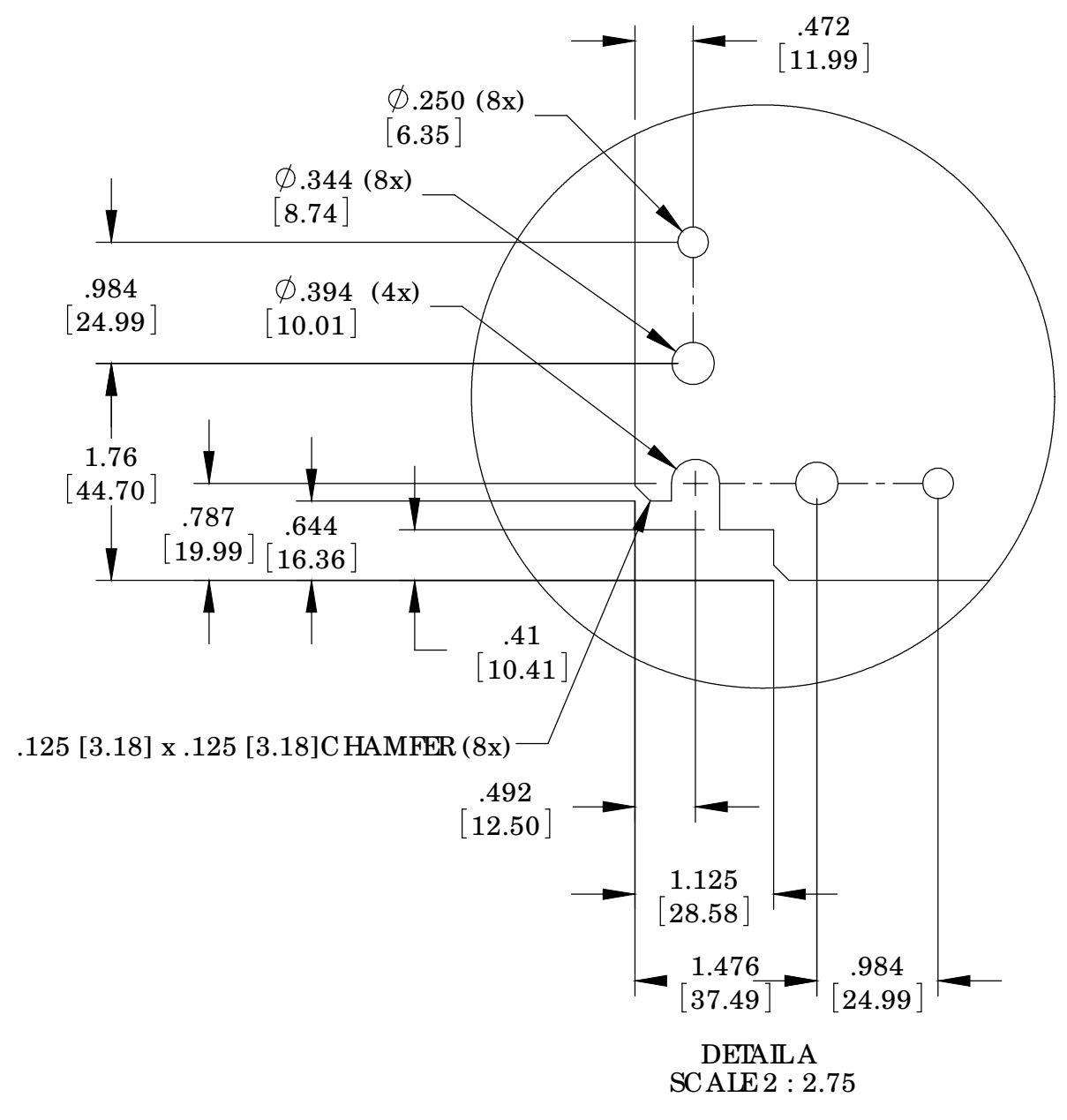
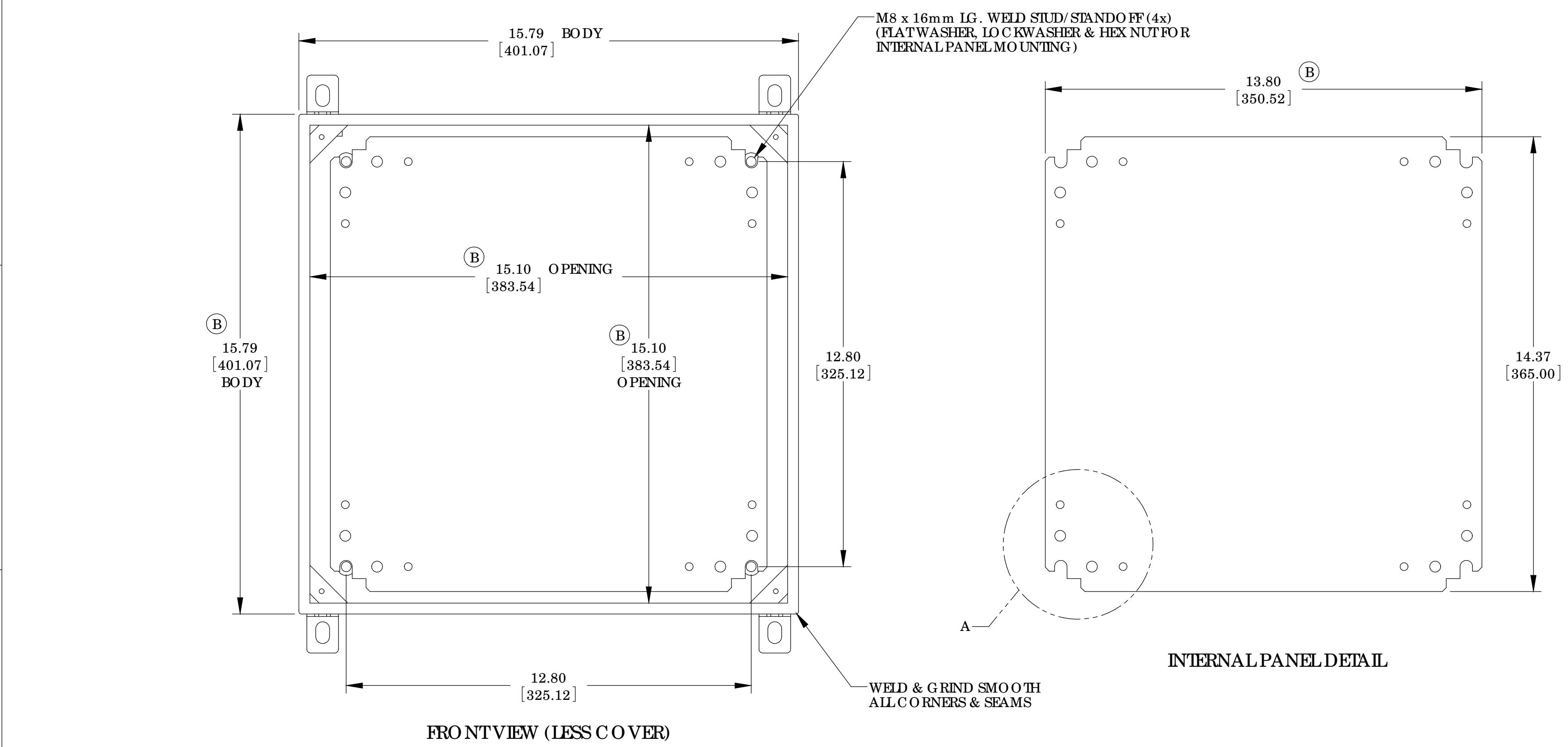
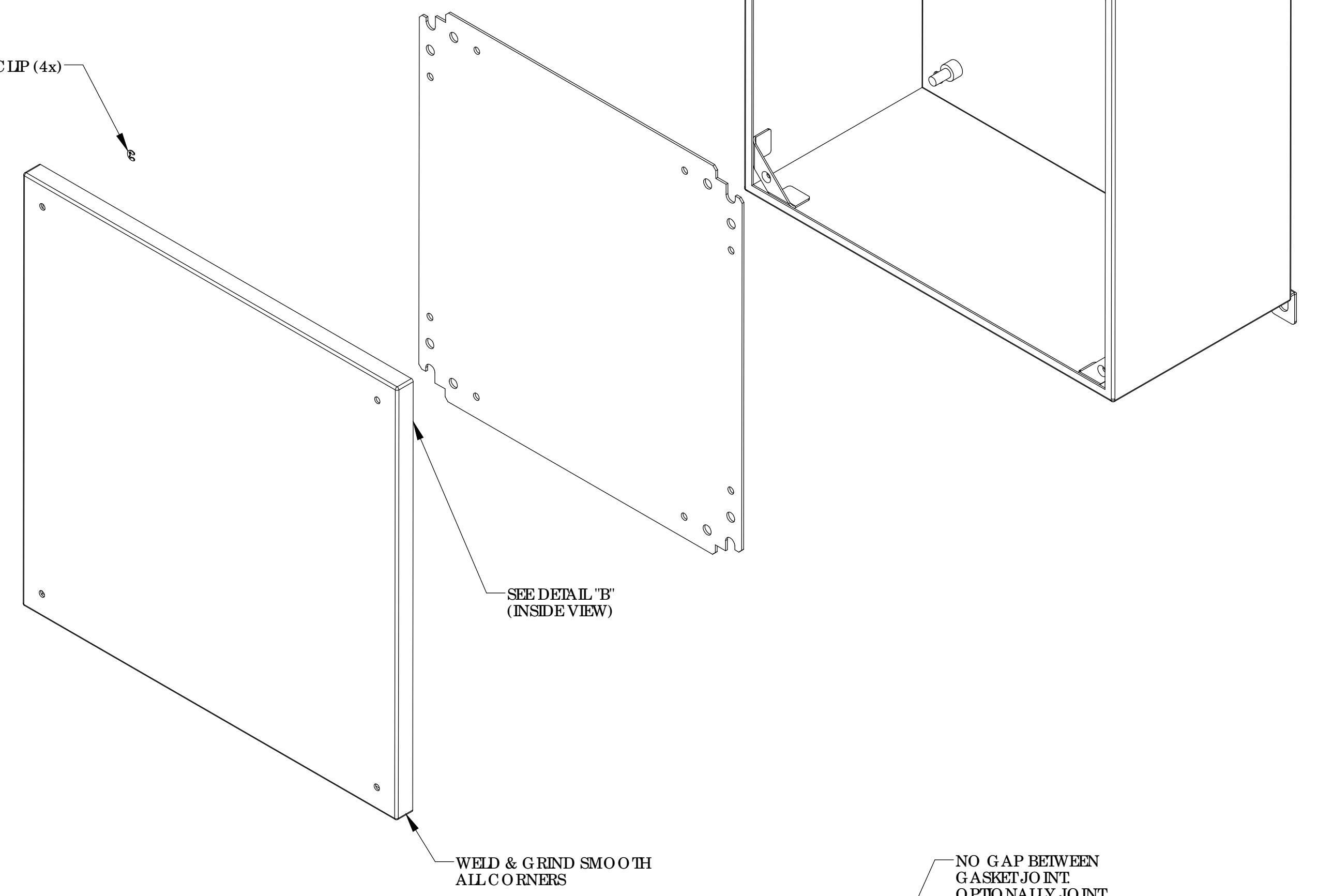
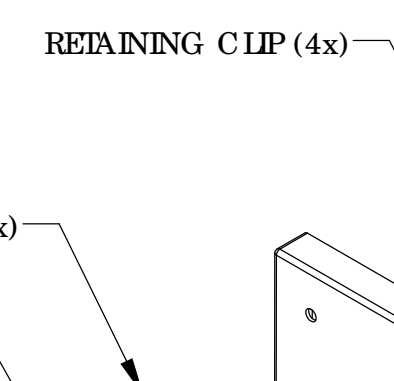

FRONT VIEW (LESS COVER)

INTERNAL PANEL DETAIL

DETAIL A SCALE 2 : 2.75

PARTS LIST		BUD INDUSTRIES INC.	
UNLESS OTHERWISE SPECIFIED ALL DIMENSIONS ARE IN INCHES	CAD GENERATED DRAWING DO NOT MANUALLY UPDATE		
FOR BRANCHES USE BRANCH NO. 1-100	APPROVALS DATE		
MATERIALS	DAB 5-5-08		
AS NOTED	APPROVED		

NEMA SHEET METAL BOX w/LIFT-OFF SCREW COVER

QTY	USED ON	DO NOT SCALE DRAWING	SCALE	CAD FILE	REV