



Chipsmall Limited consists of a professional team with an average of over 10 year of expertise in the distribution of electronic components. Based in Hongkong, we have already established firm and mutual-benefit business relationships with customers from,Europe,America and south Asia,supplying obsolete and hard-to-find components to meet their specific needs.

With the principle of “Quality Parts,Customers Priority,Honest Operation,and Considerate Service”,our business mainly focus on the distribution of electronic components. Line cards we deal with include Microchip,ALPS,ROHM,Xilinx,Pulse,ON,Everlight and Freescale. Main products comprise IC,Modules,Potentiometer,IC Socket,Relay,Connector.Our parts cover such applications as commercial,industrial, and automotives areas.

We are looking forward to setting up business relationship with you and hope to provide you with the best service and solution. Let us make a better world for our industry!



Contact us

Tel: +86-755-8981 8866 Fax: +86-755-8427 6832

Email & Skype: info@chipsmall.com Web: www.chipsmall.com

Address: A1208, Overseas Decoration Building, #122 Zhenhua RD., Futian, Shenzhen, China



DIMENSIONS ARE IN INCHES		UNLESS OTHERWISE NOTED TOLERANCES ARE:	
ONE PLACE DECIMALS ± .1[2.54]	THREE PLACE DECIMALS ± .005[.13]	ANGLES ± 1°	
TWO PLACE DECIMALS ± .01[.25]	FOUR PLACE DECIMALS ± .0020[.051]		

TITLE: .050 [1.27] X
 .100 [2.54] ⌀
 SHUNT ASSEMBLY

DWG NO: SNM-100-XX-X
 SHEET 1 OF 1

SNM-100-XX-X

BODY SPECIFICATION
 -100

PLATING SPECIFICATION
 -T = TIN: SPECIFY -T IN CONTACT SUFFIX -X
 -G = GOLD: SPECIFY -G IN CONTACT SUFFIX -X

COLOR SPECIFICATION
 SPECIFY COLOR IN BODY SUFFIX -XX
 BK = BLACK

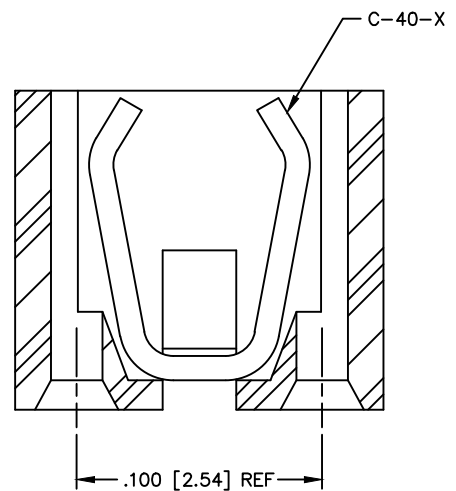
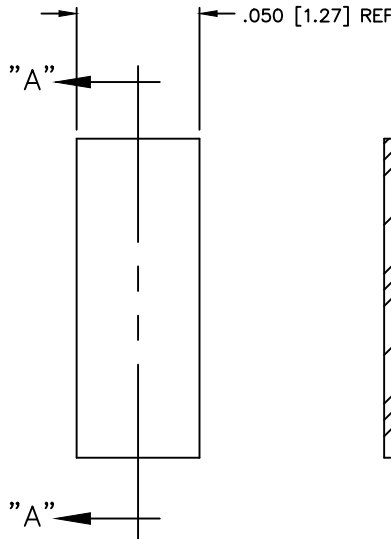
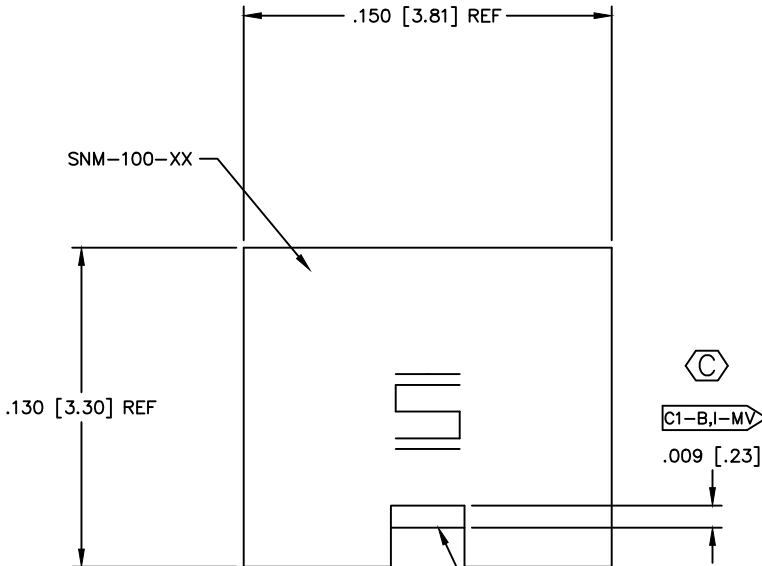

SECT "A-A"

RECOMMENDED
 POST ENTRY
 SEE NOTE 3

VISUAL, MUST BE ABLE TO SEE CONTACT
 MATERIAL THICKNESS IN THIS SECTION.

CRITICAL DIMENSION INSPECTION TABLE	
ASSEMBLY OPERATION	IN-PROCESS INSPECTION
FILL / BREAKOFF	C1

Do not scale
 from this print

- NOTES:
1. INSERTION FORCE USING (2) .018 SQ. PINS = 7 oz. AVG.
 2. WITHDRAWAL FORCE USING (2) .018 SQ. PINS = 3 oz. AVG.
 3. MINIMUM POST HEIGHT .135" [3.43] FOR PROPER MATE

PROPRIETARY NOTE
 THIS DOCUMENT CONTAINS INFORMATION
 CONFIDENTIAL AND PROPRIETARY TO
 SAMTEC INC. AND SHALL NOT BE
 REPRODUCED OR TRANSMITTED TO
 OTHER DOCUMENTS OR DISCLOSED TO
 OTHERS OR USED FOR ANY PURPOSE
 OTHER THAN THAT FOR WHICH IT WAS
 OBTAINED WITHOUT THE EXPRESSED
 WRITTEN CONSENT OF SAMTEC INC.

MATERIAL:
 BODY:
 VALOX DR-48
 COLOR: SPECIFIED IN PART NO.
 TERMINAL:
 PHOSPHOR BRONZE, CA510
 EXTRA HARD TEMPER

MISC\MKTG
 SNM-ASM

samtec

520 PARK EAST BLVD. NEW ALBANY, INDIANA 47150
 PHONE (812) 944-6733 P.O. BOX 1147
 CODE 55322

MADE BY: KOLB 7-20-89	ENG. APPROVAL	SNM-100-XX-X SHEET 1 OF 1
--------------------------	------------------	------------------------------