



Chipsmall Limited consists of a professional team with an average of over 10 year of expertise in the distribution of electronic components. Based in Hongkong, we have already established firm and mutual-benefit business relationships with customers from,Europe,America and south Asia,supplying obsolete and hard-to-find components to meet their specific needs.

With the principle of "Quality Parts,Customers Priority,Honest Operation,and Considerate Service",our business mainly focus on the distribution of electronic components. Line cards we deal with include Microchip,ALPS,ROHM,Xilinx,Pulse,ON,Everlight and Freescale. Main products comprise IC,Modules,Potentiometer,IC Socket,Relay,Connector.Our parts cover such applications as commercial,industrial, and automotives areas.

We are looking forward to setting up business relationship with you and hope to provide you with the best service and solution. Let us make a better world for our industry!



Contact us

Tel: +86-755-8981 8866 Fax: +86-755-8427 6832

Email & Skype: info@chipsmall.com Web: www.chipsmall.com

Address: A1208, Overseas Decoration Building, #122 Zhenhua RD., Futian, Shenzhen, China



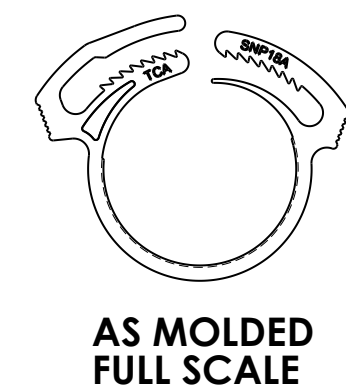
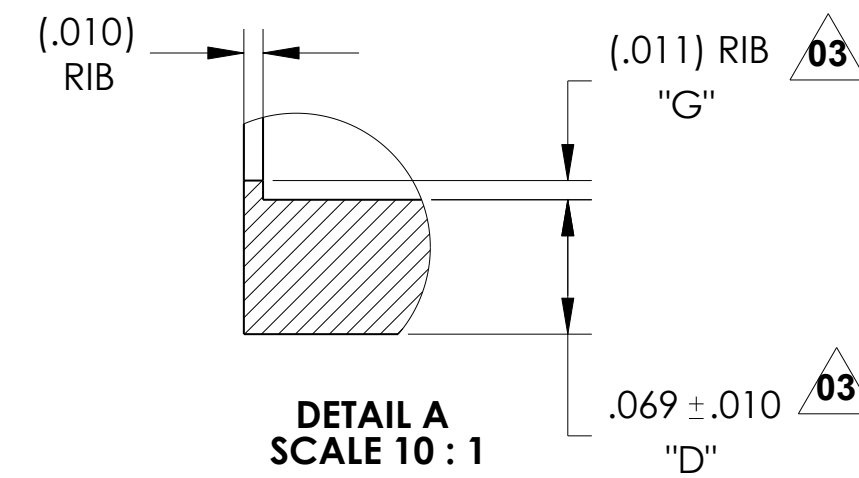
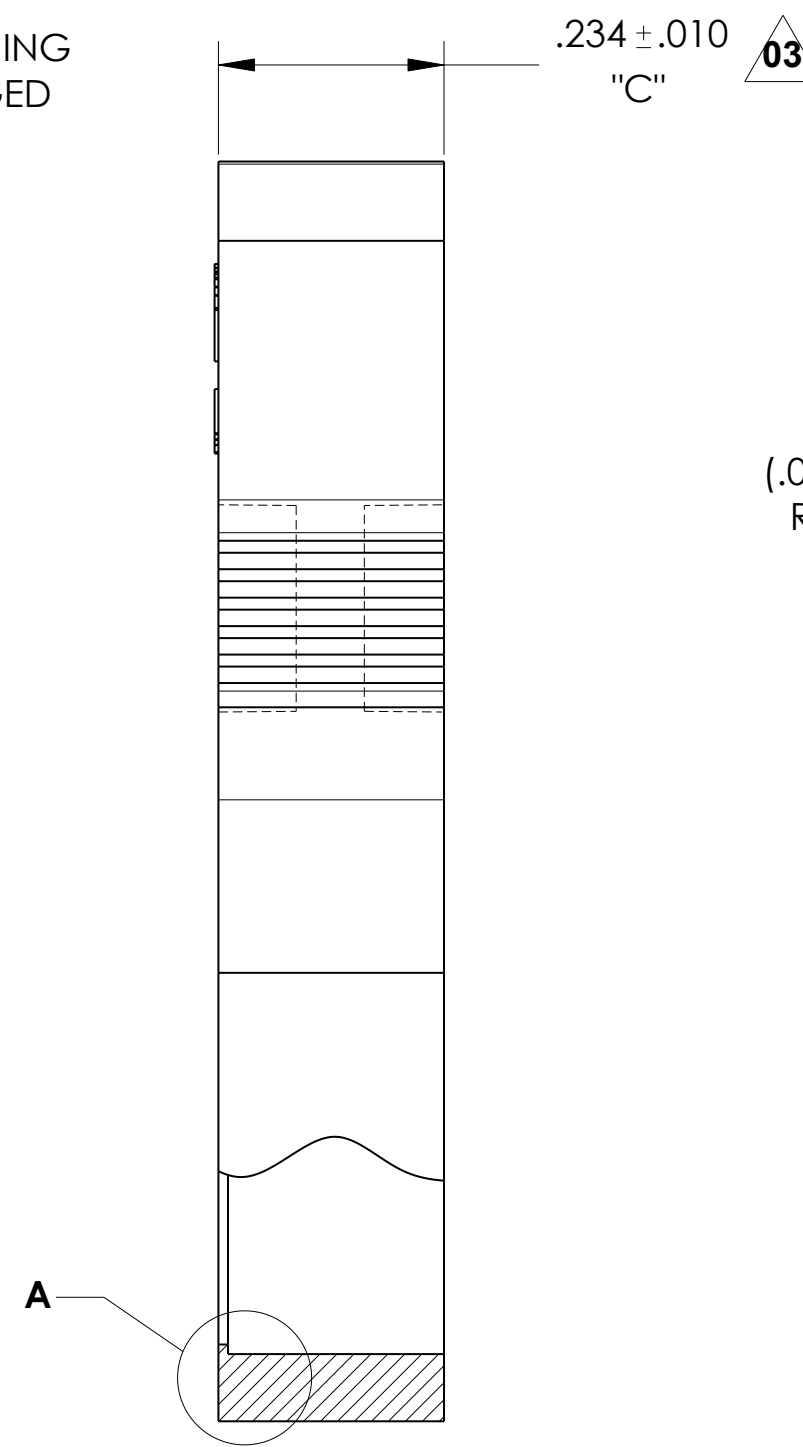
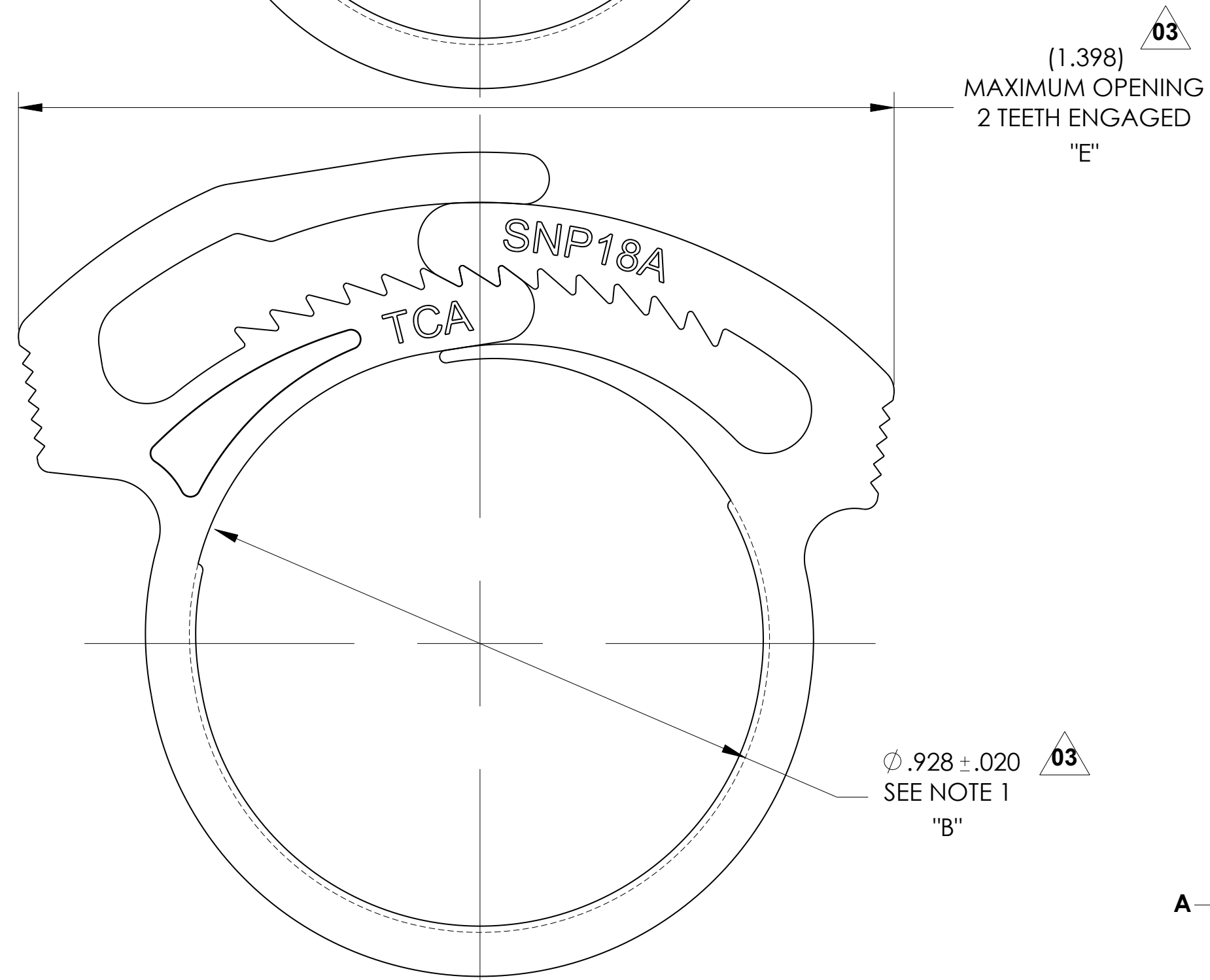
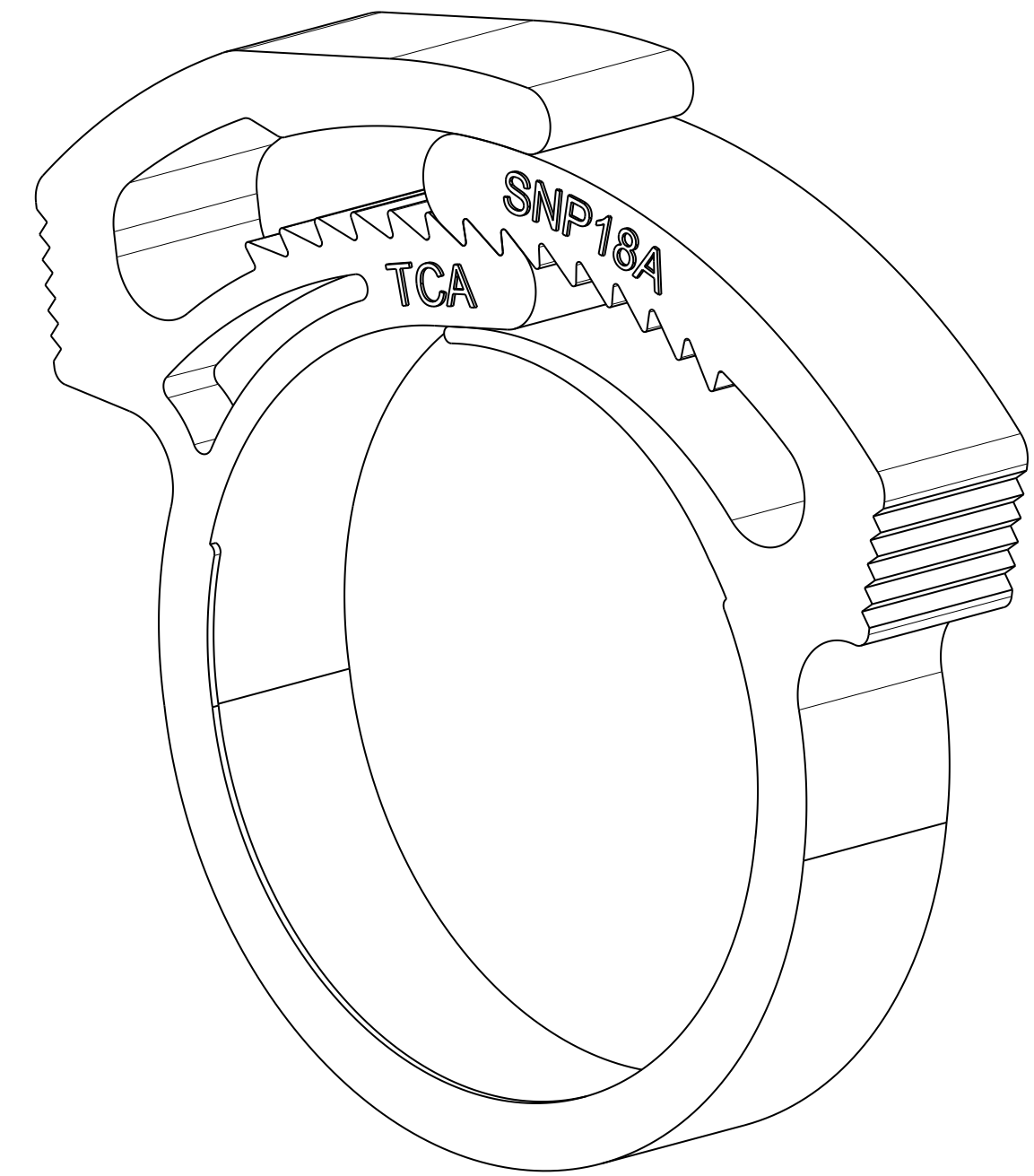
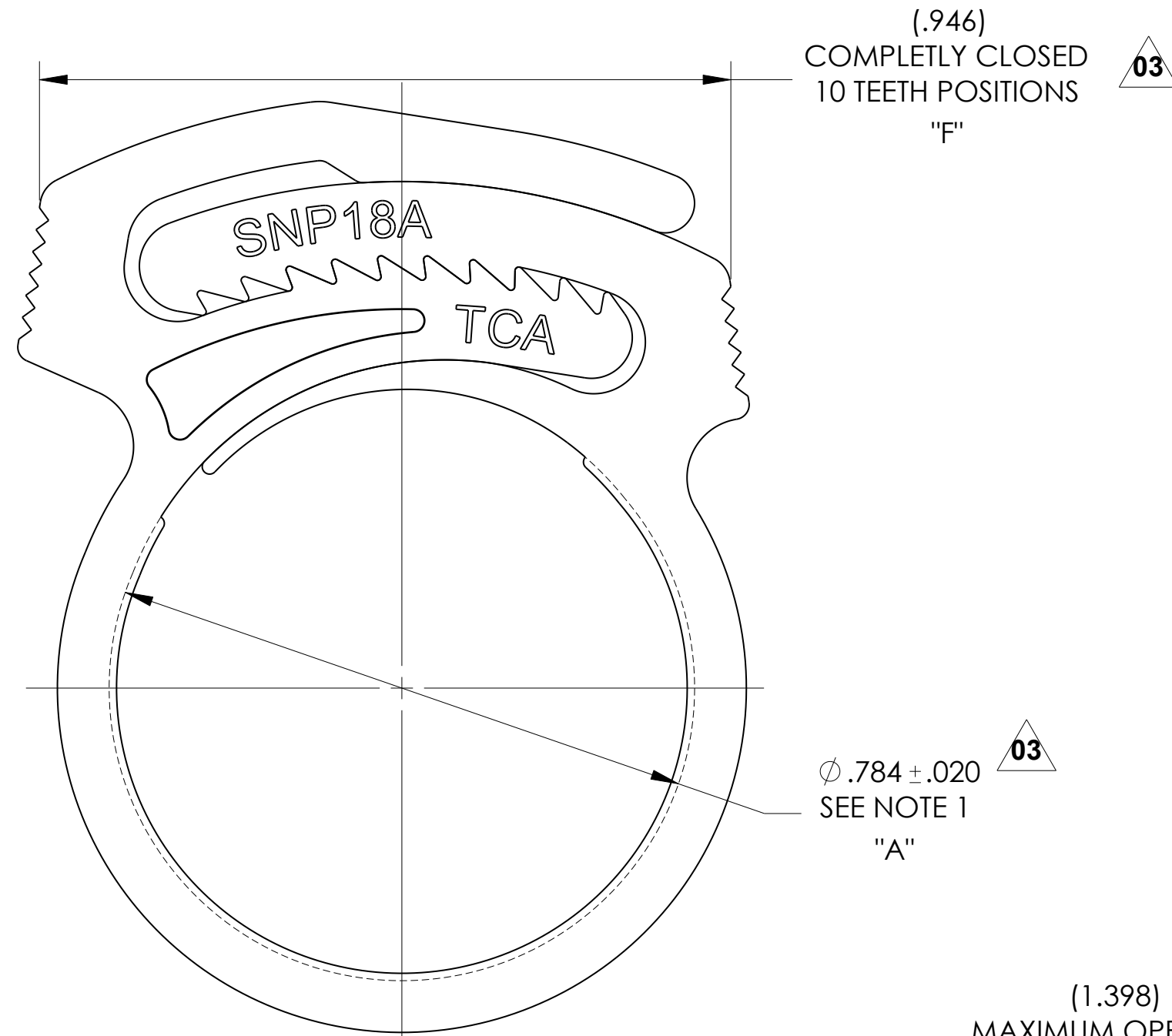

PRODUCT CODE DESCRIPTION

SNP18AGHS _____
 COLOR (CONSULT FACTORY FOR AVAILABLE COLORS)

HellermannTyton
 ALL PROPRIETARY RIGHTS IN THE SUBJECT MATTER SHOWN ON THIS DRAWING ARE EXCLUSIVE PROPERTY OF HELLERMANN TYTON

name	date	city, state

- NOTES**
- 1) INSIDE DIAMETERS ARE MEASURED IN THREE PLACES SPACED 120 DEGREES APART EXCLUDING RIB.
 - 2) 16 TOTAL TEETH, 10 TEETH POSITIONS.

REVISION

level	03
by	AAC
date	04/20/2006
ECN #	010409
part level	A

TOLERANCES

.XXXX	= ±.0005
.XXX	= ±.005
.XX	= ±.01
.X	= ±.03
∠	= ±0.5°
unless otherwise specified	
units	inches

PART

number	SNP18AGHS_	phase	Production
name			
SNP18A HOSE CLAMP			
material			
NYLON 6/6 13% GLASS FILLED; HEAT STABILIZED			

DRAWING

format	version	N	CAD	SW 2006	scale	5:1
computer file name	CP05-049-001CST_03			previous drawing number		
drawn	K.A.C.	checked	K.A.C.	approved		
date	08/03/2004	date	04/20/2006			
type	Customer	sheet 1 of 1				
number	CP05-049-001CST					