



Chipsmall Limited consists of a professional team with an average of over 10 year of expertise in the distribution of electronic components. Based in Hongkong, we have already established firm and mutual-benefit business relationships with customers from,Europe,America and south Asia,supplying obsolete and hard-to-find components to meet their specific needs.

With the principle of “Quality Parts,Customers Priority,Honest Operation,and Considerate Service”,our business mainly focus on the distribution of electronic components. Line cards we deal with include Microchip,ALPS,ROHM,Xilinx,Pulse,ON,Everlight and Freescale. Main products comprise IC,Modules,Potentiometer,IC Socket,Relay,Connector.Our parts cover such applications as commercial,industrial, and automotives areas.

We are looking forward to setting up business relationship with you and hope to provide you with the best service and solution. Let us make a better world for our industry!



Contact us

Tel: +86-755-8981 8866 Fax: +86-755-8427 6832

Email & Skype: info@chipsmall.com Web: www.chipsmall.com

Address: A1208, Overseas Decoration Building, #122 Zhenhua RD., Futian, Shenzhen, China





soberton inc.

SP DYNAMIC SPEAKER UNIT

Acoustic Product Specification

Product Number: SP-1303L-3

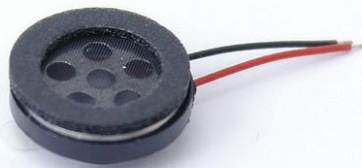

Release | Revision: B/2018

CONTENTS

This document contains the technical specifications for the dynamic speaker unit for mobile telephones.

Page 1
Speaker Electroacoustic Characteristics

General Specifications

Page 2
Reliability Tests

Page 3
Measuring Method (Speaker Mode)

Standard Test Condition of Speakers

Page 4
Frequency Response Curve

Page 5
Dimensions

Page 6
Packing

Dynamic Speaker Electroacoustic Characteristics

Sound Pressure Level

87±3dB SPL @1.0, 1.2,1.5 and 2.0KHz in average (0dB SPL=20µPa)
Measuring Condition: 0.1W (Sine wave) 10cm measured with baffler shown in Fig.1.

Frequency Response Curve

As shown in Figure 2

Response Frequency

1100±20%Hz @ 1V. (Without Baffler)

Input Power (Nominal and Maximum)

Rated Noise Power 0.5W

Short Term Max Power: 0.8W must be normal at a white noise (1W, F0 ~ 20KHz) for one minute

Operation Test

Must be free audible noise (buzzes and rattles)

(300 ~ 8KHz frequency range, input level up to 2.0 Vrms)

Distortion

Less than 10% @1KHz, 0.1M, 0.1W frequency range, input level up to 0.1W

General Specifications

Operating Temperature Range

-20°C~+60°C

Storage Temperature Range

-30°C~+65°C

Standard Test Conditions

Temperature 17°C~25°C

Relative Humidity 45%~80%(RH)

AC Impedance

8±15%Ω (@2KHz 1V) without baffler

Dimension

Ø13.0x5.1mm WIRE (15mm)

IP Level

IP50



soberton inc.

SP DYNAMIC SPEAKER UNIT

Acoustic Product Specification

Product Number: SP-1303L-3

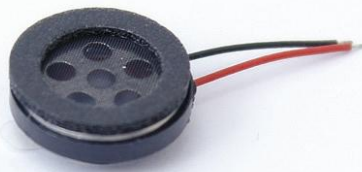

Release | Revision: B/2018

CONTENTS

This document contains the technical specifications for the dynamic speaker unit for mobile telephones.

Page 1

Speaker Electroacoustic Characteristics

General Specifications

Page 2

Reliability Tests

Page 3

Measuring Method (Speaker Mode)

Standard Test Condition of Speakers

Page 4

Frequency Response Curve

Page 5

Dimensions

Page 6

Packing

Reliability Tests

The sound pressure as specified will neither deviate more than $\pm 3\text{dB}$ from the initial value, nor have any significant damage after any of following testing.

High Temperature Test

High Temperature $+60\pm 2^\circ\text{C}$

Duration 96 hours

Low Temperature Test

Low Temperature $-20\pm 2^\circ\text{C}$

Duration 96 hours

Heat Shock Test

High Temperature $+60\pm 2^\circ\text{C}$

Low Temperature $-20\pm 2^\circ\text{C}$

Changeover Time < 30 seconds

Duration 1 hour

Cycle 100

Humidity Test

Temperature $+ 40\pm 2^\circ\text{C}$

Relative Humidity 90%~95%

Duration 96 hours

Temperature Cycle Test

Temperature -20°C $+60^\circ\text{C}$

Duration 45 minutes 45 minutes

Temperature gradient $1\sim 3^\circ\text{C}/\text{min}$

Cycle 25

Drop Test

Mounted with dummy set mass 100 g

Height 1.5 m

Cycle 6 (1 each plain) onto the concrete board

Load Test

Speaker mode: White noise (EIA filter) for 96 hours @ 0.5W input power.



soberton inc.

SP DYNAMIC SPEAKER UNIT

Acoustic Product Specification

Product Number: SP-1303L-3

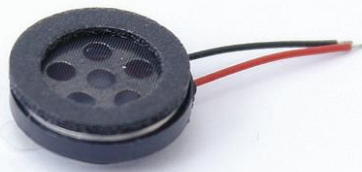

Release | Revision: B/2018

CONTENTS

This document contains the technical specifications for the dynamic speaker unit for mobile telephones.

Page 1
Speaker Electroacoustic Characteristics

General Specifications

Page 2
Reliability Tests

Page 3
Measuring Method (Speaker Mode)

Standard Test Condition of Speakers

Page 4
Frequency Response Curve

Page 5
Dimensions

Page 6
Packing

Measuring Method (Speaker Mode)

Standard Test Condition

Temperature 15 ~ 35°C

Relative humidity 45% ~ 85%

Atmospheric pressure 860mbar to 1060mbar

Standard Test Fixture

Input Power 0.1W

Zero Level -dB

Mode TSR

Potentiometer Range 50dB

Sweep Time 0.5sec

Standard Test Condition of Speaker (Fig. 1)

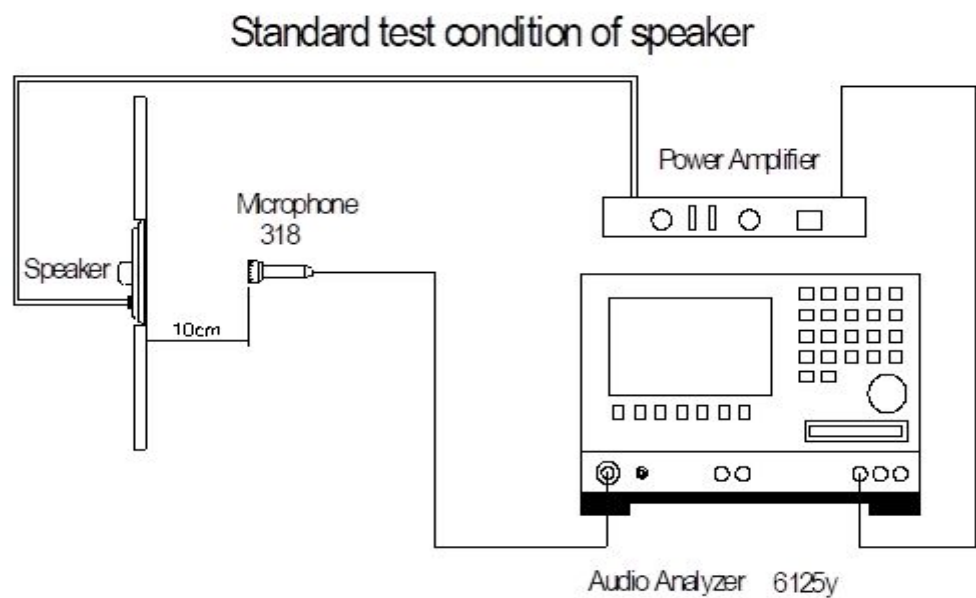



soberton inc.

SP DYNAMIC SPEAKER UNIT

Acoustic Product Specification

Product Number: SP-1303L-3

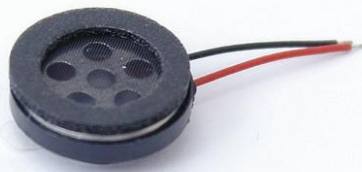

Release | Revision: B/2018

CONTENTS

This document contains the technical specifications for the dynamic speaker unit for mobile telephones.

Page 1

Speaker Electroacoustic Characteristics

General Specifications

Page 2

Reliability Tests

Page 3

Measuring Method (Speaker Mode)

Standard Test Condition of Speakers

Page 4

Frequency Response Curve

Page 5

Dimensions

Page 6

Packing

Frequency Response Curve (Fig. 2)

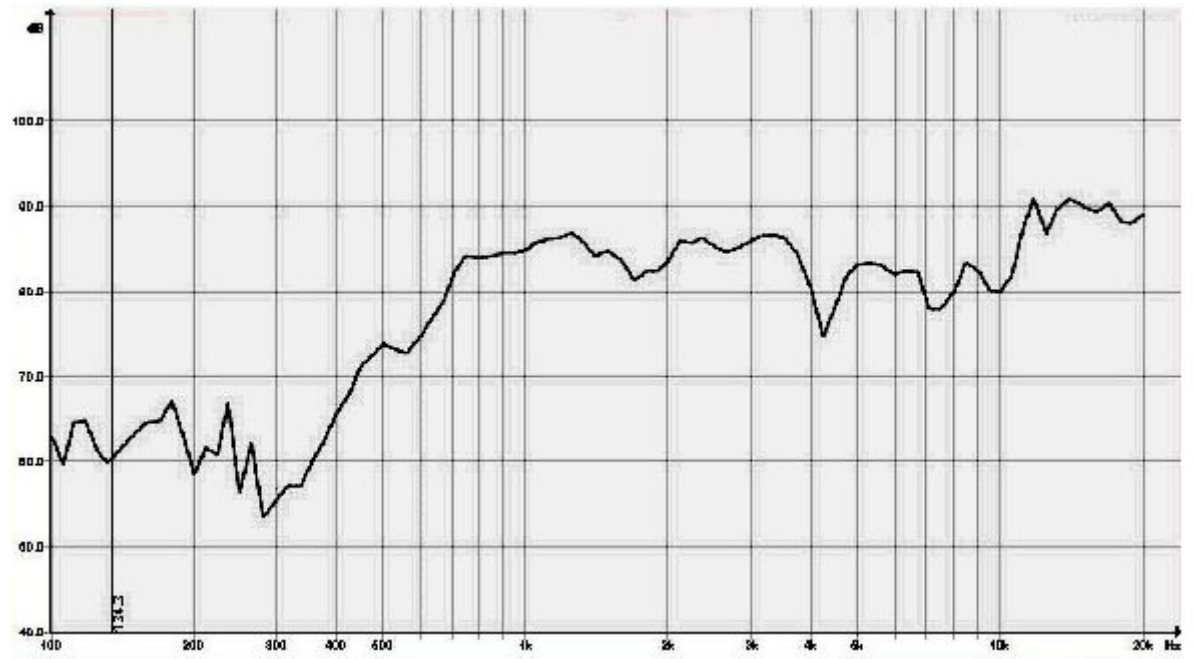



soberton inc.

SP DYNAMIC SPEAKER UNIT

Acoustic Product Specification

Product Number: SP-1303L-3



Release | Revision: B/2018

CONTENTS

This document contains the technical specifications for the dynamic speaker unit for mobile telephones.

Page 1
Speaker Electroacoustic Characteristics

General Specifications

Page 2
Reliability Tests

Page 3
Measuring Method (Speaker Mode)

Standard Test Condition of Speakers

Page 4
Frequency Response Curve

Page 5
Dimensions

Page 6
Packing

Dimensions

Tolerance: ± 0.5 (unit: mm)

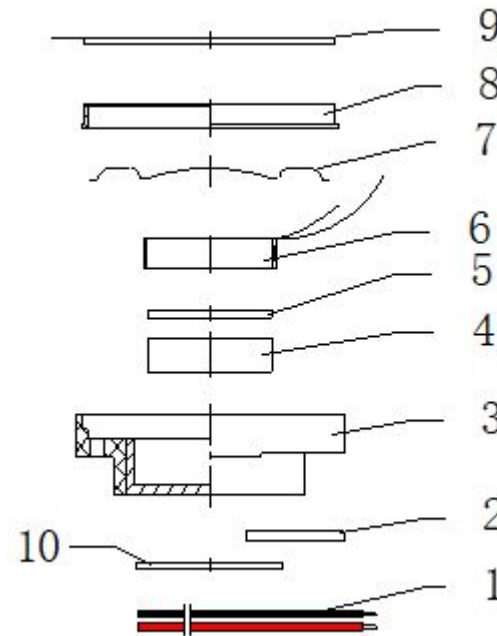
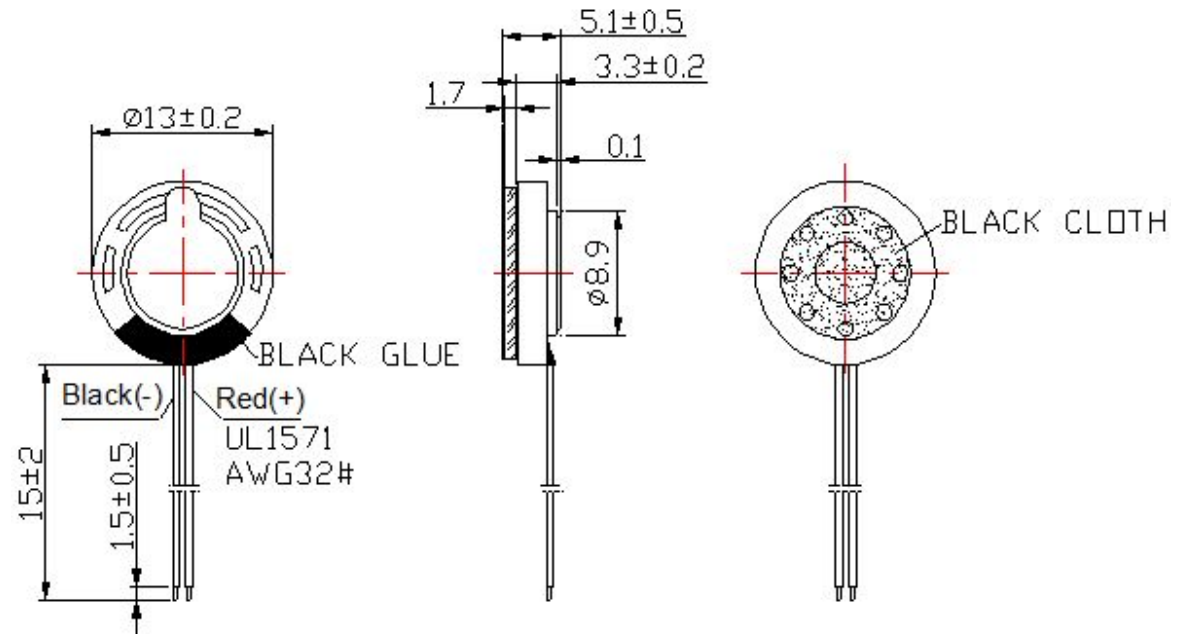

No.	Part Name	Material	Quantity
1	Wire	UL1571 AWG32#	2
2	PCB	FR-4	1
3	Frame	PBT	1
4	Magnet	Nd Fe B	1
5	Plate	SPCC	1
6	Voice Coil	Polyurethane Enamelled Wire	1
7	Diaphragm	PET	1
8	Cap	SUS 304	1
9	Gasket	Black Cloth	1
10	Cushion Tape	Adhesive	1



soberton inc.

SP DYNAMIC SPEAKER UNIT

Acoustic Product Specification

Product Number: SP-1303L-3

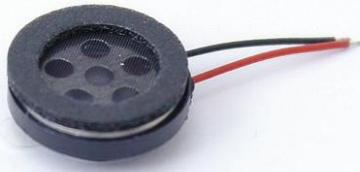

Release | Revision: B/2018

CONTENTS

This document contains the technical specifications for the dynamic speaker unit for mobile telephones.

Page 1
Speaker Electroacoustic Characteristics

General Specifications

Page 2
Reliability Tests

Page 3
Measuring Method (Speaker Mode)

Standard Test Condition of Speakers

Page 4
Frequency Response Curve

Page 5
Dimensions

Page 6
Packing

Packing

