



Chipsmall Limited consists of a professional team with an average of over 10 year of expertise in the distribution of electronic components. Based in Hongkong, we have already established firm and mutual-benefit business relationships with customers from,Europe,America and south Asia,supplying obsolete and hard-to-find components to meet their specific needs.

With the principle of “Quality Parts,Customers Priority,Honest Operation,and Considerate Service”,our business mainly focus on the distribution of electronic components. Line cards we deal with include Microchip,ALPS,ROHM,Xilinx,Pulse,ON,Everlight and Freescale. Main products comprise IC,Modules,Potentiometer,IC Socket,Relay,Connector.Our parts cover such applications as commercial,industrial, and automotives areas.

We are looking forward to setting up business relationship with you and hope to provide you with the best service and solution. Let us make a better world for our industry!



Contact us

Tel: +86-755-8981 8866 Fax: +86-755-8427 6832

Email & Skype: info@chipsmall.com Web: www.chipsmall.com

Address: A1208, Overseas Decoration Building, #122 Zhenhua RD., Futian, Shenzhen, China





MODEL: SP-1304
PRODUCT: Dynamic Speaker
EDITION: A/2016

THIS SPECIFICATION COVERS OUR PRODUCT OF DYNAMIC SPEAKER UNIT FOR MOBILE PHONE USE

DYNAMIC SPEAKER ELECTORACOUSTIC CHARACTERISTICS

sound pressure level	88±3dB SPL @0.8, 1.0, 1.5 and 2.0KHz in average (0dB SPL=20µPa)
measuring condition	0.1W(Sine wave) 10cm measured with baffler shown in Fig.1
frequency response curve	As shown in Fig.2
response frequency	900±20%Hz @ 1V. (without baffler)
rated noise power	0.2W
short-term max. power	0.3W must be normal at a white noise (1W, F0-20KHz) for 1 minute
distortion	Less than 10% @1KHz, 0.1M, 0.2W frequency range, input level up to 2.53Vrms
operation test	Must be free audible noise (buzzes and rattles) 300 ~ 8KHz frequency range, input level up to 2.53Vrms

GENERAL SPECIFICATIONS

operating temperature range	-20°C ~ +60°C
standard test conditions	
temperature	17°C ~ 25°C
relative humidity	45% ~ 80%(RH)
ac impedance	32±15%Ω (@2KHz 1V) without baffler
dc resistance	30±15%Ω
dimensions	Ø13.0*4.3

MEASURING METHOD (SPEAKER MODE) (Figure 1)

Standard test condition of speaker

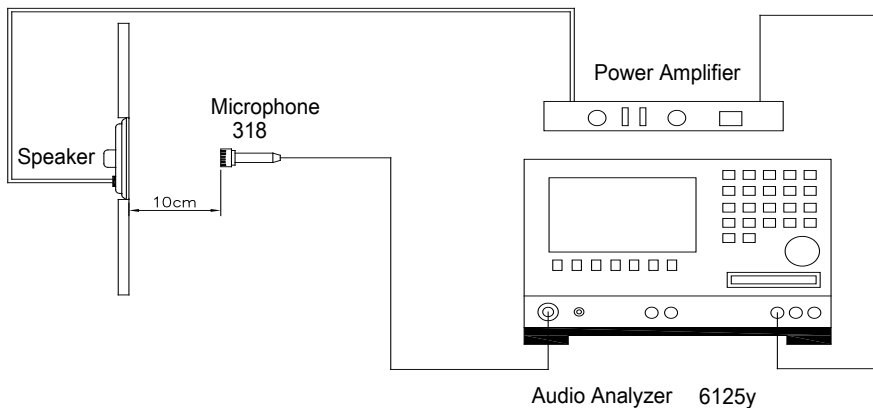

TEST CONDITION	
STANDARD	
temperature	15 ~ 35°C
relative humidity	45% ~ 85%
atmospheric pressure	860mbar to 1060mbar.
STANDARD TEST FIXTURE	
input power	0.1W (1.789V)
zero level	-dB
mode	TSR
potentiometer range	50dB
sweep time	0.5sec



MODEL: SP-1304
PRODUCT: Dynamic Speaker
EDITION: A/2016

Soberton Inc.

TYPICAL FREQUENCY RESPONSE CURVE (Figure 2)

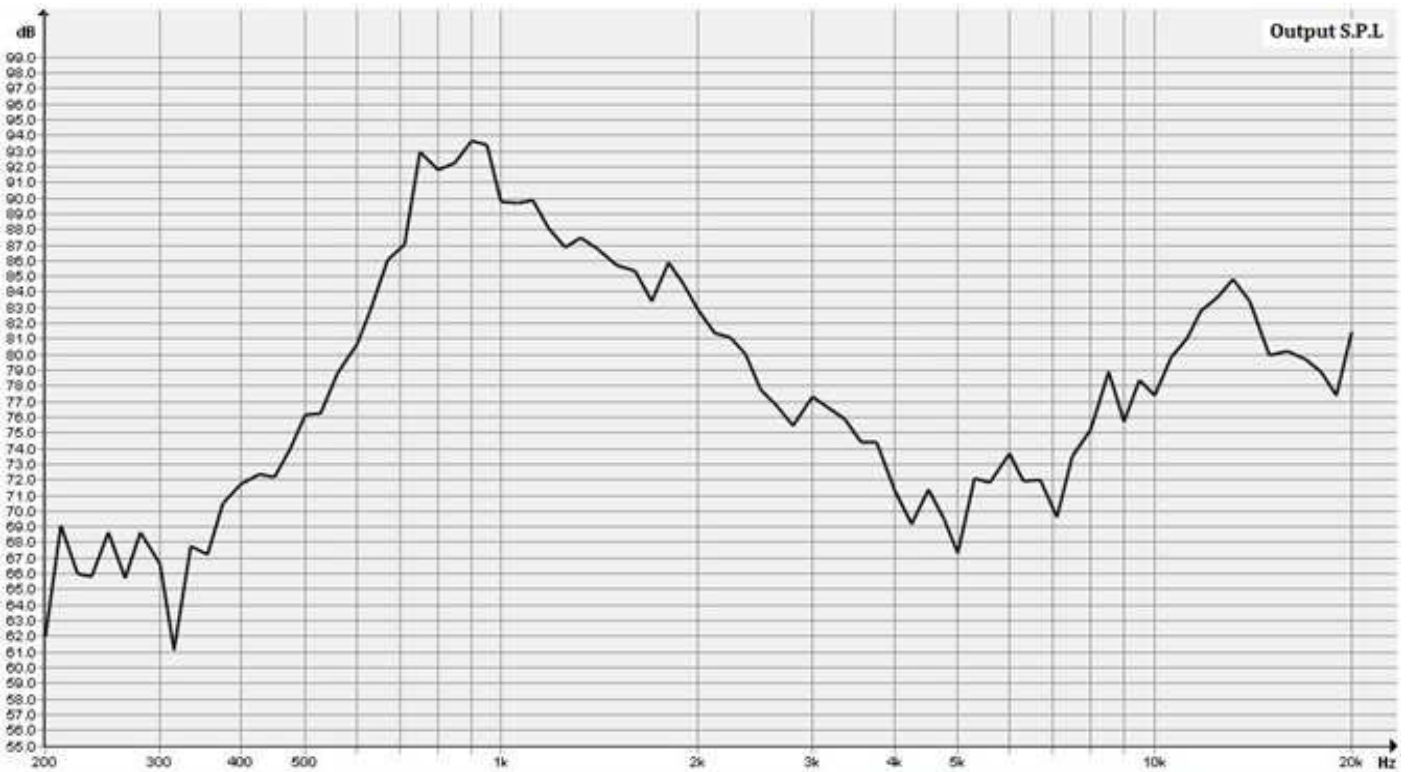



MODEL: SP-1304
PRODUCT: Dynamic Speaker
EDITION: A/2016

RELIABILITY TESTS

The sound pressure as specified shall neither deviate more than $\pm 3\text{dB}$ from the initial value, nor have any significant damage after any of following testing.

HIGH TEMPERATURE TEST

high temperature	$+60\pm 2^\circ\text{C}$
duration	96 hours

LOW TEMPERATURE TEST

low temperature	$-20\pm 2^\circ\text{C}$
duration	96 hours

HEAT SHOCK TEST

high temperature	$+60\pm 2^\circ\text{C}$
low temperature	$-20\pm 2^\circ\text{C}$
duration	1 hour
changeover time	< 30 seconds
cycle	100

HUMIDITY TEST

temperature	$+40\pm 2^\circ\text{C}$
relative humidity	90~95%
duration	96 hours

TEMPERATURE CYCLE TEST

temperature	-20°C	$+60^\circ\text{C}$
duration	45 minutes	45 minutes
temperature gradient	1~3°C/min.	
cycle	25	

DROP TEST

mounted with dummy set mass	100 g
height	1.5 m
cycle	6 (1 each plain) onto the concrete board

LOAD TEST

noise signal	White noise (EIA filter)
input power	0.2W
duration	96 hours



MODEL: SP-1304
PRODUCT: Dynamic Speaker
EDITION: A/2016

DIMENSIONS

Tolerance: ± 0.5 (unit: mm)

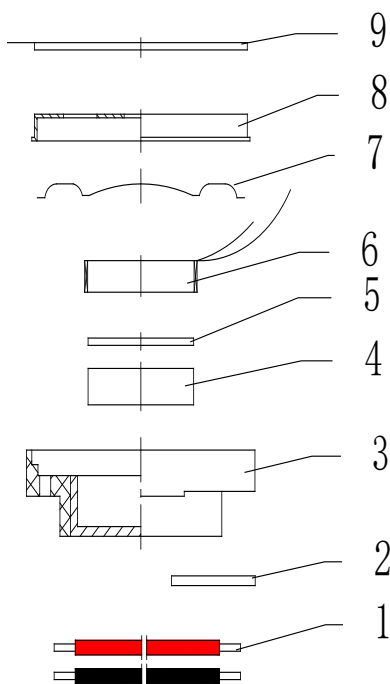
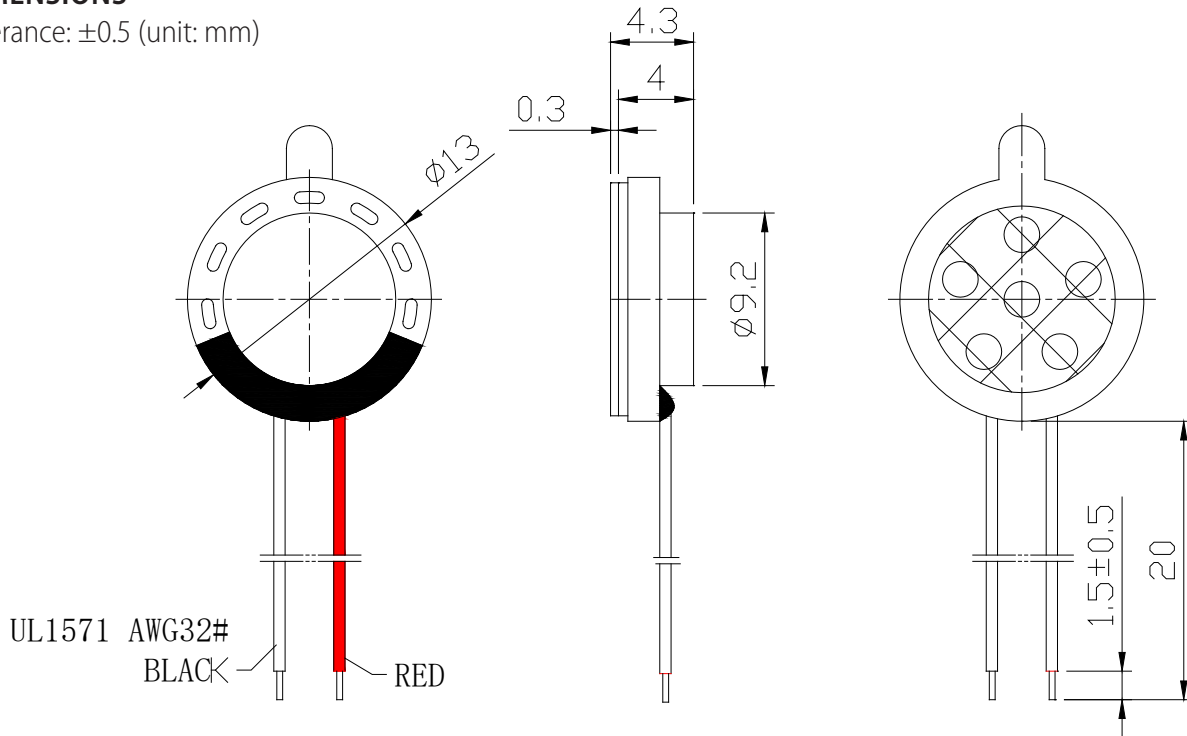

no	item	material	quantity
1	UL1571 AWG32#	Wire Red/Black	2
2	PCB	Epoxy glass fiber + Copper	1
3	Frame	PBT	1
4	Magnet	ND Fe B-N38	1
5	Plate	SPCC	1
6	Voice Coil	Copper	1
7	Membrane	PEN	1
8	Cap	SUS 304	1
9	Gasket	Polyester fiber	1



MODEL: SP-1304
PRODUCT: Dynamic Speaker
EDITION: A/2016

PACKING

100PCS×10=1000PCS

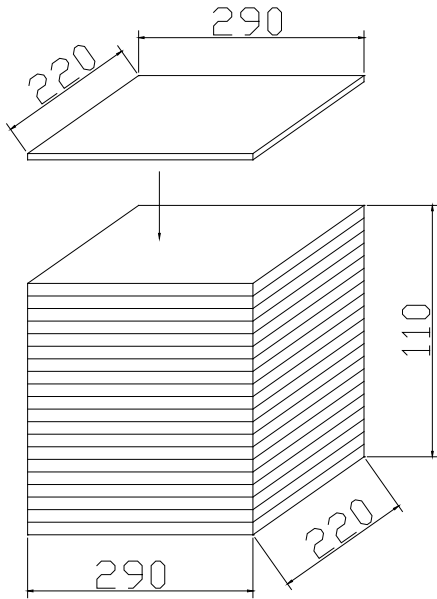

1000PCS×5=5000PCS

