



Chipsmall Limited consists of a professional team with an average of over 10 year of expertise in the distribution of electronic components. Based in Hongkong, we have already established firm and mutual-benefit business relationships with customers from,Europe,America and south Asia,supplying obsolete and hard-to-find components to meet their specific needs.

With the principle of “Quality Parts,Customers Priority,Honest Operation,and Considerate Service”,our business mainly focus on the distribution of electronic components. Line cards we deal with include Microchip,ALPS,ROHM,Xilinx,Pulse,ON,Everlight and Freescale. Main products comprise IC,Modules,Potentiometer,IC Socket,Relay,Connector.Our parts cover such applications as commercial,industrial, and automotives areas.

We are looking forward to setting up business relationship with you and hope to provide you with the best service and solution. Let us make a better world for our industry!



## Contact us

Tel: +86-755-8981 8866 Fax: +86-755-8427 6832

Email & Skype: info@chipsmall.com Web: www.chipsmall.com

Address: A1208, Overseas Decoration Building, #122 Zhenhua RD., Futian, Shenzhen, China



Ultra Low Capacitance Discrete TVS Series

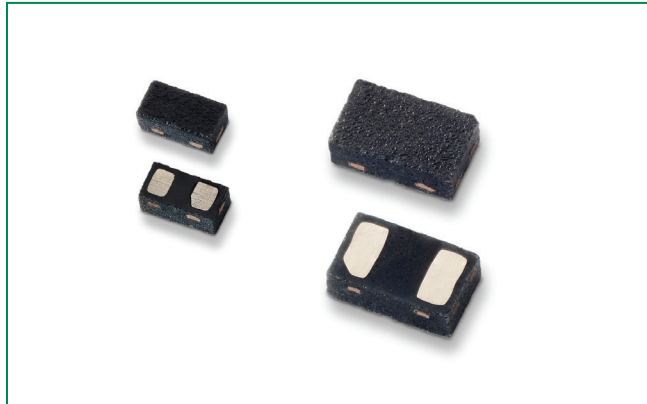

**Pinout**

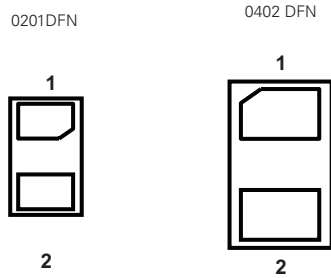

Bottom View

**Functional Block Diagram**

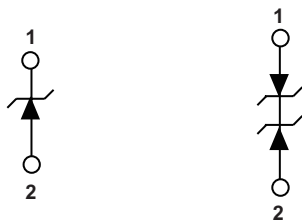

Unidirectional

Bidirectional

**Description**

The Ultra Low Capacitance Discrete TVS series provides unidirectional and bidirectional ESD protection for the world's most challenging high speed serial interfaces. Ultra low capacitance permits excellent signal integrity on the most challenging consumer electronics interfaces, such as USB 3.1, HDMI 2.0, DisplayPort, and V-by-One®. Providing in excess of 20kV contact ESD protection (IEC61000-4-2) while maintaining extremely low leakage and dynamic resistance, offered in the industry's most popular footprints (0402 and 0201), the series sets higher standards for signal integrity and usability.

**Features**

- 0.13pF MAX bidirectional
- 0.25pF MAX unidirectional
- ESD, IEC61000-4-2, ±20kV contact, ±20kV air
- Low clamping voltage of 10V @  $I_{pp}=2A$  (Bidirectional) ( $t_p=8/20\mu s$ )
- Low profile 0201 and 0402 DFN packages
- Facilitates excellent signal integrity
- ELV Compliant
- Halogen free, Lead free and RoHS compliant

**Applications**

- Ultra-high speed data lines
- USB 3.1, 3.0, 2.0
- HDMI 2.0, 1.4a, 1.3
- DisplayPort™
- Thunderbolt (Light Peak)
- V-by-One®
- LVDS interfaces
- Consumer, mobile and portable electronics
- Tablet PC and external storage with high speed interfaces
- Applications requiring high ESD performance in small packages

### Absolute Maximum Ratings

Symbol	Parameter	Value	Units
$I_{PP}$	Peak Current ( $t_p=8/20\mu s$ )	2.0	A
$T_{OP}$	Operating Temperature	-30 to 85	°C
$T_{STOR}$	Storage Temperature	-55 to 150	°C

CAUTION: Stresses above those listed in "Absolute Maximum Ratings" may cause permanent damage to the device. This is a stress only rating and operation of the device at these or any other conditions above those indicated in the operational sections of this specification is not implied.

### Thermal Information

Parameter	Rating	Units
Storage Temperature Range	-55 to 150	°C
Maximum Junction Temperature	150	°C
Maximum Lead Temperature (Soldering 20-40s)	260	°C

### Unidirectional Electrical Characteristics - ( $T_{OP}=25^\circ C$ )

Parameter	Test Conditions	Min	Typ	Max	Units
Input Capacitance	@ $V_R = 0V$ , $f = 3GHz$		0.20	0.25	pF
Breakdown Voltage	$V_{BR}$ @ $I_T=1mA$		9.00		V
Reverse Working Voltage				7.0	V
Reverse Leakage Current	$I_L$ @ $V_{RWM}=5.0V$		25	50	nA
Clamping Voltage	$V_{CL}$ @ $I_{PP}=2.0A$		9.20		V
ESD Withstand Voltage	IEC61000-4-2 (Contact)	±20			kV
	IEC61000-4-2 (Air)	±20			

### Bidirectional Electrical Characteristics - ( $T_{OP}=25^\circ C$ )

Parameter	Test Conditions	Min	Typ	Max	Units
Input Capacitance	@ $V_R = 0V$ , $f = 3GHz$		0.10	0.13	pF
Breakdown Voltage	$V_{BR}$ @ $I_T=1mA$		9.80		V
Reverse Working Voltage		-7.0		7.0	V
Reverse Leakage Current	$I_L$ @ $V_{RWM}=5.0V$		25	50	nA
Clamping Voltage	$V_{CL}$ @ $I_{PP}=2.0A$		10.0		V
ESD Withstand Voltage	IEC61000-4-2 (Contact)	±20			kV
	IEC61000-4-2 (Air)	±20			

### Insertion Loss Diagram - Unidirectional

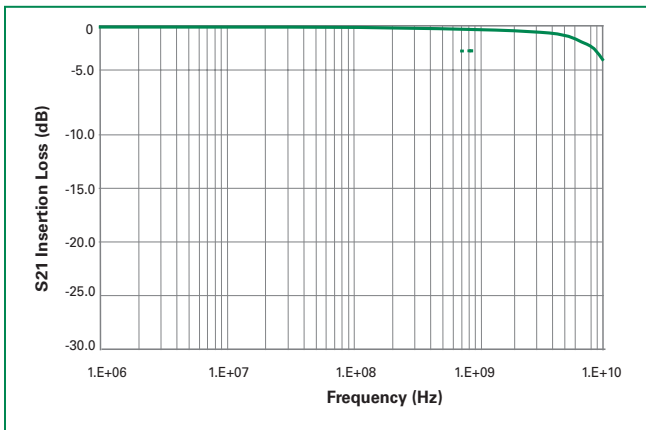

### Insertion Loss Diagram - Bidirectional

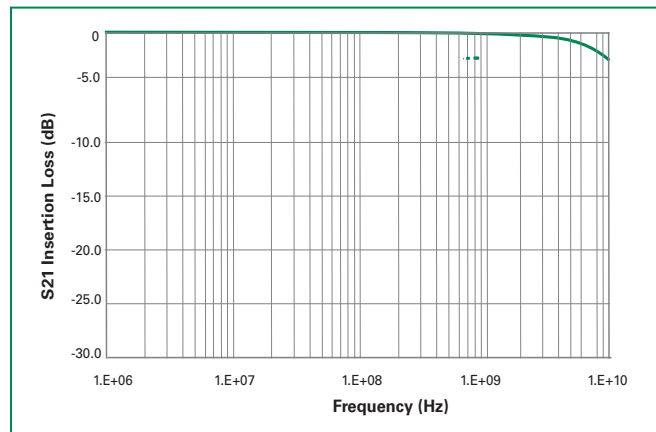

### Device IV Curve - Unidirectional

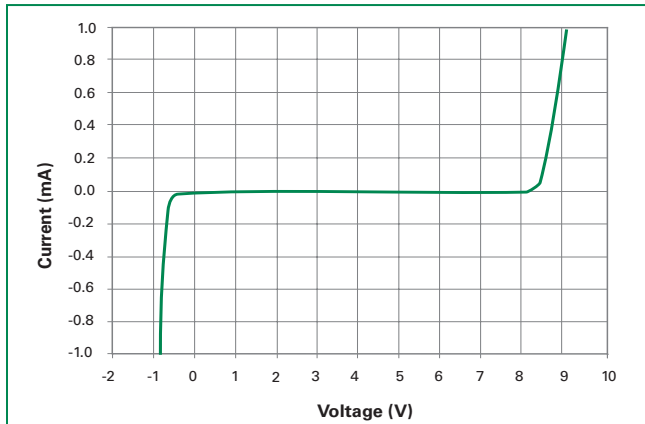

### Device IV Curve - Bidirectional

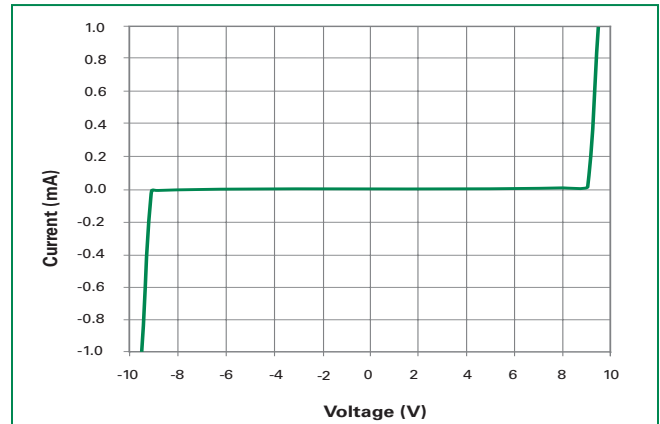

### USB3.0 Eye Diagram

5.0 Gb/s, 1000mV differential, CPO Compliant Test Pattern

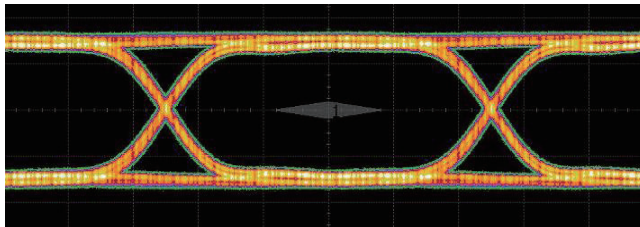

Without Device

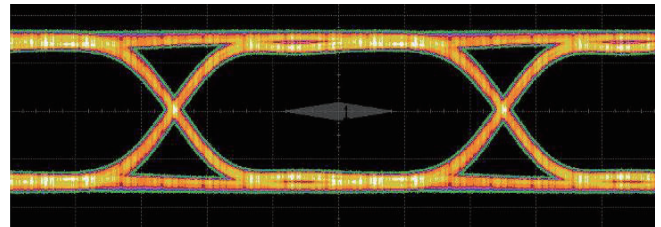

With Device

### Soldering Parameters

Reflow Condition		Pb – Free assembly
Pre Heat	- Temperature Min ( $T_{s(min)}$ )	150°C
	- Temperature Max ( $T_{s(max)}$ )	200°C
	- Time (min to max) ( $t_s$ )	60 – 180 secs
Average ramp up rate (Liquidus) Temp ( $T_L$ ) to peak		3°C/second max
$T_{s(max)}$ to $T_L$ - Ramp-up Rate		3°C/second max
Reflow	- Temperature ( $T_L$ ) (Liquidus)	217°C
	- Temperature ( $t_L$ )	60 – 150 seconds
Peak Temperature ( $T_p$ )		260 <sup>+0/-5</sup> °C
Time within 5°C of actual peak Temperature ( $t_p$ )		20 – 40 seconds
Ramp-down Rate		6°C/second max
Time 25°C to peak Temperature ( $T_p$ )		8 minutes Max.
Do not exceed		260°C

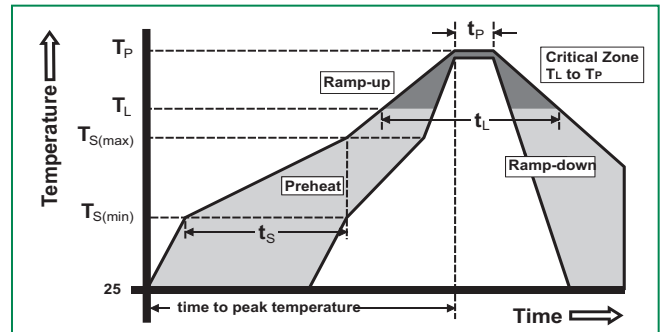

### Product Characteristics of 0402 DFN Package

<b>Lead Plating</b>	Pre-Plated Frame
<b>Lead Material</b>	Copper Alloy
<b>Lead Coplanarity</b>	0.004 inches(0.102mm)
<b>Substrate material</b>	Silicon
<b>Body Material</b>	Molded Epoxy
<b>Flammability</b>	UL 94 V-0

#### Notes :

1. All dimensions are in millimeters
2. Dimensions include solder plating.
3. Dimensions are exclusive of mold flash & metal burr.
4. Bto is facing up for mold and facing down for trim/form, i.e. reverse trim/form.
5. Package surface matte finish VDI 11-13.

**Package Dimensions — 0201 DFN**

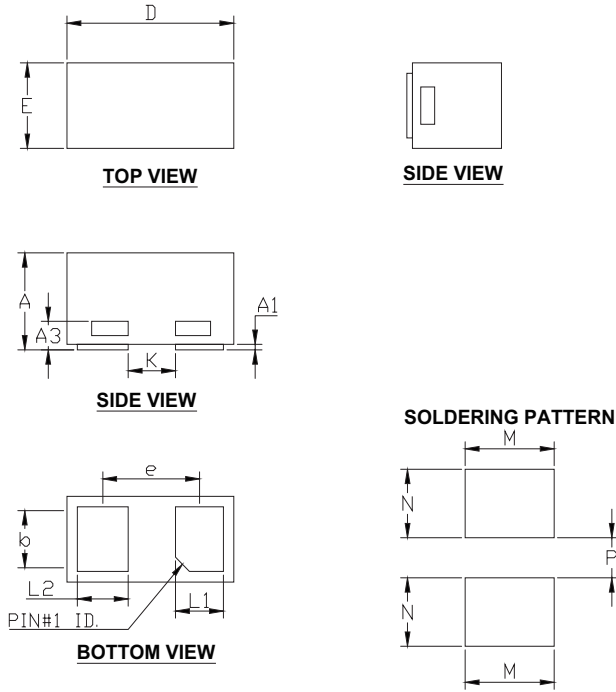

Symbol	Millimeters		Inches	
	Min	Max	Min	Max
A	0.23	0.33	0.009	0.013
A1	0.00	0.05	0.000	0.002
A3	0.100 ref.		0.004 ref.	
b	0.2	0.3	0.008	0.012
D	0.55	0.65	0.022	0.026
E	0.25	0.35	0.010	0.014
e	0.35-0.40 BSC		0.014-0.016 BSC	
L1	0.12	0.23	0.005	0.009
L2	0.12	0.24	0.005	0.009
K	0.17 BSC		0.007 BSC	
M	0.32		0.013	
N	0.24		0.009	
P	0.14		0.006	

**Package Dimensions — 0402 DFN**

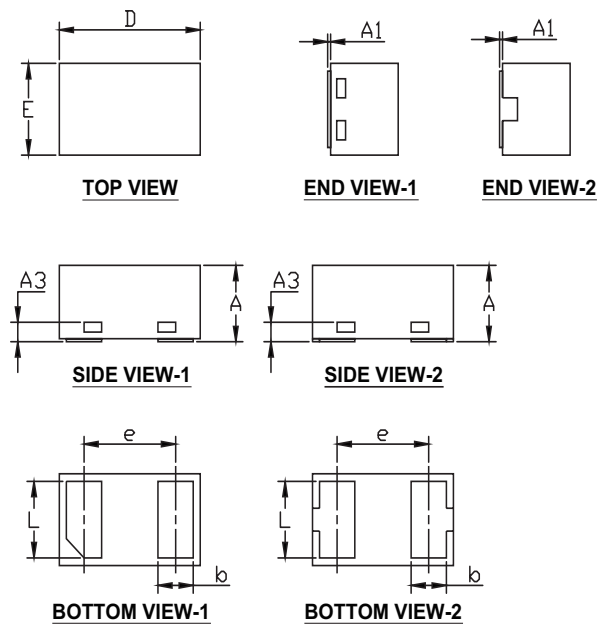

Symbol	Millimeters			Inches		
	Min	Typ	Max	Min	Typ	Max
A	0.33	-	0.55	0.013	-	0.022
A1	0	-	0.05	0.000	-	0.002
A3	0.13REF			0.005REF		
b	0.20	0.25	0.30	0.008	0.010	0.012
D	0.95	1.00	1.05	0.037	0.039	0.041
E	0.55	0.60	0.65	0.022	0.024	0.026
e	0.65BSC			0.026BSC		
L	0.45	0.50	0.55	0.018	0.020	0.022

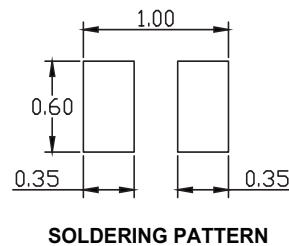

### Part Numbering System

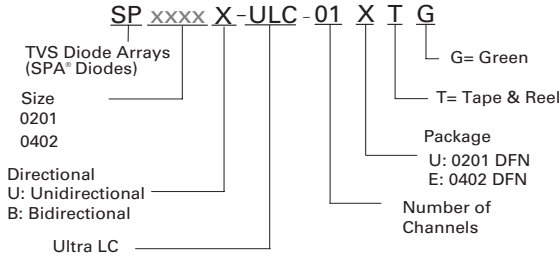

### Part Marking System

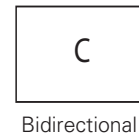
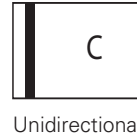

### Ordering Information

Part Number	Package	Marking	Reel Quantity
SP0201U-ULC-01UTG	0201 DFN	I C	15000
SP0201B-ULC-01UTG	0201 DFN	C	15000
SP0402U-ULC-01ETG	0402 DFN	I C	10000
SP0402B-ULC-01ETG	0402 DFN	C	10000

### Embossed Carrier Tape & Reel Specification – 0201 DFN

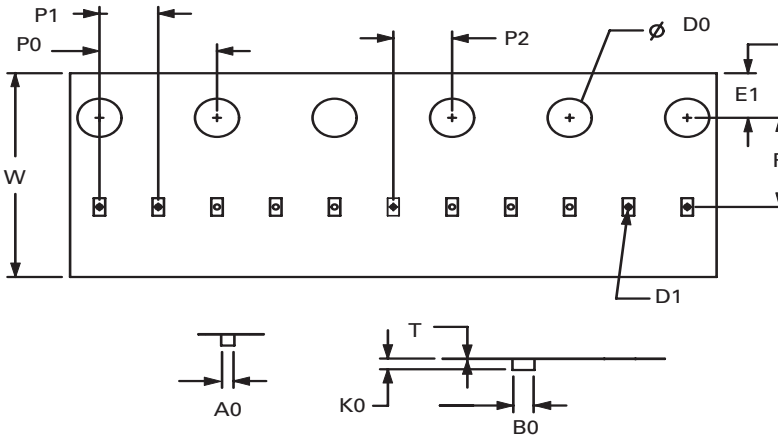

Symbol	Millimeters
A0	0.33 min/0.41 max
B0	0.63 min/0.71 max
D0	∅ 1.50 +0.10/-0
D1	∅ 0.20 +/- 0.05
E1	1.75 +/- 0.10
F	3.50 +/- 0.05
K0	0.30 min/0.39 max
P0	4.00 +/- 0.10
P1	2.00 +/- 0.10
P2	2.00 +/- 0.05
W	8.00 +0.30/-0.10
T	0.13 min/0.25 max

### Embossed Carrier Tape & Reel Specification – 0402 DFN

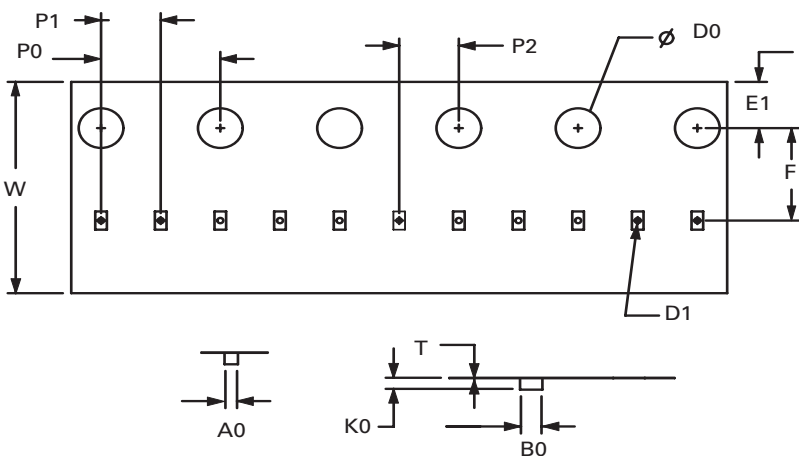

Symbol	Millimeters
A0	0.70 +/- 0.05
B0	1.15 +/- 0.05
D0	∅ 1.50 +/- 0.10
D1	∅ 0.40 +/- 0.10
E1	1.75 +/- 0.10
F	3.50 +/- 0.10
K0	0.55 +/- 0.05
P0	4.00 +/- 0.10
P1	2.00 +/- 0.10
P2	2.00 +/- 0.05
W	8.00 +0.30/-0.10
T	0.20 +/- 0.05