



Chipsmall Limited consists of a professional team with an average of over 10 year of expertise in the distribution of electronic components. Based in Hongkong, we have already established firm and mutual-benefit business relationships with customers from,Europe,America and south Asia,supplying obsolete and hard-to-find components to meet their specific needs.

With the principle of "Quality Parts,Customers Priority,Honest Operation,and Considerate Service",our business mainly focus on the distribution of electronic components. Line cards we deal with include Microchip,ALPS,ROHM,Xilinx,Pulse,ON,Everlight and Freescale. Main products comprise IC,Modules,Potentiometer,IC Socket,Relay,Connector.Our parts cover such applications as commercial,industrial, and automotives areas.

We are looking forward to setting up business relationship with you and hope to provide you with the best service and solution. Let us make a better world for our industry!



Contact us

Tel: +86-755-8981 8866 Fax: +86-755-8427 6832

Email & Skype: info@chipsmall.com Web: www.chipsmall.com

Address: A1208, Overseas Decoration Building, #122 Zhenhua RD., Futian, Shenzhen, China



Amplified “Zero Height” SiSonic™ Microphone with Enhanced RF Specification

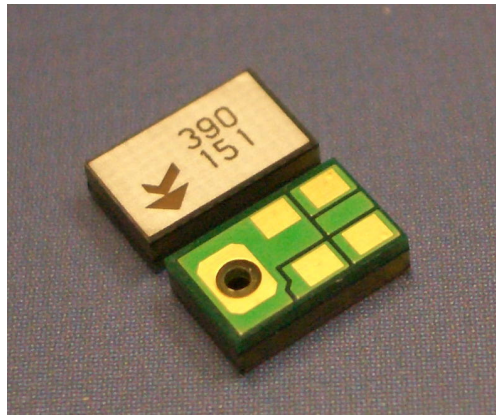

Knowles Acoustics
1151 Maplewood Drive
Itasca, IL 60143

1. DESCRIPTION AND APPLICATION

1.1 Description

Amplified “Zero Height” Surface Mount Silicon Microphone with Enhanced RF Protection

1.2 Application

Hand held telecommunication devices

2. PART MARKING

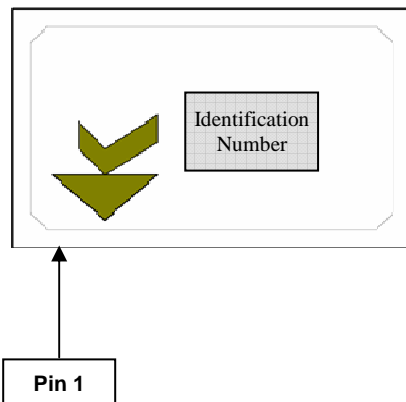

Identification Number Convention

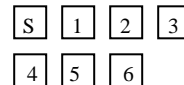

S: Manufacturing Location

“S” – Knowles Electronics Suzhou
Suzhou, China

“No Alpha Character” – Knowles Electronics Itasca
Itasca, IL USA

“E” – Engineering Samples

Digits 1 – 6: Job Identification Number

3. TEMPERATURE RANGE

3.1 Operating Temperature Range: -40°C to +100°C

3.2 Storage Temperature Range: -40°C to +100°C

4. ACOUSTIC & ELECTRICAL SPECIFICATIONS

Test Conditions: +20°C, 60-70% R.H.

	Symbol	Condition	Limits			Unit
			Min.	Nom.	Max.	
Directivity		Omni-directional				
Sensitivity	S	@ 1kHz (0dB=1V/Pa)	-25	-22	-19	dB
Output impedance	Z _{OUT}	@ 1kHz (0dB=1V/Pa)	n/a	n/a	300	Ω
Current Consumption	I _{DSS}	across 1.5 to 3.6 volts	0.100	n/a	0.350	mA
Signal to Noise Ratio	S/N	@ 1kHz (0dB=1V/Pa)	55	59	n/a	dB
Supply Voltage	V _s		1.5	n/a	3.6	V
Typical Input Referred Noise	ENL	A-weighted	n/a	35	n/a	dBA SPL
Sensitivity Loss across Voltage		Change in sensitivity over 3.6v to 1.5v	No Change Across Voltage Range			dB
Maximum Input Sound Level		At 100dB SPL, THD < 1% At 115dB SPL, THD = < 10%				dB
Operating Temperature			-40		+100	°Celsius
Storage Temperature			-40		+100	°Celsius
Contact Resistance					100	Ohms

5. FREQUENCY RESPONSE CURVE

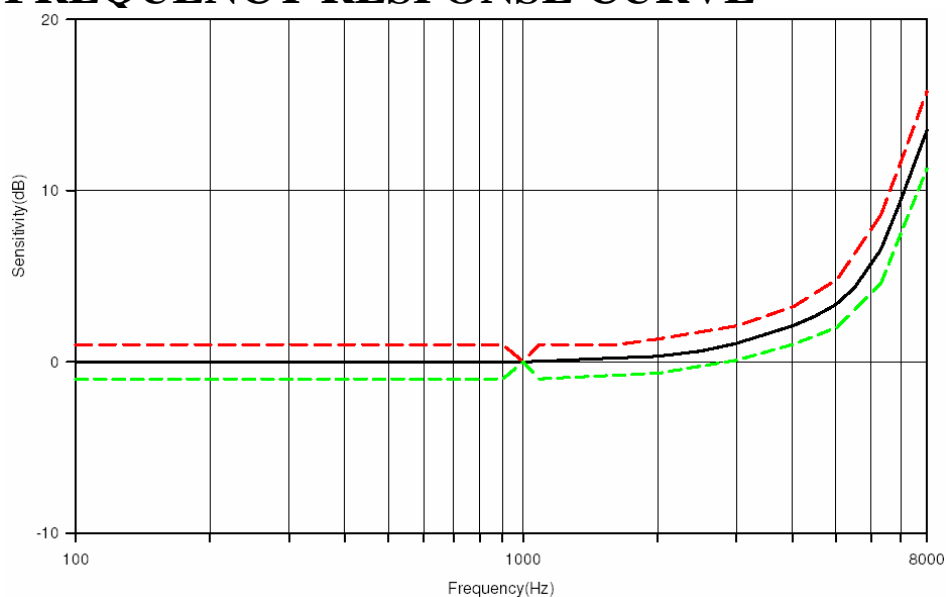

6. MECHANICAL SPECIFICATIONS

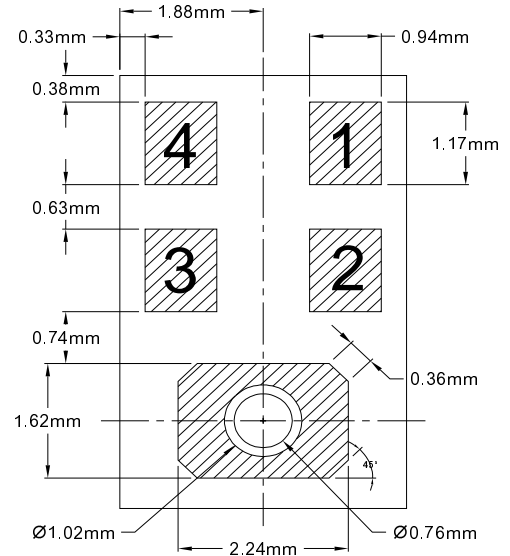
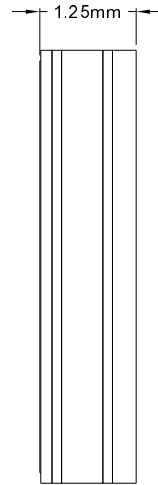
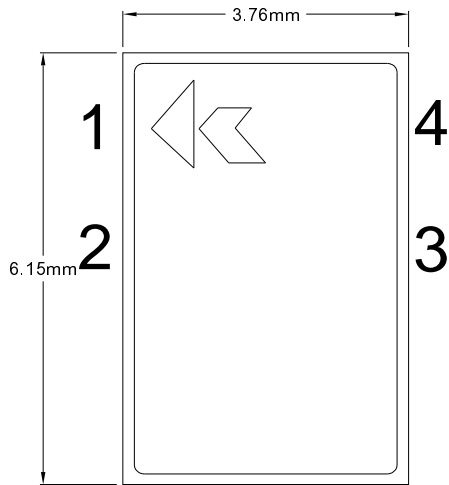

Pin Output	
Pin #	Function
1	Output
2	Gain Control
3	Ground
4	Power

Item	Dim.	Tol. (+/-)	Units
Height	1.25	0.10	mm
Length	6.15	0.10	mm
Width	3.76	0.10	mm
Weight	0.09	grams	
Coplanarity	< 0.1		mm

(Note: Tolerance +/-0.15mm unless otherwise specified)

7. RECOMMENDED CUSTOMER LAND PATTERN

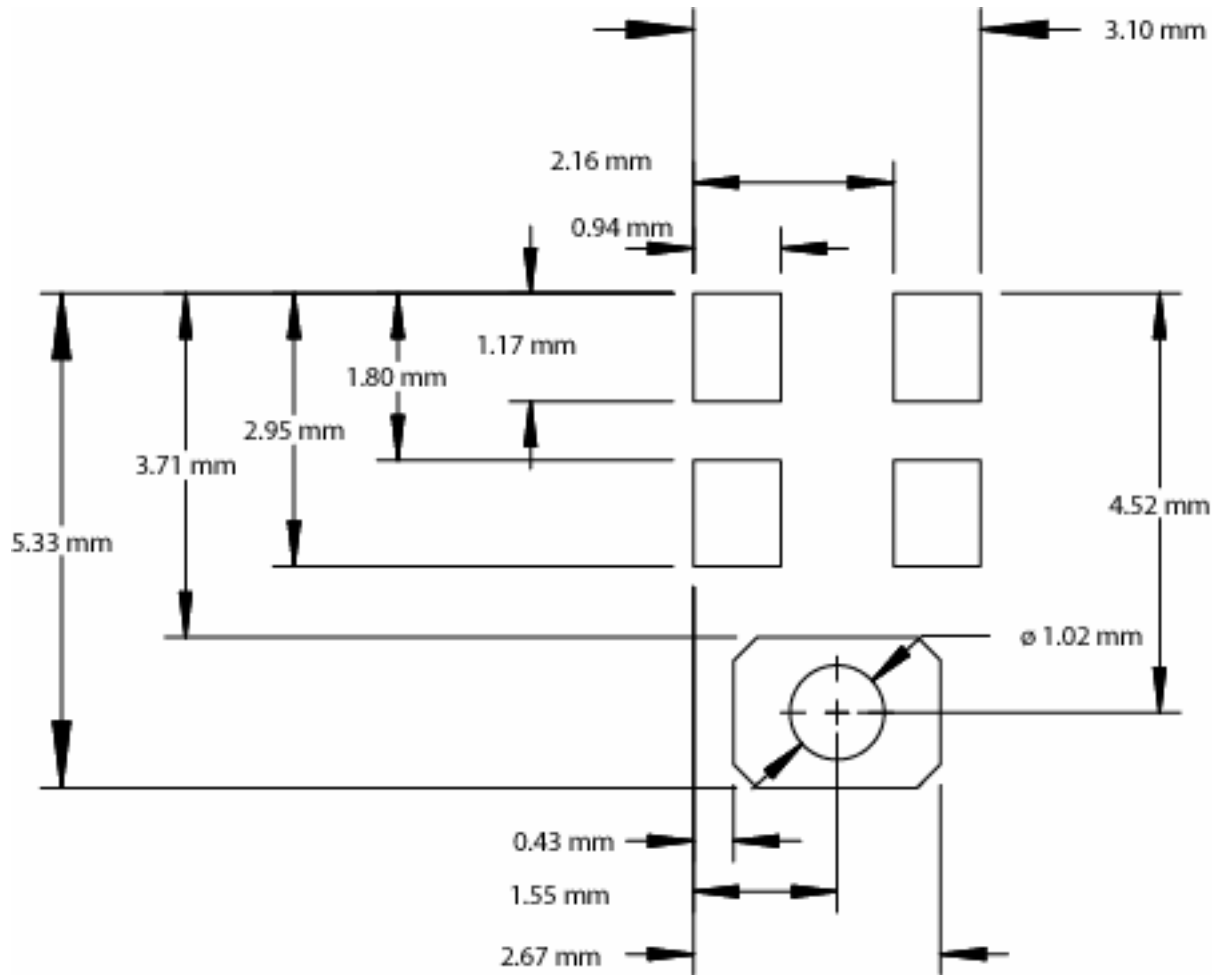

8. RECOMMENDED SOLDER STENCIL PATTERN

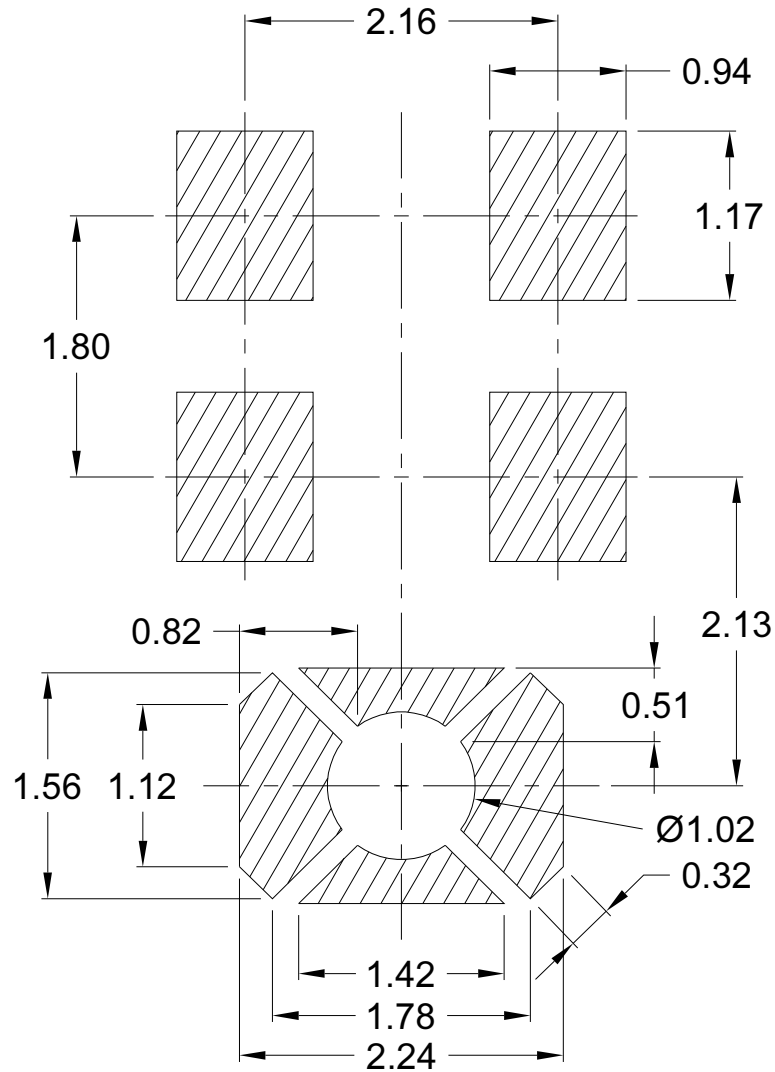

Notes:

- The design requires that an acoustic seal be established between the SiSonic and customer PCB. This is accomplished via a solder seal.
- Solder Stencil Thickness = 0.127 min to 0.178 max
- Stencil Material = Stainless Steel
- * $\text{Ø}1.50$ reference to maximum metal opening in customer PCB.

9. RECOMMENDED INTERFACE CIRCUIT

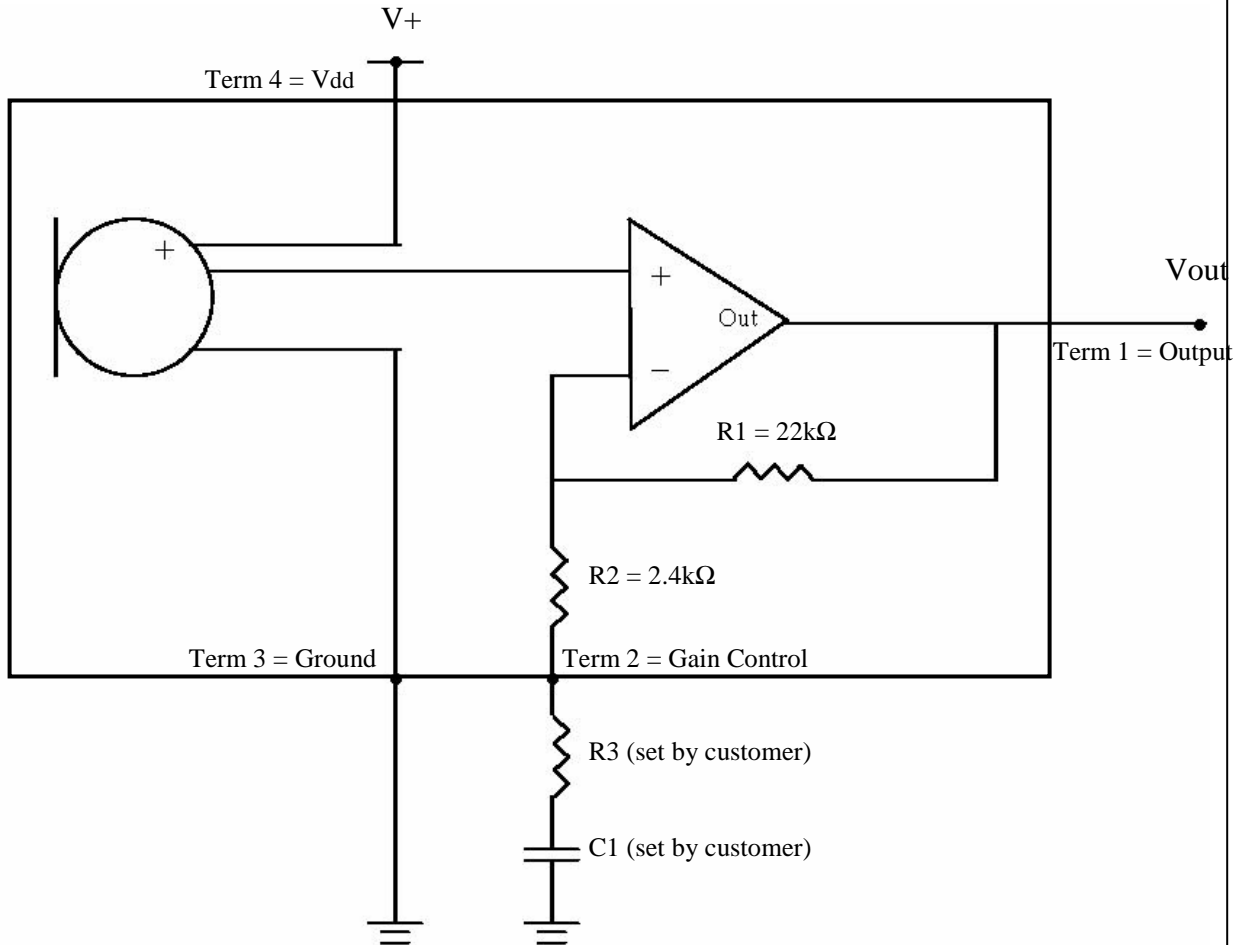

Desired Gain	Pin 2 Termination Method
Unity Gain (0dB)	Tie Terminal 2 directly to Output (Terminal 1).
20dB Gain	Tie Terminal 2 through C1 (0.47uF) to Ground.
Adjustable Gain	Add R3 and C1. Use formulas provided to calculate settings, or contact Knowles for support.

Setting Gain Formulas:

Gain of non-inverting Op-Amp is determined as:

$$\rightarrow G = 1 + \left\{ \frac{R1}{R2 + R3} \right\} \quad \text{Gain(dB)} = 20 * \log(G)$$

High-pass-filter Corner Frequency:

$$\rightarrow \text{C.F.} = 1 / \{ 2 * \pi * (R2 + R3) * C1 \}$$

10. PACKAGING DETAIL

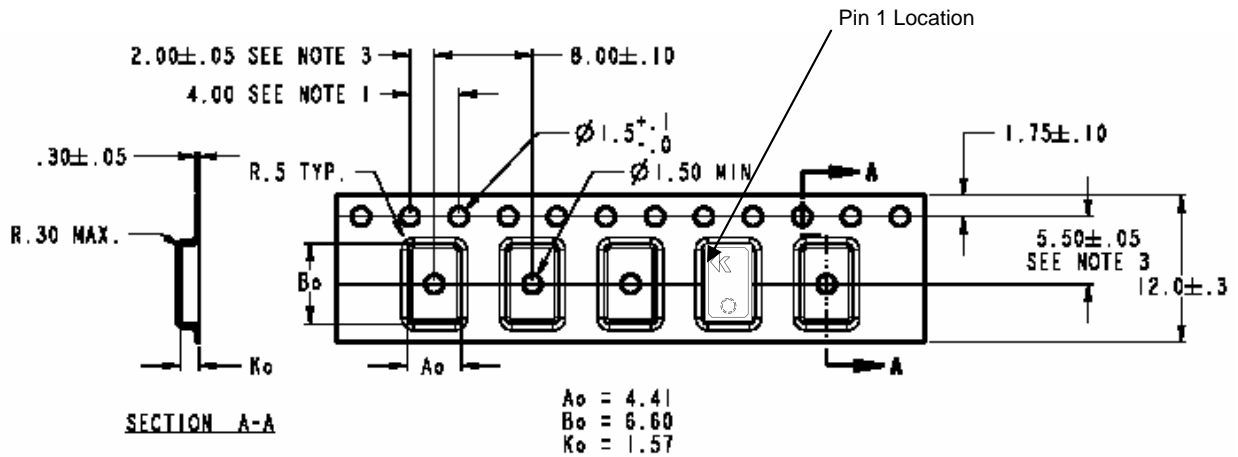

NOTES:

1. 10 SPROCKET HOLE PITCH CUMULATIVE TOLERANCE ± 0.2
2. CAMBER IN COMPLIANCE WITH EIA 481
3. POCKET POSITION RELATIVE TO SPROCKET HOLE MEASURED AS TRUE POSITION OF POCKET, NOT POCKET HOLE

Model Number	Suffix	Reel Diameter	Qty per Reel
SP0208LE5	-2	7"	1,200
SP0208LE5	-6	13"	4,800

Tape & Reel	Available in 13" and 7" diameter.
Leader Length	800mm or minimum of 100 empty pockets
Label	Label applied to external package and direct to reel. Per JEDEC.
Empty Units	No consecutive empty pockets; No more than 3 empty pockets per reel. (Does not include empty pockets for leader/follower)

11. SOLDER REFLOW PROFILE

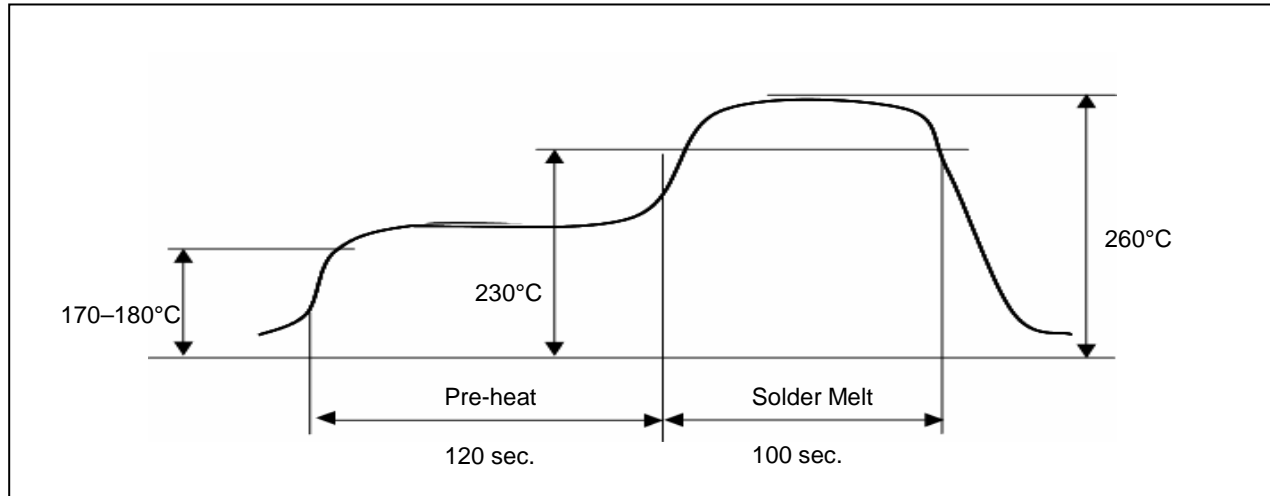

<i><u>Stage</u></i>	<i><u>Temperature Profile</u></i>	<i><u>Time (maximum)</u></i>
Pre-heat	170 ~ 180 C	120 sec.
Solder Melt	Above 230 C	100 sec.
Peak	260 C maximum	30 sec.

Notes:

1. Do not pull a vacuum over the port hole of the microphone. Pulling a vacuum over the port hole can damage the device.
2. Do not board wash after the reflow process. Board washing and cleaning agents can damage the device. Do not expose to ultrasonic processing or cleaning.
3. Number of Reflow = recommend no more than 3 cycles.

12. ADDITIONAL NOTES

- (A) Packaging (reference SiSonic_Packaging_Spec.pdf)
- (B) Shelf life: Twelve (12) months when devices are to be stored in factory supplied, unopened ESD moisture sensitive bag under maximum environmental conditions of 30°C, 70% R.H.
- (C) Exposure: Devices should not be exposed to high humidity, high temperature environment. MSL (moisture sensitivity level) Class 2A.
- (D) Out of bag: Maximum of 90 days out of ESD moisture sensitive bag, assuming maximum conditions of 30°C/70% R.H.

13. RELIABILITY SPECIFICATIONS

Note: After test conditions are performed, the sensitivity of the microphone shall not deviate more than 3dB from its initial value.

Test	Description
Thermal Shock	Microphone unit must operate when exposed to air-to-air thermal shock 100 cycles, from -40°C to +125°C. (IEC 68-2-4),
High Temperature Storage Test	Microphone unit must maintain sensitivity after storage at +105°C for 1,000 hours. (IEC 68-2-2 Test Ba)
Low Temperature Storage Test	Microphone unit must maintain sensitivity after storage at -40°C for 1,000 hours. (IEC 68-2-1 Test Aa)
High Temperature Operating Test	Microphone unit must operate within sensitivity specifications for 1,000 hours at 105°C. (IEC 68-2-2 Test Ba)
Low Temperature Operating Test	Microphone unit must operate within sensitivity specifications for 1,000 hours at -40°C. (IEC 68-2-1 Test Aa)
Humidity Test	Tested under Bias at 85°C/85% R.H. for 1,000 hours. (JESD22-A101A-B)
Vibration Test	Microphone unit must operate under test condition: 4 cycles, from 20 to 2,000 Hz in each direction (x,y,z), 48 minutes, using peak acceleration of 20g (+20%, -0%). (MIL 883E, method 2007.2, A)
Electrostatic Discharge	Tested to 8kV direct contact discharge to the case and tested to 2kV direct contact to I/O terminals.
Reflow	Microphone is tested to 5 passes through reflow oven, with microphone mounted upside-down under conditions of 260°C for 30 seconds maximum.
Mechanical Shock	Microphone must operate after exposure to shock test of 10,000 G per IEC 68-2-27, Ea.

14. SPECIFICATION REVISIONS

Revision	Detailed Specification Changes	Date
A	Preliminary Specification - Initial Release	06-10-2006
B	Specification Release	08-03-2006