



Chipsmall Limited consists of a professional team with an average of over 10 year of expertise in the distribution of electronic components. Based in Hongkong, we have already established firm and mutual-benefit business relationships with customers from,Europe,America and south Asia,supplying obsolete and hard-to-find components to meet their specific needs.

With the principle of “Quality Parts,Customers Priority,Honest Operation,and Considerate Service”,our business mainly focus on the distribution of electronic components. Line cards we deal with include Microchip,ALPS,ROHM,Xilinx,Pulse,ON,Everlight and Freescale. Main products comprise IC,Modules,Potentiometer,IC Socket,Relay,Connector.Our parts cover such applications as commercial,industrial, and automotives areas.

We are looking forward to setting up business relationship with you and hope to provide you with the best service and solution. Let us make a better world for our industry!



Contact us

Tel: +86-755-8981 8866 Fax: +86-755-8427 6832

Email & Skype: info@chipsmall.com Web: www.chipsmall.com

Address: A1208, Overseas Decoration Building, #122 Zhenhua RD., Futian, Shenzhen, China



GENERAL DESCRIPTION

The SP2525A device is an integrated high-side power switch ideal for self-powered and bus-powered Universal Serial Bus (USB) applications.

The high-side switches are MOSFETs with $70\text{m}\Omega$ $R_{DS(ON)}$, which meets USB voltage drop requirements for maximum transmission wire length. Multi-purpose open-drain fault flag output indicates over-current limiting, thermal shutdown, or under voltage lockout. Output current is typically limited to 0.85A below the 5A safety requirement, and the thermal shutdown function shuts the switch off to prevent damage under overcurrent conditions. Guaranteed minimum output rise time limits inrush current during hot plug-in, minimizing EMI and preventing the voltage at the upstream port from dropping excessively.

The SP2525A is offered in a RoHS compliant "green"/halogen free 8-pin NSOIC package.

APPLICATIONS

- **Self Powered USB 2.0 and 3.0 Hubs**
- **USB Compliant V_{BUS} Power Distribution**
- **Audio-Video Equipments**
- **Generic Power Switching**

FEATURES

- **+3.0V to +5.5V Input Voltage Range**
- **500mA Continuous Load Current per Channel**
- **2.6V Undervoltage Lockout**
- **1.25A Short Circuit Current Limit**
- **100m Ω Maximum On-Resistance**
- **75 μ A On-State Supply Current**
- **1 μ A Shutdown Current**
- **Output can be Forced Higher than Input (Off-State)**
- **Thermal Shutdown**
- **Slow Turn On and Fast Turn Off**
- **Active-high Version: SP2525A-1**
- **Active-low Version: SP2525A-2**
- **RoHS Compliant, Green/Halogen Free 8-Pin NSOIC Package**

TYPICAL APPLICATION DIAGRAM

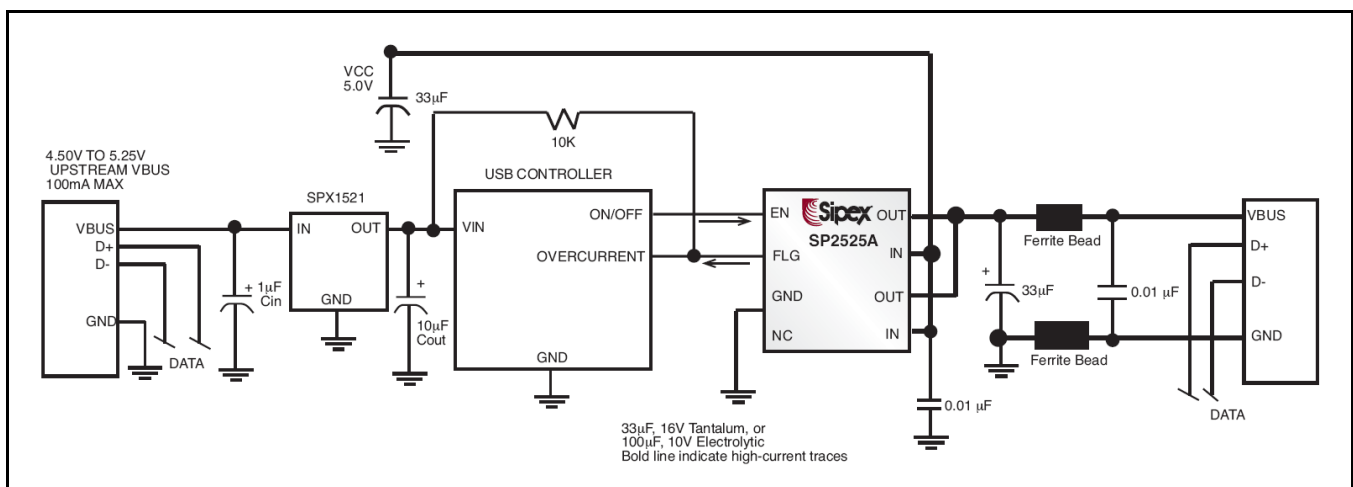

Fig. 1: SP2525A Application Diagram – Single Port Self Powered Hub



ABSOLUTE MAXIMUM RATINGS

These are stress ratings only and functional operation of the device at these ratings or any other above those indicated in the operation sections of the specifications below is not implied. Exposure to absolute maximum rating conditions for extended periods of time may affect reliability.

Supply Voltage V_{IN} 7.0V
 Fault Flag Voltage V_{FLG} 7.0V
 Fault Flag Current I_{FLG} 50mA
 Enable Input V_{EN} -0.3V to 15V
 Storage Temperature -65°C to 150°C
 Power Dissipation (NSOIC-8)
 (derate 6.14mW/°C above 70°C)..... 500mW

OPERATING RATINGS

Ambient Temperature Range -40°C to 85°C

ELECTRICAL SPECIFICATIONS

Specifications with standard type are for an Operating Ambient Temperature of $T_A = 25^\circ\text{C}$ only; limits applying over the full Operating Junction Temperature range are denoted by a “•”. Minimum and Maximum limits are guaranteed through test, design, or statistical correlation. Typical values represent the most likely parametric norm at $T_A = 25^\circ\text{C}$, and are provided for reference purposes only. Unless otherwise indicated, $V_{IN} = 5.0\text{V}$, $T_A = 25^\circ\text{C}$.

Parameter	Min.	Typ.	Max.	Units	Conditions
Supply Current		0.75	5.0	μA	$V_{EN} = \text{Logic "0"}$ OUT =open
		75	100		$V_{EN} = \text{Logic "1"}$ OUT =open
Enable Input Voltage	0.8	1.7		V	$V_{EN} = \text{Logic "0"}$
		2.0	2.4		$V_{EN} = \text{Logic "1"}$
Enable Input Current		0.01	1	μA	$V_{EN} = \text{Logic "0"}$
		0.01	1		$V_{EN} = \text{Logic "1"}$
Enable Input Capacitance		1		pF	
Output MOSFET Resistance		70	100	$\text{m}\Omega$	
Output turn-on delay		100		μs	$R_L = 10\Omega$, each output
Output turn-on rise time		1000	4000	μs	$R_L = 10\Omega$, each output
Output turn-off delay		0.8	20	μs	$R_L = 10\Omega$, each output
Output turn-off fall time		0.7	20	μs	$R_L = 10\Omega$, each output
Output Leakage Current			10	μA	
Current limit threshold	0.6	1.0	1.25	A	
Over temperature shutdown threshold		135		$^\circ\text{C}$	Temperature T_J raising
		125			Temperature T_J decreasing
Error Flag Output Resistance		10	25	Ω	$V_{IN} = 5\text{V}$, $I_L = 10\text{mA}$
		15	40		$V_{IN} = 3.3\text{V}$, $I_L = 10\text{mA}$
Error Flag Current		0.01	1	μA	
UVLO threshold		2.6		V	V_{IN} increasing
		2.4			V_{IN} decreasing

BLOCK DIAGRAM

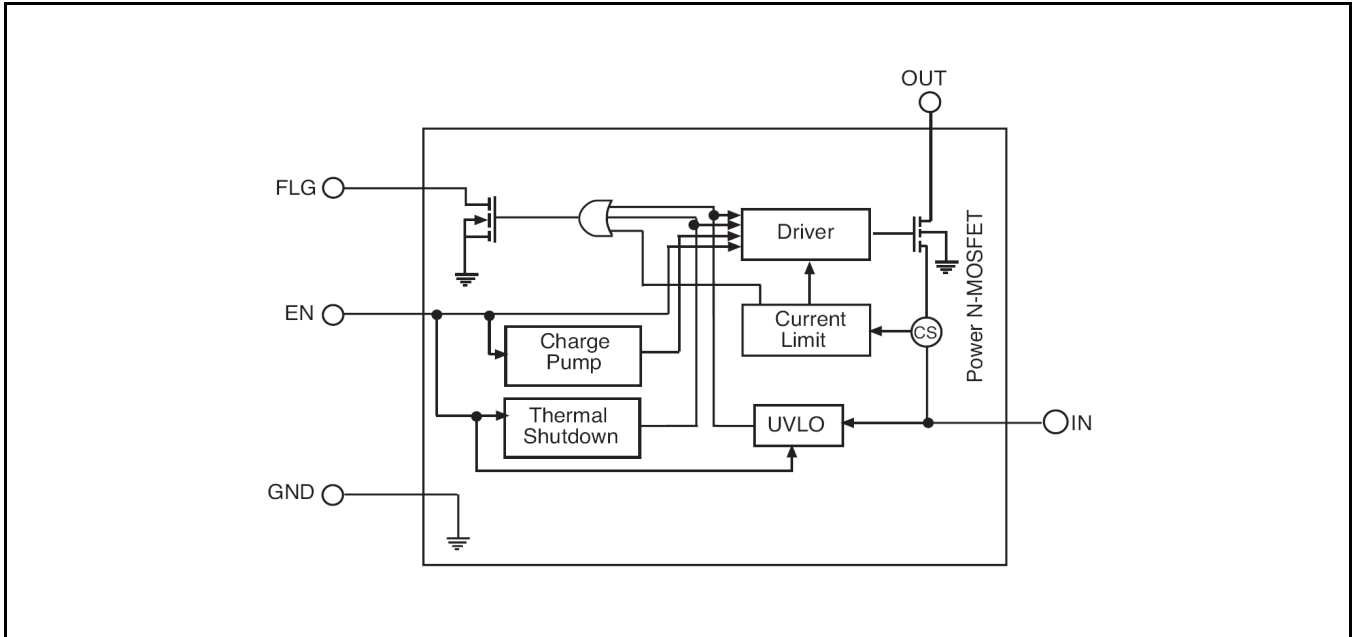

Fig. 2: SP2525A Block Diagram

PIN ASSIGNMENT

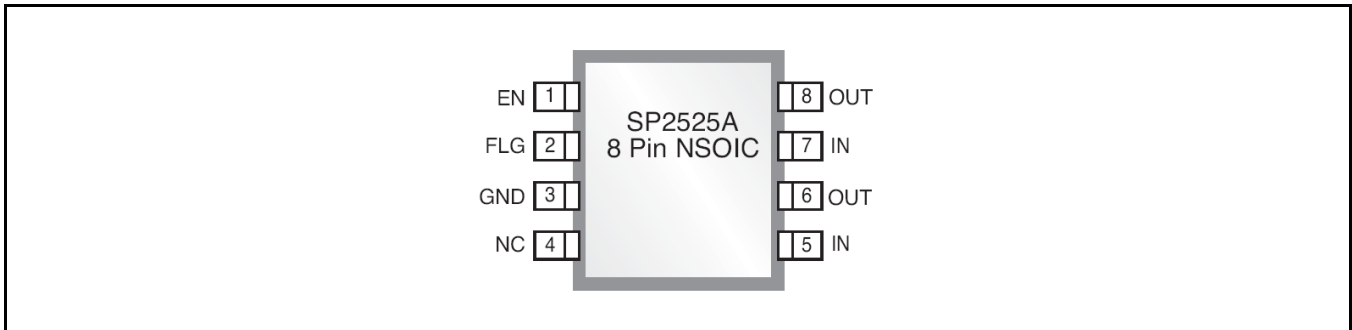

Fig. 3: SP2525A Pin Assignment

PIN DESCRIPTION

Name	Pin Number	Description
EN	1	Enable Input Active High for SP2525A-1 and Active Low for SP2525A-2
FLG	2	An active-low and open-drained fault flag output for power switch. It can indicate current limit if CTL is active. In normal mode operation, it also can indicate thermal shutdown or under voltage
GND	3	Chip Power Ground
NC	4	Not Internally Connected
IN	5, 7	Power Supply Input
OUT	6, 8	MOSFET Switch Output



ORDERING INFORMATION

Part Number	Temperature Range	Marking	Package	Packing Quantity	Note 1	Note 2
SP2525A-1EN-L	$-40^{\circ}\text{C} \leq T_A \leq +85^{\circ}\text{C}$	Sipex 2525A-1E YYWWL	NSOIC8	Bulk	RoHS Compliant Halogen Free	Enable Active high
SP2525A-1EN-L/TR	$-40^{\circ}\text{C} \leq T_A \leq +85^{\circ}\text{C}$			2.5K/Tape & Reel		
SP2525A-2EN-L	$-40^{\circ}\text{C} \leq T_A \leq +85^{\circ}\text{C}$	Sipex 2525A-2E YYWWL	NSOIC8	Bulk	RoHS Compliant Halogen Free	Enable Active Low
SP2525A-2EN-L/TR	$-40^{\circ}\text{C} \leq T_A \leq +85^{\circ}\text{C}$			2.5K/Tape & Reel		

"YY" = Year - "WW" = Work Week - "X" = Lot Number

TYPICAL PERFORMANCE CHARACTERISTICS

All data taken at $V_{IN} = 5.0V$, $T_A = 25^\circ C$, unless otherwise specified - Schematic and BOM from Application Information section of this datasheet.

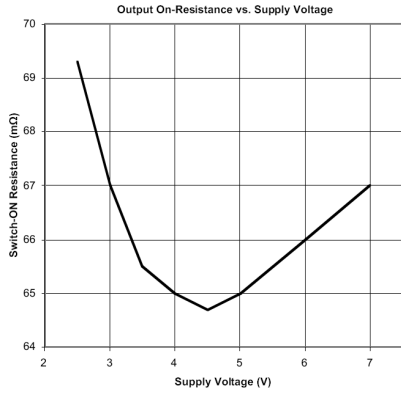

Fig. 4: Output On-Resistance vs Supply Voltage

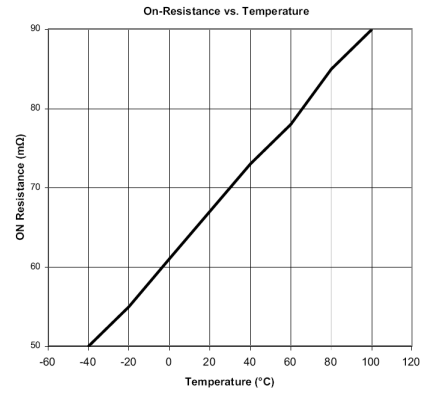

Fig. 5: Output On-Resistance vs Temperature

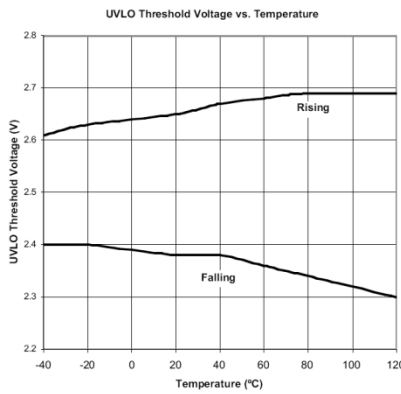

Fig. 6: UVLO Threshold vs Temperature

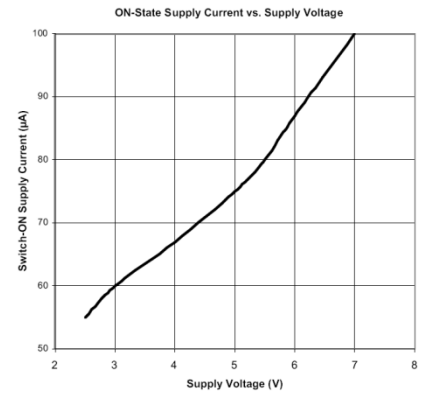

Fig. 7: On-state Supply Current vs Supply Voltage

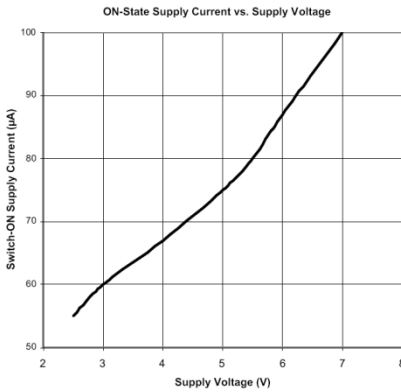

Fig. 8: On-state Supply Current vs Temperature

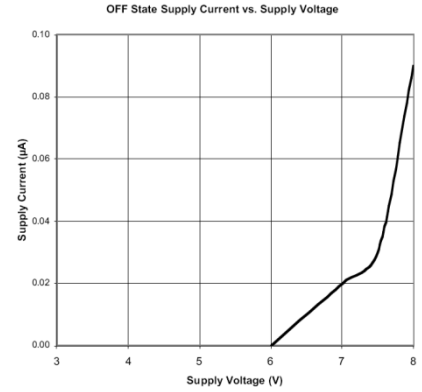

Fig. 9: Off-state Supply Current vs Supply Voltage

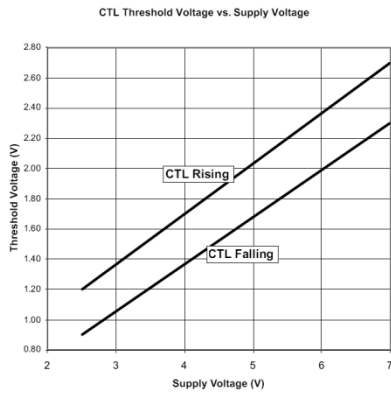

Fig. 10: CTL Threshold vs Supply Voltage

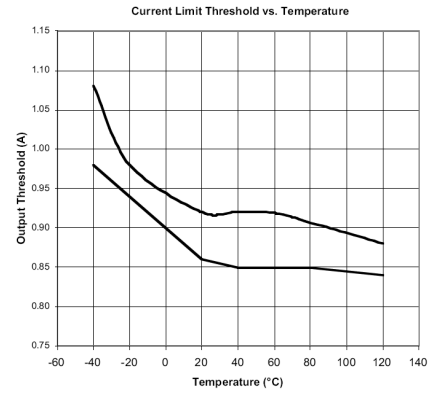

Fig. 11: Current Limit Threshold vs Temperature

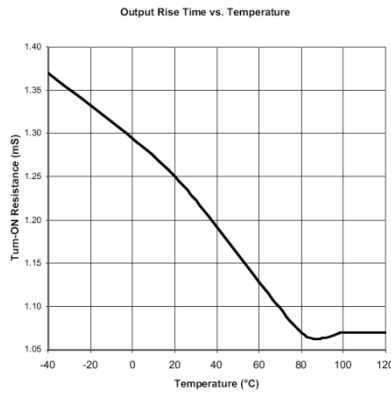

Fig. 12: Output Rise Time vs Temperature

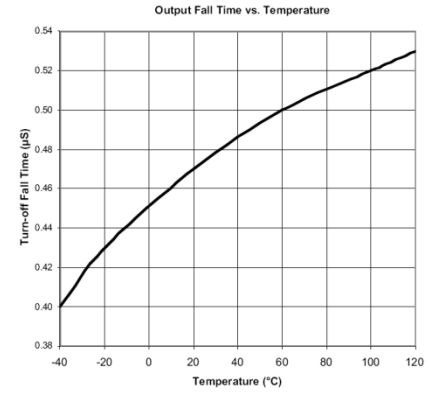

Fig. 13: Output Fall Time vs Temperature

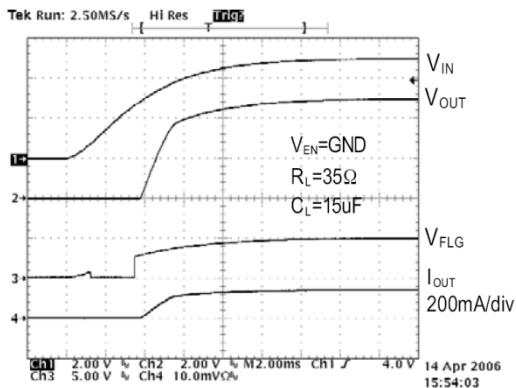

Fig. 14: Input Voltage Response

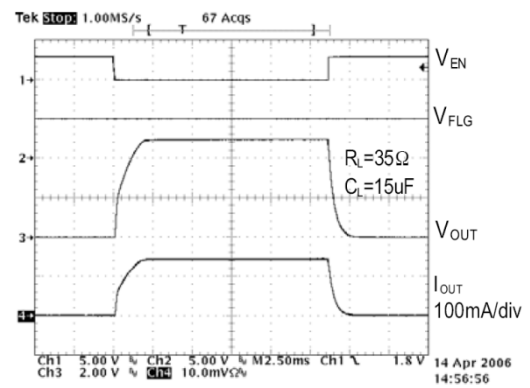

Fig. 15: Turn-On, Turn-Off Characteristics

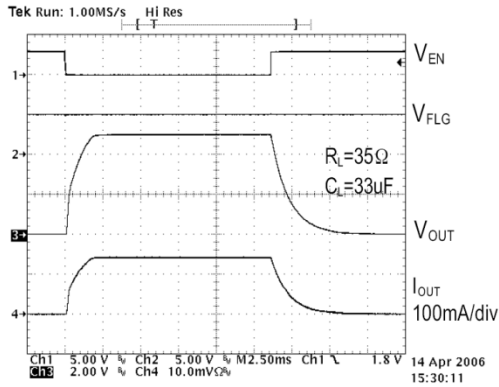

Fig. 16: Turn-On, Turn-Off Characteristics

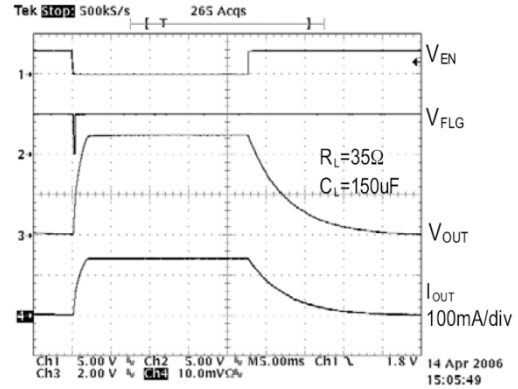

Fig. 17: Turn-On, Turn-Off Characteristics

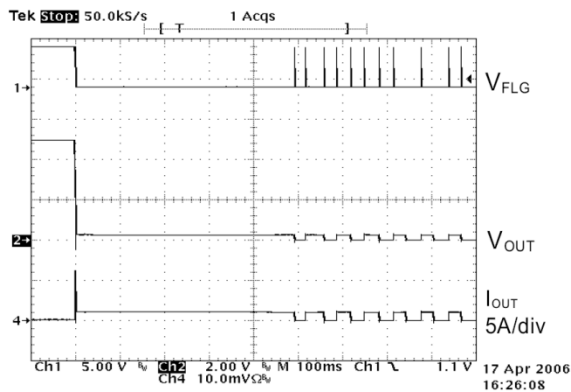

Fig. 18: Short Circuit Response
(Short applied to Output)

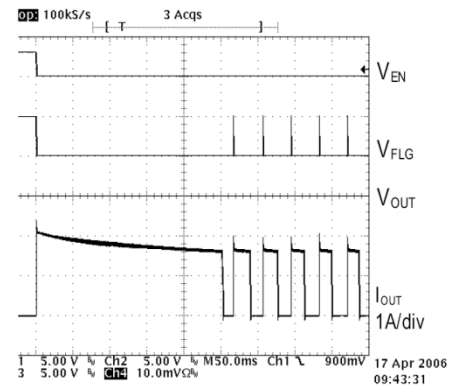

Fig. 19: Short Circuit Response
(Enable to Short Circuit)

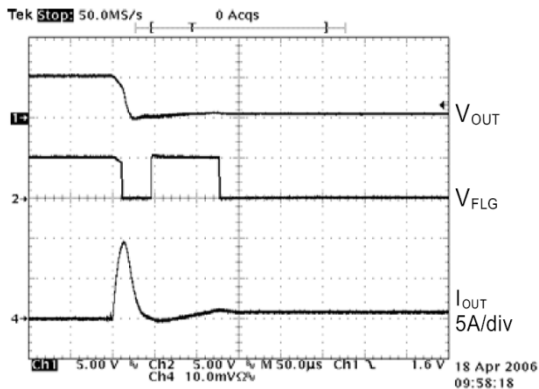

Fig. 20: Short Circuit Transient Response
(Short applied to Output)

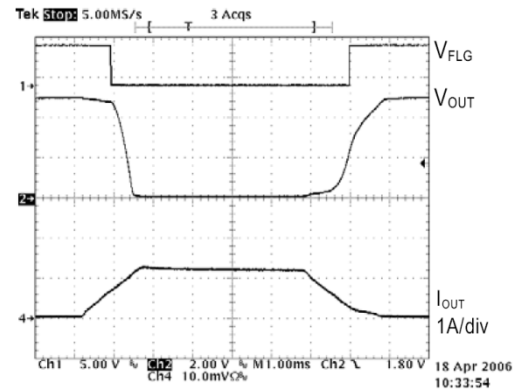

Fig. 21: Current Limit Response
(Ramped Load)

APPLICATION INFORMATION

ERROR FLAG

The Error Flag is an open-drained output of an N-channel MOSFET, the FLG output is pulled low to signal the following fault conditions: input undervoltage, output current limit, and thermal shutdown.

CURRENT LIMIT

The current limit threshold is preset internally. It protects the output MOSFET switches from damage resulting from undesirable short circuit conditions or excess inrush current, which is often encountered during hot plug-in. The low limit of the current limit threshold of the SP2525A allows a minimum current of 0.5A through the MOSFET switches. A current limit condition will signal the Error Flag.

THERMAL SHUTDOWN

When the temperature of the SP2525A exceeds 135°C for any reasons, the thermal shutdown function turns off the MOSFET switch and signals the Error Flag. A hysteresis of 10°C prevents the MOSFETs from turning back on until the chip temperature drops below 125°C.

SUPPLY FILTERING

A 0.1µF to 1µF bypass capacitor from IN to GND, located near the device, is strongly recommended to control supply transients. Without a bypass capacitor, an output short may cause ringing on the input (from supply lead inductance) which can damage internal control circuitry.

TRANSIENT REQUIREMENTS

USB supports dynamic attachment (hot plugin) of peripherals. A current surge is caused by the input capacitance of a downstream device. Ferrite beads are recommended in series with all power and ground connector pins. Ferrite beads reduce EMI and limit the inrush current during hot-attachment by filtering high-frequency signals.

SHORT CIRCUIT TRANSIENT

Bulk capacitance provides the short-term transient current needed during a hot-attachment event. A 33µF/16V tantalum or a 100µF/ 10V electrolytic capacitor mounted close to the downstream connector at each port should provide sufficient transient drop protection.

PRINTED CIRCUIT LAYOUT

The Power circuitry of USB printed circuit boards requires a customized layout to maximize thermal dissipation and to minimize voltage drop and EMI.

INPUT AND OUTPUT

The independent solid state switch connects the IN pin to the OUT pin when enabled by a logic signal at EN. The IN pin is the power supply connection to the internal circuitry and the drain of the output MOSFET. The OUT pin is the source for the MOSFET. Typically, the current in USB application will flow through the switch from IN to OUT towards the load. If VOUT is greater than VIN when a switch is enabled, the current will flow from OUT to the IN pin because the MOSFET channels are bidirectional when switched on. The output source is allowed to be externally forced to a higher voltage than its input without causing unwanted current flow when the output is disabled.

TEST CIRCUIT

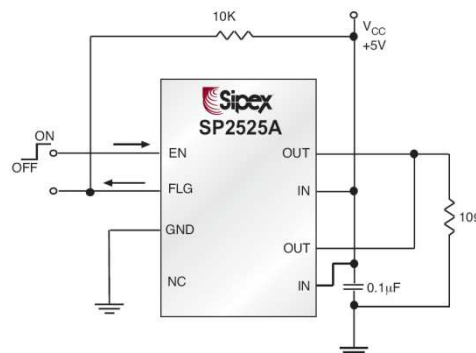

PACKAGE SPECIFICATION

8-PIN NSOIC

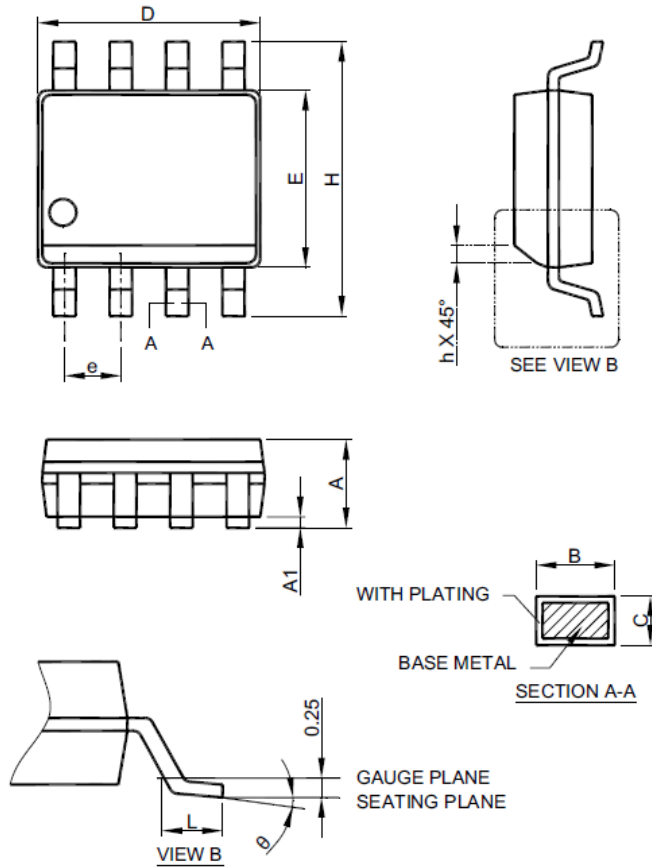

- Note: 1. Refer to JEDEC MS-012AA.
 2. Dimension "D" does not include mold flash, protrusions or gate burrs. Mold flash, protrusion or gate burrs shall not exceed 6 mil per side .
 3. Dimension "E" does not include inter-lead flash or protrusions.
 4. Controlling dimension is millimeter, converted inch dimensions are not necessarily exact.

SYMBOL	8 PIN SOICN	
	MILLIMETERS	
	MIN.	MAX.
A	1.35	1.75
A1	0.10	0.25
B	0.33	0.51
C	0.19	0.25
D	4.80	5.00
E	3.80	4.00
e	1.27 BSC	
H	5.80	6.20
h	0.25	0.50
L	0.40	1.27
θ	0°	8°



REVISION HISTORY

Revision	Date	Description
2.0.0	11/10/2010	Reformat of datasheet
2.1.1	11/04/2011	Updated package specification

FOR FURTHER ASSISTANCE

Email: customersupport@exar.com
Exar Technical Documentation: <http://www.exar.com/TechDoc/default.aspx?>

EXAR CORPORATION

HEADQUARTERS AND SALES OFFICES

48720 Kato Road
Fremont, CA 94538 – USA
Tel.: +1 (510) 668-7000
Fax: +1 (510) 668-7030
www.exar.com



NOTICE

EXAR Corporation reserves the right to make changes to the products contained in this publication in order to improve design, performance or reliability. EXAR Corporation assumes no responsibility for the use of any circuits described herein, conveys no license under any patent or other right, and makes no representation that the circuits are free of patent infringement. Charts and schedules contained here in are only for illustration purposes and may vary depending upon a user's specific application. While the information in this publication has been carefully checked; no responsibility, however, is assumed for inaccuracies.

EXAR Corporation does not recommend the use of any of its products in life support applications where the failure or malfunction of the product can reasonably be expected to cause failure of the life support system or to significantly affect its safety or effectiveness. Products are not authorized for use in such applications unless EXAR Corporation receives, in writing, assurances to its satisfaction that: (a) the risk of injury or damage has been minimized; (b) the user assumes all such risks; (c) potential liability of EXAR Corporation is adequately protected under the circumstances.

Reproduction, in part or whole, without the prior written consent of EXAR Corporation is prohibited.