



Chipsmall Limited consists of a professional team with an average of over 10 year of expertise in the distribution of electronic components. Based in Hongkong, we have already established firm and mutual-benefit business relationships with customers from,Europe,America and south Asia,supplying obsolete and hard-to-find components to meet their specific needs.

With the principle of “Quality Parts,Customers Priority,Honest Operation,and Considerate Service”,our business mainly focus on the distribution of electronic components. Line cards we deal with include Microchip,ALPS,ROHM,Xilinx,Pulse,ON,Everlight and Freescale. Main products comprise IC,Modules,Potentiometer,IC Socket,Relay,Connector.Our parts cover such applications as commercial,industrial, and automotives areas.

We are looking forward to setting up business relationship with you and hope to provide you with the best service and solution. Let us make a better world for our industry!



Contact us

Tel: +86-755-8981 8866 Fax: +86-755-8427 6832

Email & Skype: info@chipsmall.com Web: www.chipsmall.com

Address: A1208, Overseas Decoration Building, #122 Zhenhua RD., Futian, Shenzhen, China





SP332

RS-232/RS-485 Multi-mode Serial Transceiver

- +5V Only Single Supply Operation
- Software Programmable RS-232 or RS-485 Selection
- 4 Drivers, 4 Receivers RS-232
- 2 Drivers, 2 Receivers RS-485
- Loop back function for Self Test
- 28-pin WSOIC package

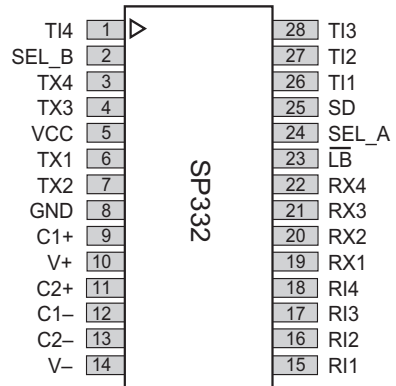

DESCRIPTION

The **SP332** is a monolithic device that contains both RS-232 and RS-485 line drivers and receivers. The configuration of the **SP332** can be changed at any time by changing the logic state of two control pins. The device also includes a loop back function which internally connects driver outputs to receiver inputs for a chip self test. An **Exar**-patented charge pump allows +5V-only operation.

TYPICAL APPLICATIONS CIRCUIT

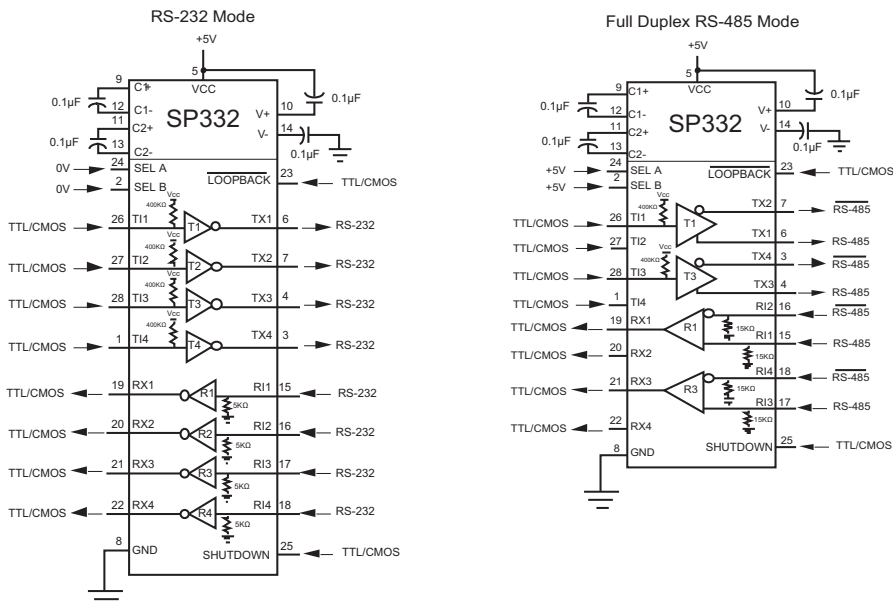

ABSOLUTE MAXIMUM RATINGS

ABSOLUTE MAXIMUM RATINGS

These are stress ratings only and functional operation of the device at these ratings or any other above those indicated in the operation sections of the specifications below is not implied. Exposure to absolute maximum rating conditions for extended periods of time may affect reliability.

V _{CC}	+7V
Input Voltages	
Logic.....	-0.5V to (V _{CC} +0.5V)
Drivers.....	-0.5V to (V _{CC} +0.5V)
Receivers.....	+/-30V @ ≤100mA
Driver Outputs.....	+/-15V
Maximum Data Rate.....	.8Mbps (Note 1)

Storage Temperature.....	-65°C to +150°C
Power Dissipation	
28-pin WSOIC.....	1000mW
Package Derating:	
28-pin WSOIC	
θ _{JA}40 °C/W

SPECIFICATIONS

Limits are specified at T_A = 25°C and V_{CC} = +5.0V unless otherwise noted.

PARAMETER	MIN.	TYP.	MAX.	UNITS	CONDITIONS
RS-485 DRIVER					
DC Characteristics					
Differential Output Voltage	GND		V _{CC}	Volts	Unloaded; R = ∞; See Figure 1
Differential Output Voltage	2.0		5.0	Volts	With load; R = 50Ω (RS-422); See Figure 1
Differential Output Voltage	1.5		5.0	Volts	With load; R = 27Ω (RS-485); See Figure 1
Change in Magnitude of Driver Differential Output Voltage for Complementary States			0.2	Volts	R = 27Ω or R = 50Ω; See Figure 1
Driver Common-Mode Output Voltage			3	Volts	R = 27Ω or R = 50Ω; See Figure 1
Input High Voltage	2.0			Volts	Applies to transmitter inputs, SEL A, SEL B, SD and LB
Input Low Voltage			0.8	Volts	Applies to transmitter inputs, SEL A, SEL B, SD and LB
Input Current			+/-10	μA	Applies to transmitter inputs, SEL A, SEL B, SD and LB
Pull-Up Current		1.5		μA	
Pull-Down Current		3.0		μA	
Driver Short Circuit Current V _{OUT} = HIGH	35		250	mA	-7V ≤ V _O ≤ 10V
Driver Short Circuit Current V _{OUT} = LOW	35		250	mA	-7V ≤ V _O ≤ 10V
AC Characteristics					
Driver Data Rate	10			Mbps	
Driver Data Rate			8	Mbps	T _A = +85°C, Note 1
Driver Input to Output t _{PLH}		70	180	ns	R _{DIFF} = 54Ω, C _{L1} = C _{L2} = 100pF; See Figures 3 and 5
Driver Input to Output t _{PHL}		70	180	ns	R _{DIFF} = 54Ω, C _{L1} = C _{L2} = 100pF; See Figures 3 and 5

SPECIFICATIONS (continued)

Limits are specified at $T_A = 25^\circ\text{C}$ and $V_{CC} = +5.0\text{V}$ unless otherwise noted.

PARAMETER	MIN.	TYP.	MAX.	UNITS	CONDITIONS
RS-485 DRIVER (Continued)					
AC Characteristics					
Driver Skew		5	10	ns	From Output to Output; See Figures 3 and 5
Driver Rise or Fall Time	3	15	40	ns	From 10% to 90%; $R_{DIFF} = 54\Omega$, $C_{L1} = C_{L2} = 100\text{pF}$; See Figures 3 and 5
RS-485 RECEIVER					
DC Characteristics					
Differential Input Threshold	-0.2		+0.2	Volts	$-7\text{V} \leq V_{CM} \leq 12\text{V}$
Input Hysteresis		70		mV	$V_{CM} = 0\text{V}$
Output Voltage HIGH	3.5			Volts	$I_O = -4\text{mA}$, $V_{ID} = +200\text{mV}$
Output Voltage LOW			0.4	Volts	$I_O = +4\text{mA}$, $V_{ID} = -200\text{mV}$
Input Resistance	12	15		k Ω	$-7\text{V} \leq V_{CM} \leq 12\text{V}$
Input Current (A, B); $V_{IN} = 12\text{V}$			1.5	mA	$V_{IN} = 12\text{V}$, A is the non-inverting receiver input. B is the inverting receiver input
Input Current (A, B); $V_{IN} = -7\text{V}$			-0.8	mA	$V_{IN} = -7\text{V}$
Short Circuit Current			85	mA	$0\text{V} \leq V_{CM} \leq V_{CC}$
AC Characteristics					
Receiver Data Rate	10			Mbps	
Receiver Data Rate			8	Mbps	$T_A = +85^\circ\text{C}$, Note 1
Receiver Input to Output t_{PLH}		130	250	ns	$R_{DIFF} = 54\Omega$, $C_{L1} = C_{L2} = 100\text{pF}$; Figures 3 and 6
Receiver Input to Output t_{PHL}		130	250	ns	$R_{DIFF} = 54\Omega$, $C_{L1} = C_{L2} = 100\text{pF}$; Figures 3 and 6
Differential Receiver Skew $ t_{PHL} - t_{PLH} $		13		ns	$R_{DIFF} = 54\Omega$, $C_{L1} = C_{L2} = 100\text{pF}$; Figures 3 and 6
RS-232 DRIVER					
DC Characteristics					
TTL Input Level V_{IL}			0.8	Volts	Applies to transmitter inputs, SEL A, SEL B, SD and $\overline{\text{LB}}$
TTL Input Level V_{IH}	2.0			Volts	Applies to transmitter inputs, SEL A, SEL B, SD and $\overline{\text{LB}}$
High Level Voltage Output	+5.0		+15.0	Volts	$R_L = 3\text{k}\Omega$ to GND
Low Level Voltage Output	-15.0		-5.0	Volts	$R_L = 3\text{k}\Omega$ to GND
Open Circuit Output			+/-15	Volts	$R_L = \infty$
Short Circuit Current			+/-100	mA	$V_{OUT} = 0\text{V}$
Power Off Impedance	300			Ω	$V_{CC} = 0\text{V}$; $V_{OUT} = +/-2\text{V}$
AC Characteristics					
Transmission Rate	120			kbps	
Transition Time			1.56	μs	Rise/Fall time, +3V to -3V; -3V to +3V, $R_L = 3\text{k}\Omega$, $C_L = 2500\text{pF}$

SPECIFICATIONS (continued)

Limits are specified at $T_A = 25^\circ\text{C}$ and $V_{CC} = +5.0\text{V}$ unless otherwise noted.

PARAMETER	MIN.	TYP.	MAX.	UNITS	CONDITIONS
RS-232 DRIVER (continued)					
AC Characteristics					
Propagation Delay; t_{PHL}		2	4	μs	$R_L = 3\text{k}\Omega$, $C_L = 2500\text{pF}$, From 1.5V of T_{IN} to 50% of V_{OUT}
Propagation Delay; t_{PLH}		2	4	μs	$R_L = 3\text{k}\Omega$, $C_L = 2500\text{pF}$, From 1.5V of T_{IN} to 50% of V_{OUT}
Slew Rate		10	30	$\text{V}/\mu\text{s}$	$R_L = 3\text{k}\Omega$, $C_L = 50\text{pF}$; From +3V to -3V or -3V to +3V
RS-232 RECEIVER					
DC Characteristics					
TTL Output Level; V_{OL}			0.4	Volts	$I_{SINK} = 4\text{mA}$
TTL Output Level; V_{OH}	3.5			Volts	$I_{SOURCE} = -4\text{mA}$
Input High Threshold		2.1	3.0	Volts	
Input Low Threshold	0.8	1.6		Volts	
Input Voltage Range	-15		+15	Volts	
Input Impedance	3	5	7	$\text{k}\Omega$	$V_{IN} = +/-15\text{V}$
Hysteresis	0.2	0.5	1.0	Volts	$V_{CC} = +5\text{V}$
AC Characteristics					
Transmission Rate	120			kbps	
Transition Time		50		ns	Rise/Fall time, 10%-90%
Propagation Delay t_{PHL}		100	300	ns	From 50% of V_{IN} to 1.5V of R_{OUT}
Propagation Delay t_{PLH}		100	200	ns	
POWER REQUIREMENTS					
No Load Supply Current		19	25	mA	No Load; $V_{CC} = 5.0\text{V}$; $T_A = 25^\circ\text{C}$
Full Load Supply Current		90	120	mA	RS-232 drivers $R_L = 3\text{k}\Omega$ to GND, DC input RS-485 drivers $R_L = 54\Omega$ from A to B; DC input
Shutdown Supply Current		5	50	μA	$T_A = 25^\circ\text{C}$, $V_{CC} = 5.0\text{V}$

Note 1: Exceeding the maximum data rate may damage the device

TEST CIRCUITS

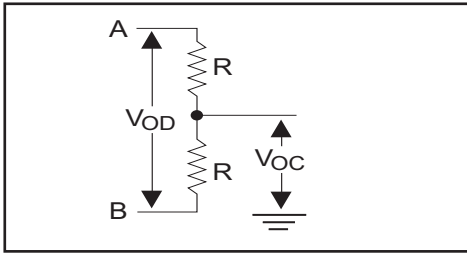

Figure 1. RS-485 Driver DC Test Load Circuit

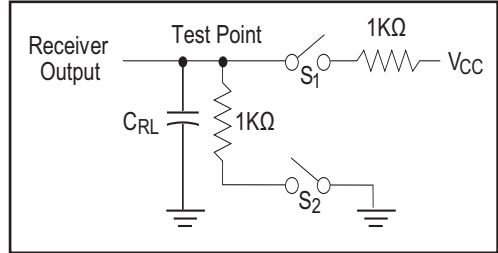

Figure 2. Receiver Timing Test Load Circuit

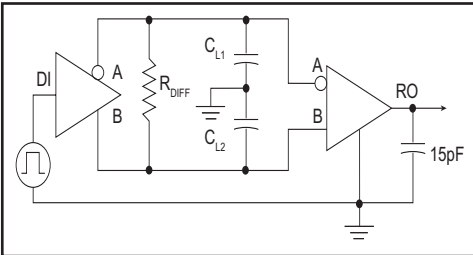

Figure 3. RS-485 Driver/Receiver Timing Test Circuit

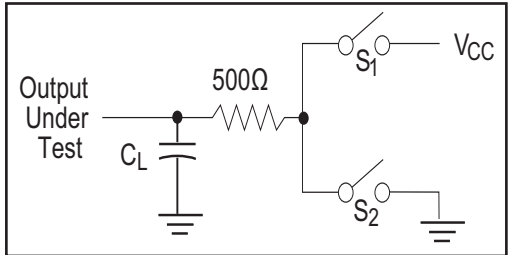

Figure 4. RS-485 Driver Timing Test Load #2 Circuit

SWITCHING WAVEFORMS

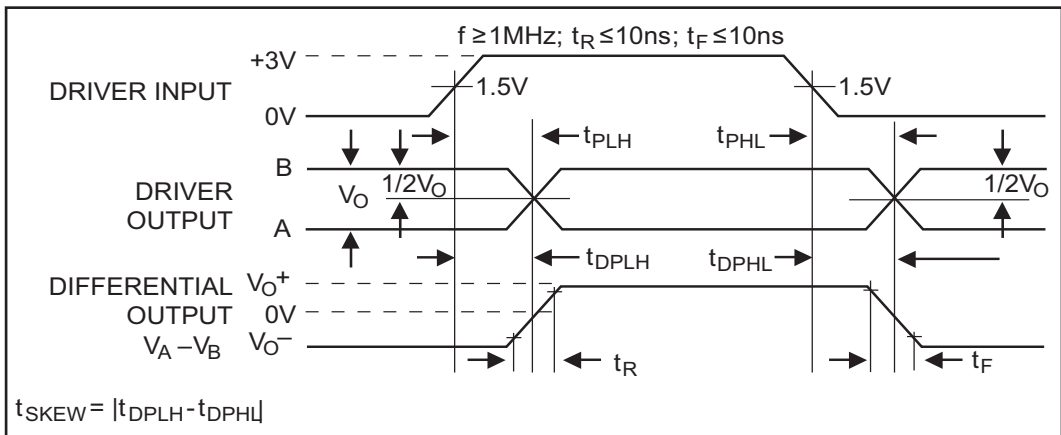

Figure 5. RS-485 Driver Propagation Delays

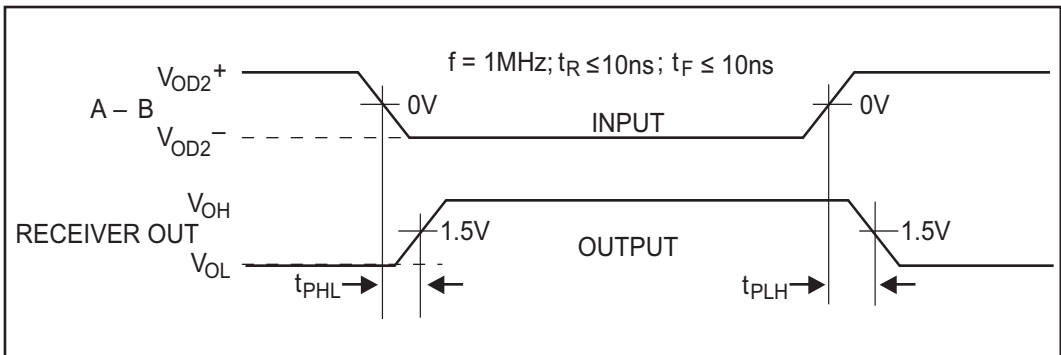

Figure 6. RS-485 Receiver Propagation Delays

The **SP332** is single chip device that can be configured via software for either RS-232, RS-485 or both interface modes at any time. The **SP332** is made up of three basic circuit elements, single-ended drivers and receivers, differential drivers and receivers and charge pump.

DIFFERENTIAL DRIVER/RECEIVER...

RS-485, RS-422 Drivers...

The differential drivers and receivers comply with the RS-485 and RS-422 standards. The driver circuits are able to drive a minimum of 1.5V when terminated with a 54Ω resistor across the two outputs. The typical propagation delay from driver input to output is 60ns. The driver outputs are current limited to less than 250mA, and can tolerate shorts to ground, or to any voltage within a +10V to -7V range with no damage.

RS-485, RS-422 Receivers...

The differential receivers of the **SP332** comply with the RS-485 and RS-422 standards. The input to the receiver is equipped with a common mode range of +12V to -7V. The input threshold over this range is a minimum of +/-200mV. The differential receivers can receive data up to 10Mbps. The typical propagation delay from the receiver input to output is 90ns.

SINGLE ENDED DRIVER / RECEIVER...

RS-232 (V.28) Drivers...

The single-ended drivers and receivers comply with the RS-232 and V.28 standards. The drivers are inverting transmitters which accept either TTL or CMOS inputs and output the RS-232 signals with an inverted sense relative to the input logic levels. Typically, the RS-232 driver output voltage swing is +/-9V with no load and is guaranteed to be greater than +/-5V under full load. The drivers rely on the V+ and V- voltages generated by the on-chip charge pump to maintain proper RS-232 output levels. With worst case load conditions of 3kΩ and 2500pF, the four RS-232 drivers can still maintain +/-5V output levels. The drivers can operate up to 120kbps; the propagation delay from input to output is typically 2μs.

RS-232 (V.28) Receivers...

The RS-232 receivers convert RS-232 input signals to inverted TTL signals. Each of the four receivers features 500mV of hysteresis margin to minimize the effects of noisy transmission lines. The inputs also have a 5kΩ resistor to ground, in an open circuit situation the input of the receiver will be forced low, committing the output to a logic high state. The input resistance will maintain 3kΩ to 7kΩ over a +/-15V range. The maximum operating voltage range for the receiver is +/-30V, under these conditions the input current to the receiver must be limited to less than 100mA. Due to the on-chip ESD protection circuitry, the receiver inputs will be clamped to +/-15V levels. The RS-232 receivers can operate up to 120kbps.

Charge-Pump

The charge pump is a **Exar**-patented design (U.S. 5,306,954) and uses a unique approach compared to older less efficient designs. The charge pump still requires four external capacitors, but uses a four-phase voltage shifting technique to attain symmetrical 10V power supplies. Figure 7(a) shows the waveform found on the positive side of capacitor C₂, and Figure 7(b) shows the negative side of capacitor C₂. There is a free-running oscillator that controls the four phases of the voltage shifting. A description of each phase follows.

Phase 1

—V_{SS} charge storage—During this phase of the clock cycle, the positive side of capacitors C₁ and C₂ are initially charged to +5V. C₁⁺ is then switched to ground and charge on C₁⁺ is transferred to C₂⁻. Since C₂⁺ is connected to +5V, the voltage potential across capacitor C₂ is now 10V.

Phase 2

—V_{SS} transfer—Phase two of the clock connects the negative terminal of C₂ to the V_{SS} storage capacitor and the positive terminal of C₂ to ground, and transfers the generated -10V to C₃⁻. Simultaneously, the positive side of capacitor C₁ is switched to +5V and the negative side is connected to ground.

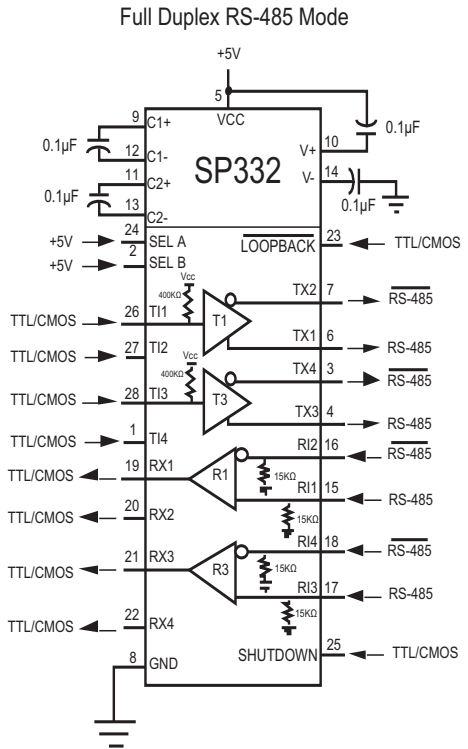
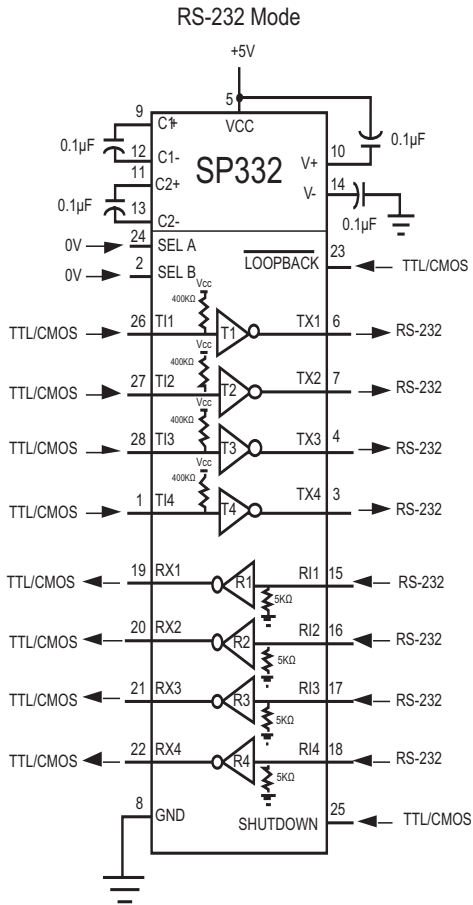

PINOUT

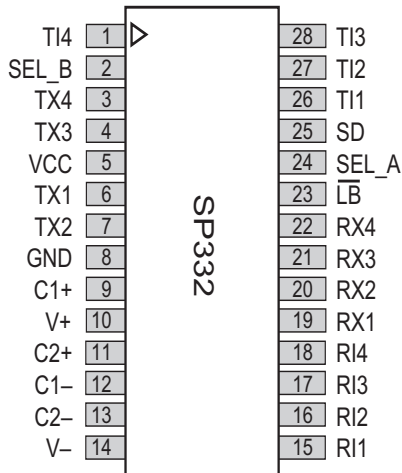

SP332 CONTROL LOGIC CONFIGURATION

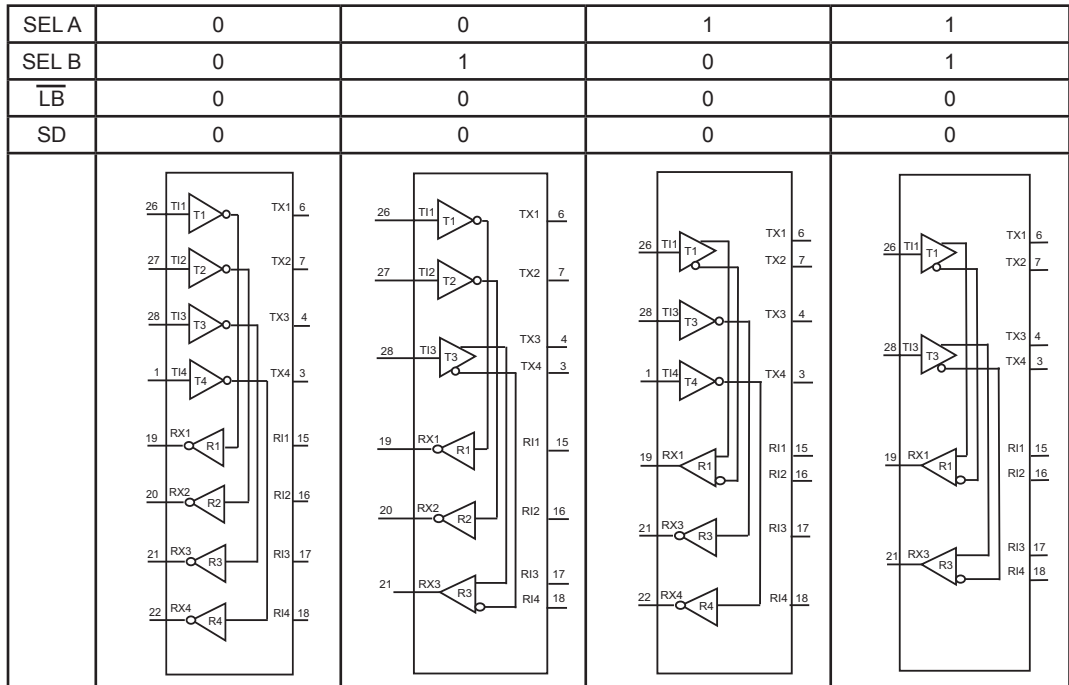
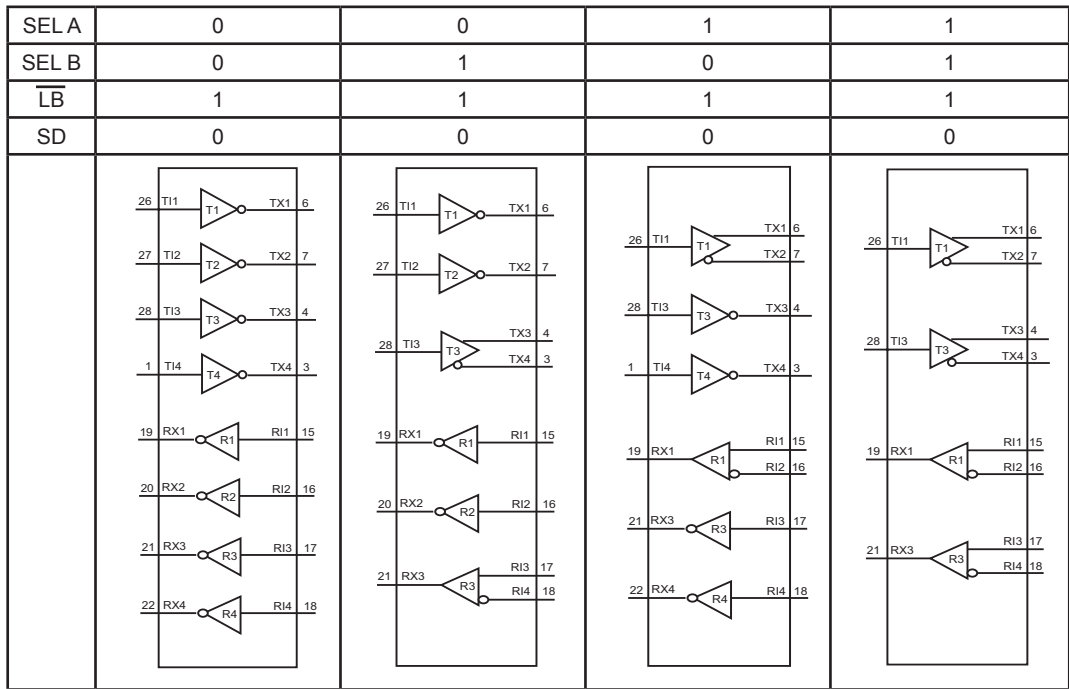

Receiver Inputs are inactive in Loopback Mode ($\overline{\text{LOOPBACK}} = 0$)
 Driver Outputs are Tri-stated in Loopback Mode ($\overline{\text{LOOPBACK}} = 0$)
 Unused Outputs are Tri-stated

REVISION HISTORY			
REV.	DESCRIPTION	DATE	APP'D
A	DRAWING ORIENTATION	04/24/06	JL
B	CHANGE DRAWING LOGO AND COMPANY NAME	11/28/07	JL

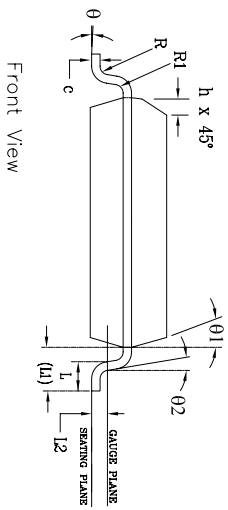
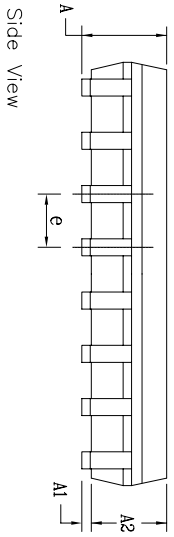
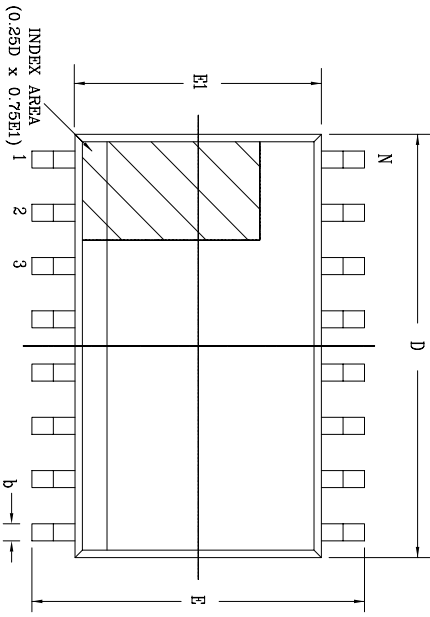

SYMBOLS	28 Pin SOICW JEDEC MS-013 Variation AE		DIMENSIONS IN MM (Control Unit)			DIMENSIONS IN INCH (Reference Unit)		
	MIN	NOM	MAX	MIN	NOM	MAX		
A	2.35	—	2.65	0.093	—	0.104		
A1	0.10	—	0.30	0.004	—	0.012		
A2	2.05	—	2.55	0.081	—	0.100		
b	0.31	—	0.51	0.012	—	0.020		
c	0.20	—	0.33	0.008	—	0.013		
E	10.30	BSC	—	—	—	0.406 BSC		
E1	7.50	BSC	—	—	—	0.295 BSC		
e	1.27	BSC	—	—	—	0.050 BSC		
h	0.25	—	0.75	0.010	—	0.030		
L	0.40	—	1.27	0.016	—	0.050		
L1	1.40	REF	—	—	—	0.055 REF		
L2	0.25	BSC	—	—	—	0.010 BSC		
R	0.07	—	—	0.003	—	—		
R1	0.07	—	—	0.003	—	—		
θ	0°	—	8°	0°	—	8°		
θ1	5°	—	15°	5°	—	15°		
θ2	0°	—	—	0°	—	—		
D	17.90	BSC	—	—	—	0.705 BSC		
N	28	—	—	—	—	28		

		EXAR CORPORATION	
Packaging Approver:		Drawing No: 28 PIN SOICW PACKAGE OUTLINE	
By: JL	Date: 11/28/07	Revision: B	Sheet: 1 OF 1

ORDERING INFORMATION

Model	Temperature Range	Package Types
SP332CT-L.....	0°C to +70°C.....	28-pin WSOIC
SP332CT-L/TR.....	0°C to +70°C.....	28-pin WSOIC
SP332ET-L.....	-40°C to +85°C.....	28-pin WSOIC
SP332ET-L/TR.....	-40°C to +85°C.....	28-pin WSOIC

Note: /TR = Tape and Reel

REVISION HISTORY

DATE	REVISION	DESCRIPTION
9617RO	-	Legacy Sipex Datasheet
01/26/10	1.0.0	Convert to Exar Format. Add Revision History table. Change revision to 1.0.0. Add Note 1 and change maximum RS-485 data rate at +85C. Update ABS Max Rating table.

Notice

EXAR Corporation reserves the right to make changes to any products contained in this publication in order to improve design, performance or reliability. EXAR Corporation assumes no representation that the circuits are free of patent infringement. Charts and schedules contained herein are only for illustration purposes and may vary depending upon a user's specific application. While the information in this publication has been carefully checked; no responsibility, however, is assumed for inaccuracies.

EXAR Corporation does not recommend the use of any of its products in life support applications where the failure or malfunction of the product can reasonably be expected to cause failure of the life support system or to significantly affect its safety or effectiveness. Products are not authorized for use in such applications unless EXAR Corporation receives, in writing, assurances to its satisfaction that: (a) the risk of injury or damage has been minimized ; (b) the user assumes all such risks; (c) potential liability of EXAR Corporation is adequately protected under the circumstances.

Copyright 2010 EXAR Corporation

Datasheet January 2010

Send your Interface technical inquiry with technical details to: uarttechsupport@exar.com

Reproduction, in part or whole, without the prior written consent of EXAR Corporation is prohibited.