



Chipsmall Limited consists of a professional team with an average of over 10 year of expertise in the distribution of electronic components. Based in Hongkong, we have already established firm and mutual-benefit business relationships with customers from,Europe,America and south Asia,supplying obsolete and hard-to-find components to meet their specific needs.

With the principle of “Quality Parts,Customers Priority,Honest Operation,and Considerate Service”,our business mainly focus on the distribution of electronic components. Line cards we deal with include Microchip,ALPS,ROHM,Xilinx,Pulse,ON,Everlight and Freescale. Main products comprise IC,Modules,Potentiometer,IC Socket,Relay,Connector.Our parts cover such applications as commercial,industrial, and automotives areas.

We are looking forward to setting up business relationship with you and hope to provide you with the best service and solution. Let us make a better world for our industry!



## Contact us

Tel: +86-755-8981 8866 Fax: +86-755-8427 6832

Email & Skype: info@chipsmall.com Web: www.chipsmall.com

Address: A1208, Overseas Decoration Building, #122 Zhenhua RD., Futian, Shenzhen, China





# SP6127, 2A Evaluation Board Manual

- Easy Evaluation for the SP6127EK1 12V Input, 0 to 2A Output Non-Synchronous Buck Converter
- Precision 0.60V  $\pm$ 1% High-Accuracy Reference.
- Small form factor
- Feature Rich: Single supply operation, Over-current protection with auto-restart, on/off function, Preset internal soft start, Type-II internal compensation

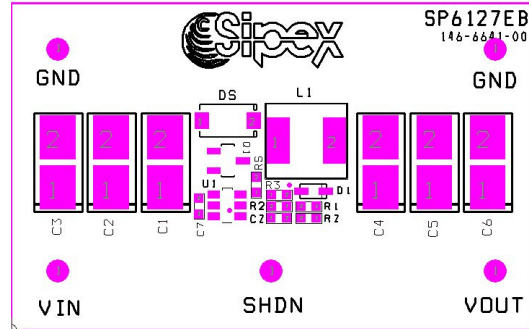

## SP6127EB SCHEMATIC

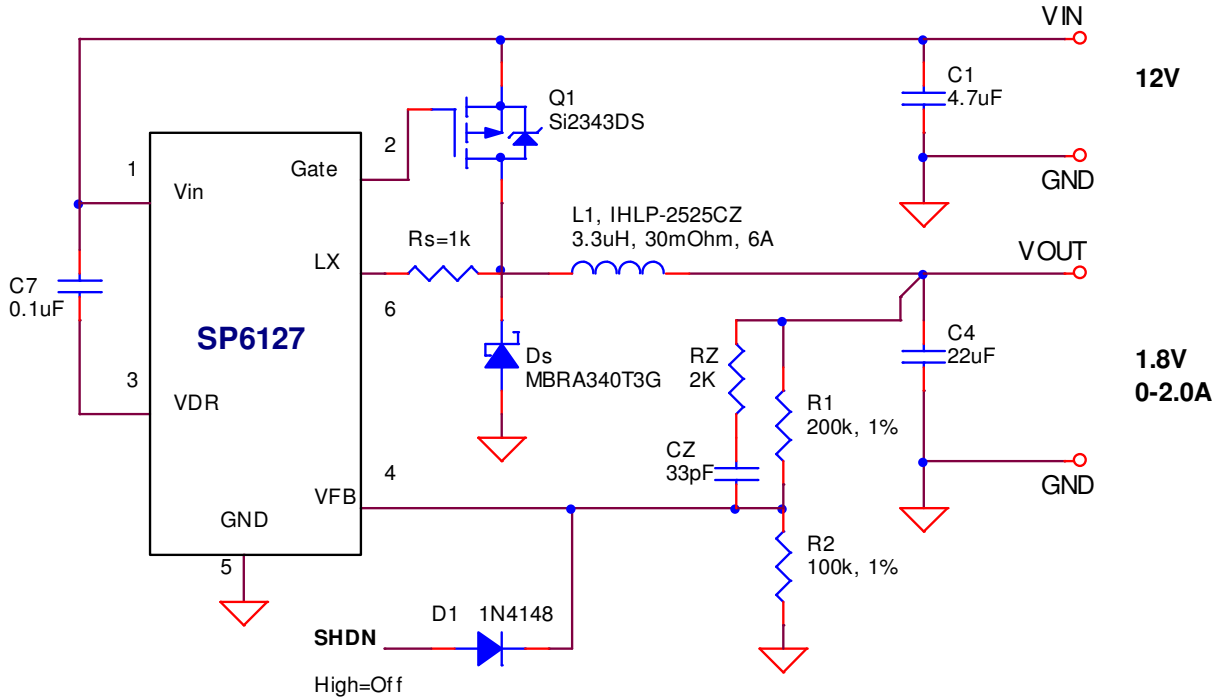

## USING THE EVALUATION BOARD

### 1) Powering Up the SP6127EB Circuit

Connect the SP6127 Evaluation Board to an external +12V power supply. Connect with short leads directly to the “VIN” and “GND” posts. Connect a Load between the “VOUT” and “GND” posts, again using short leads to minimize inductance and voltage drop.

### 2) Measuring Output Load Characteristics

It's best to GND reference scope and digital meters using the Star GND post near the output of the board. VOUT ripple can best be seen touching probe tip to the pad for COUT and scope GND collar touching Star GND post – avoid a GND lead on the scope which will increase noise pickup.

### 3) Using the Evaluation Board with Different Output Voltages

While the SP6127 Evaluation Board has been tested and delivered with the output set to 1.80V, by simply changing one resistor, R2, the SP6127 can be set to other output voltages. The relationship in the following formula is based on a voltage divider from the output to the feedback pin FB, which is set to an internal reference voltage of 0.60V. Standard 1% metal film resistors of surface mount size 0603 are recommended.

$$R2 = \frac{R1}{\left(\frac{Vout}{Vref} - 1\right)}$$

Where R1 = 200kΩ. For Vout = 0.60V setting, simply remove R2 from the board.

Note that since the SP6127 Evaluation Board design was optimized for 12V down conversion to 1.80V, changes of output voltage and/or input voltage will alter performance from the data given in the Power Supply Data section.

### Using the SHDN (ON/OFF function)

Feedback pin serves a dual role of ON/OFF control. The MOSFET driver is disabled when a voltage greater than 1V is applied at FB pin. Maximum voltage rating of this pin is 5.5V. The controlling signal should be applied through a small signal diode as shown on page 1. *Note that under no-load condition an optional 10kOhm bleeding resistor across the output helps keep the output capacitor discharged.*

## POWER SUPPLY DATA

The SP6127EB is designed with an accurate 2% reference over line, load and temperature. Figure 1 data shows a typical SP6127 Evaluation Board efficiency plot, with efficiencies to 75% and output currents to 2A. SP6127 Load Regulation in Figure 2 shows very little change in output voltage from no load to 2A load. Figures 3 and 4 show the transient response of the SP6127 and overcurrent shutdown. Figures 5 and 6 show a controlled start-up with no load and 2A load when power is applied where the input current rises smoothly as the soft-start ramp increases. Figures 7 and 8 show the output ripple under no load and 2A load.

# Typical Performance Characteristics

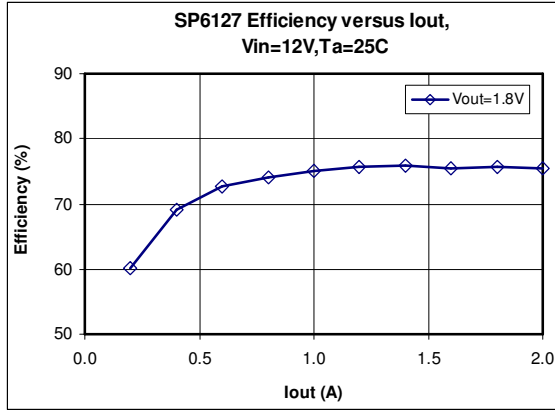

Figure 1- Efficiency

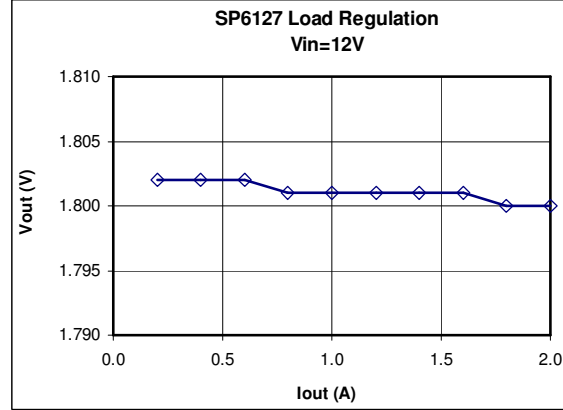

Figure 2- Load regulation

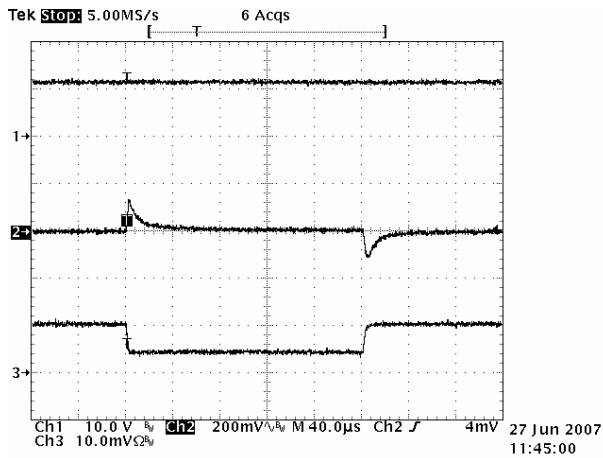

Figure 3- Step load 1-2A, ch1: Vin  
ch2: Vout, ch3: Iout

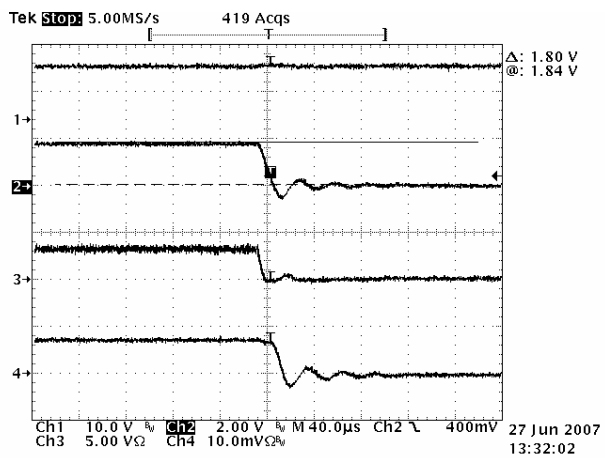

Figure 4- OCP shutdown, ch1: Vin  
ch2: Vout, ch3: Inductor current, ch4: I<sub>o</sub>

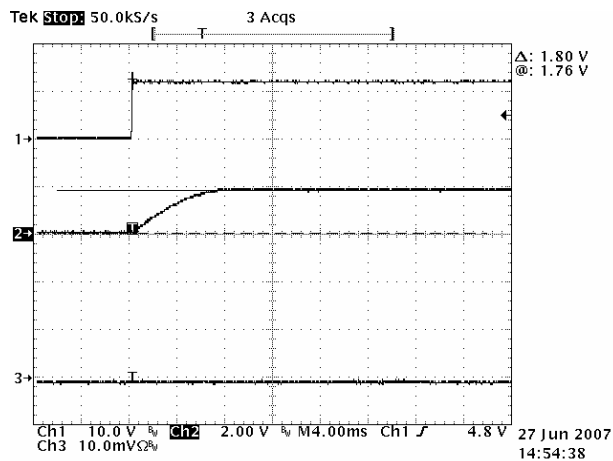

Figure 5- Startup no load, ch1: Vin  
ch2: Vout, ch3: Iout

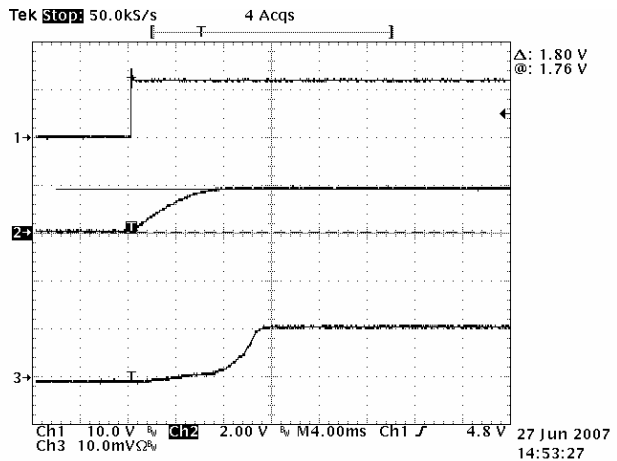

Figure 6- Startup 2A, ch1: Vin  
ch2: Vout, ch3: Iout

# Typical Performance Characteristics

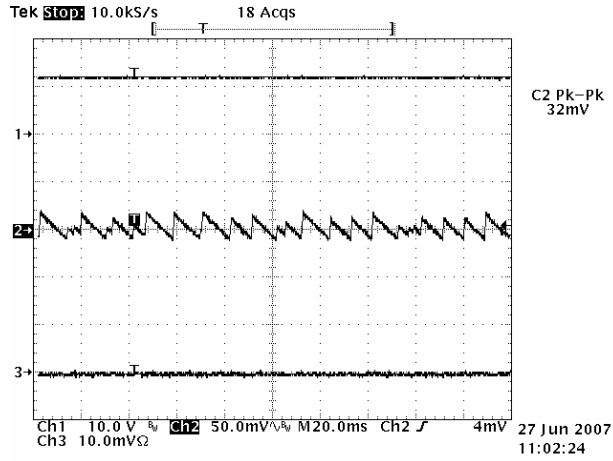

Figure 7- Output ripple at 0A is 32mV, ch1: Vin, ch2: Vout, ch3: Iout

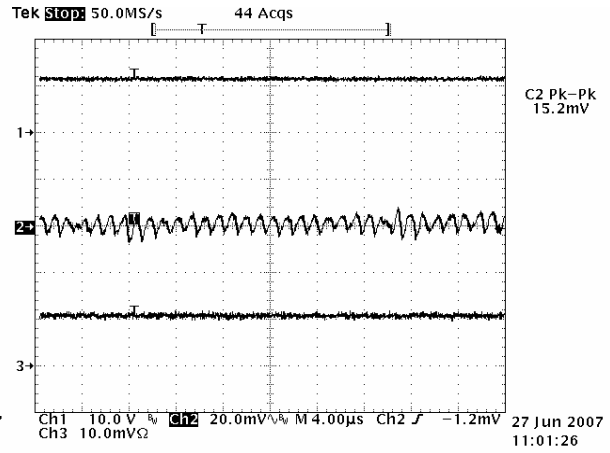

Figure 8- Output ripple at 2A is 15mV, ch1: Vin, ch2: Vout, ch3: Iout

## LOOP COMPENSATION

The SP6127 includes Type-II internal compensation components for loop compensation. External compensation components are not required for systems with tantalum or aluminum electrolytic output capacitors with sufficiently high ESR. Use the condition below as a guideline to determine whether or not the internal compensation is sufficient for your design.

Type-II internal compensation is sufficient if the following condition is met:

$$f_{ESRZERO} < f_{DBPOLE} \quad \dots\dots\dots (1)$$

where:

$$f_{ESRZERO} = \frac{1}{2\pi \cdot R_{ESR} \cdot C_{OUT}} \quad \dots\dots\dots (2)$$

$$f_{DBPOLE} = \frac{1}{2\pi \cdot \sqrt{L} \cdot C_{OUT}} \quad \dots\dots\dots (3)$$

### Creating a Type-III compensation Network

The above condition requires the ESR zero to be at a lower frequency than the double-pole from the LC filter. If this condition is not met, Type-III compensation should be used and can be accomplished by placing a series RC combination in parallel with R1 as shown below. The value of CZ can be calculated as follows and RZ selected from table 1.

$$CZ = \frac{\sqrt{L \cdot C}}{1.25 \times R1} \quad \dots\dots\dots (4)$$

$f_{ESRZERO}/f_{DBPOLE}$	RZ
1X	50K
2X	40K
3X	30K
5X	10K
>= 10X	2K

Table1- Selection of RZ

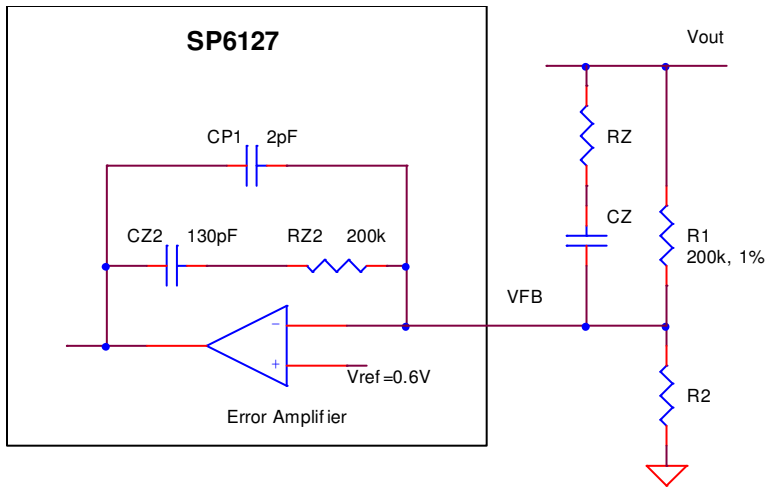

Figure 9- RZ and CZ in conjunction with internal compensation components form a Type-III compensation

### Loop Compensation for the SP6127EB

$L = 3.3\mu\text{H}$ ,  $C = 22\mu\text{F}/5\text{m}\Omega$  ceramic capacitor

From equation (2)  $f_{\text{ESRZERO}} = 1.45\text{MHz}$ . From equation (3)  $f_{\text{DBPOLE}} = 18.7\text{kHz}$ . Since the condition specified in (1) is not met, Type-III compensation has to be used by adding external components RZ and CZ. Using equation (4) CZ is calculated 34pF (use 33pF). Following the guideline given in table 1, a 2k $\Omega$  RZ was used.

# PCB LAYOUT DRAWINGS

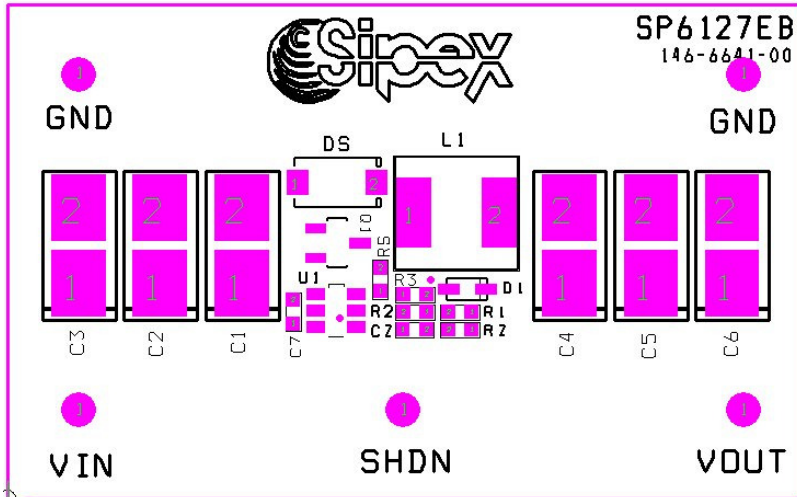

Figure 10. SP6127EB Component Placement

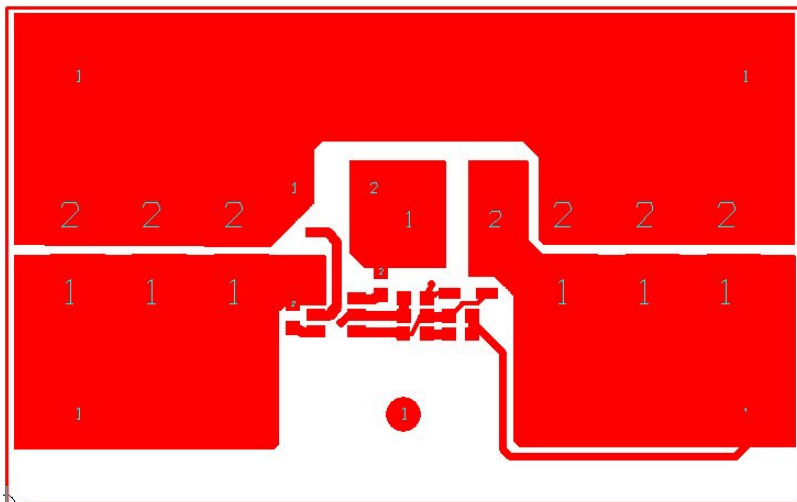

Figure 11. SP6127EB PCB Layout Top Side



Figure 12. SP6127EB PCB Layout Bottom Side



Line No.	Ref. Des.	Qty.	Manuf.	Manuf. Part Number	Layout Size	Component	Vendor Phone Number
1	PCB	1	Sipex	146-6641-00	1.175"x1.934"	SP6127EB	408-934-7500
2	U1	1	Sipex	SP6127EK1	TSOT-6	Non-synchronous Buck Controller	408-934-7500
3	Q1	1	Vishay Semi	Si2343DS	SOT-23	PFET, 30V, 86mOhm	402-563-6866
4	DS	1	On Semi	MBRA340T3	SMA	Schotkky, 40V, 3A	602-244-6600
5	L1	1	Vishay	IHLP2525CZ	6.86x6.47mm	3.3uH Coil 6A 30mOhm	914-347-2474
6	D1	1	MCC	1N4148WX	SOD323	Fast Switching Diode 500mW	818-701-4933
7	C1	1	MURATA	GRM21BR61E475K	0805	4.7 uF Ceramic X5R 25V	770-436-1300
8	C6	1	MURATA	GRM21BR60J226M	0805	22uF Ceramic X5R 6.3V	770-436-1300
9	C7	1	MURATA	GRM18ER61E104K	0603	0.1uF Ceramic X5R	770-436-1300
10	CZ	1	MURATA	GRM1885C1H330JA	0603	33pF Ceramic C0G 50V	770-436-1300
11	R1	1	VISHAY/DALE	CRCW0603200K	0603	200k	402-563-6866
12	R2	1	VISHAY/DALE	CRCW060344K2	0603	100k	402-563-6866
13	RZ	1	VISHAY/DALE	CRCW06037K15	0603	2.00k	402-563-6866
14	VIN, VOUT, GND, GND, SHDN	5	Vector Electronic	K24C/M	.042 Dia	Test Point Post	800-344-4539

Table 2- SP6127EB List of Materials

INDUCTORS - SURFACE MOUNT								
Inductance (uH)	Manufacturer/Part No.	Inductor Specification				Inductor Type	Manufacturer Website	
		DCR mOhms	Isat (A)	Size LxW(mm)   Ht.(mm)				
3.3	VISHAY	30.0	13.50	6.47x6.86	3.00	Shielded	<a href="http://www.vishay.com">www.vishay.com</a>	
CAPACITORS - SURFACE MOUNT								
Capacitance (uF)	Manufacturer/Part No.	Capacitor Specification					Capacitor Type	Manufacturer Website
		ESR ohms (max)	Ripple Current (A) @20C Delta	Size LxW(mm)   Ht.(mm)		Voltage (V)		
4.7	GRM21BR61E475K	0.005	2.20	2x1.25	1.25	25.0	X5R Ceramic <a href="http://www.murata.com">www.murata.com</a>	
22	GRM21BR60J226M	0.005	3.50	2x1.25	1.25	6.3	X5R Ceramic <a href="http://www.murata.com">www.murata.com</a>	
MOSFETS - SURFACE MOUNT								
MOSFET	Manufacturer/Part No.	MOSFET Specification					Foot Print	Manufacturer Website
		RDS(on) ohms (max)	ID Current (A)	Qg nC (Typ)   nC (Max)		Voltage (V)		
P-Ch	VISHAY Si2343DS	86.00	3.1	14.0	21.0	30.0	SOT-23 <a href="http://www.vishay.com">www.vishay.com</a>	

Table 3- SP6127EB Suggested Components and Vendor Lists

### ORDERING INFORMATION

Model	Temperature Range	Package Type
SP6127EB .....	- 40°C to +125°C.....	SP6127 Evaluation Board
SP6127EK1.....	- 40°C to +125°C.....	6-pin TSOT-6