



Chipsmall Limited consists of a professional team with an average of over 10 year of expertise in the distribution of electronic components. Based in Hongkong, we have already established firm and mutual-benefit business relationships with customers from,Europe,America and south Asia,supplying obsolete and hard-to-find components to meet their specific needs.

With the principle of “Quality Parts,Customers Priority,Honest Operation,and Considerate Service”,our business mainly focus on the distribution of electronic components. Line cards we deal with include Microchip,ALPS,ROHM,Xilinx,Pulse,ON,Everlight and Freescale. Main products comprise IC,Modules,Potentiometer,IC Socket,Relay,Connector.Our parts cover such applications as commercial,industrial, and automotives areas.

We are looking forward to setting up business relationship with you and hope to provide you with the best service and solution. Let us make a better world for our industry!



Contact us

Tel: +86-755-8981 8866 Fax: +86-755-8427 6832

Email & Skype: info@chipsmall.com Web: www.chipsmall.com

Address: A1208, Overseas Decoration Building, #122 Zhenhua RD., Futian, Shenzhen, China





SP6650 Evaluation Board Manual

- High efficiency synchronous step-down converter with up to 95% efficiency
- Ideal for cellular telephones, wireless modems, PDAs, digital cameras
- Programmable inductor peak current limit, 2.7V-6.5V input voltage range
- MSOP package & SMT components for small, low profile power supply
- Easy evaluation for different distributed power systems and battery-powered portable equipment

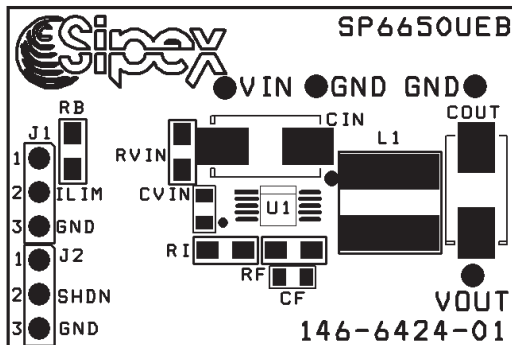

DESCRIPTION

The **SP6650 Evaluation Board** is designed to help the user evaluate the performance of the SP6650 for use as a single Li-Ion battery input to +5V output DC-DC Converter. The SP6650 operates from 2.7V to 6.5V input, with the highest efficiency in the range 3.0V to 4.2V where the Li-Ion battery has the most energy. The SP6650UEB evaluation board is a complete power supply circuit to provide ease of evaluation for the DC/DC Converter performance.

The evaluation board is a completely assembled and tested surface mount board which provides easy probe access points to all SP6650 inputs and outputs so that the user can quickly connect and measure electrical characteristics and waveforms.

The next two sections describe the SP6650 board layout and using the SP6650 evaluation boards. A table of SP6650 pin assignments is also included with details on input/output pin function. A SP6650 evaluation board list of materials table is provided with some manufacturers part numbers to use as a reference. Finally, a schematic and drawings of the PC layout are included as a design-in tool for the user of the SP6650.

BOARD SCHEMATIC AND LAYOUT

The SP6650 Evaluation Board has been designed for easy and convenient access to all Inputs and Outputs of the SP6650 device under test. Position the board with the silkscreen lettering upright, (also see the drawing on the front page of this manual) and you will see the SP6650 MSOP, labeled U1 in the center of the board, and surrounding it the capacitors C_{IN} , C_{VIN} , CF , C_{OUT} and resistors forming the switched DC-DC Converter circuit.

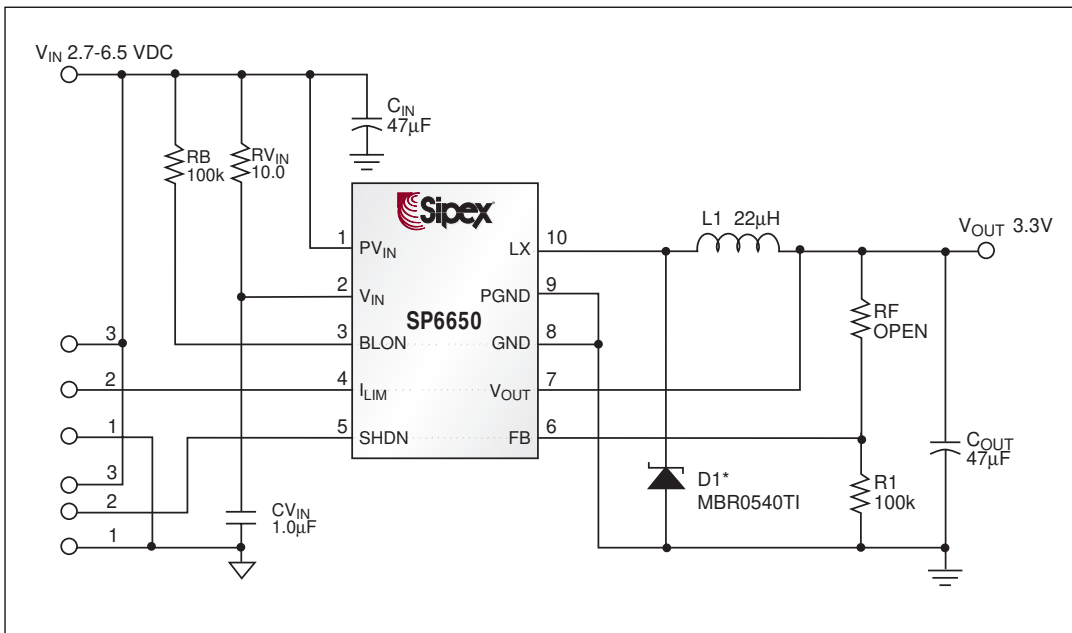

Figure 1. SP6650 Evaluation Board Schematic

The SP6650 Evaluation Board provides convenient test points to connect the input to Power Supply or Li-Ion Battery. The Input and Output connections are made with raised female pin receptacles which can accommodate easy-hook connection leads for power and meter connections, as well as scope probe hooks and grounds for waveform measurements.

USING THE EVALUATION BOARD

1) Powering Up the SP6650 Circuit

The SP6650 Evaluation Board can be powered from a single Li-Ion battery or a +2.7 to +6.5V power supply. Connect with short leads directly to the “V_{IN}” and “GND” posts. Note the SP6650 will remain in “shutdown” until pin 2 of the Jumper J2 is applied to the GND.

2) I_{LIM} Programming

Connect pin 4 of the SP6650 to V_{IN} for 0.8 A peak Inductor current limit (pins 2,3 of the Jumper J2).

Connect pin 4 of the SP6650 to GND for 0.35 A peak Inductor current limit (pins 1,2 of the Jumper J2).

3) V_{OUT} Programming

To control the output voltage externally connect the appropriate resistors (Table 1)

From pin 6 SP6650 FB to V_{OUT} and to the GND.

Tie Pin 6 FB to the 100k resistor or to the GND and controller will use the internal network for a preset output Voltage of 3.3V. For V_{OUT} different from shown in the Table 1, use equation:

$$R_F = \left(\frac{V_{OUT}}{1.25} - 1 \right) R_1$$

(For V_{OUT} > 3.3V, R_F = 50k recommended)

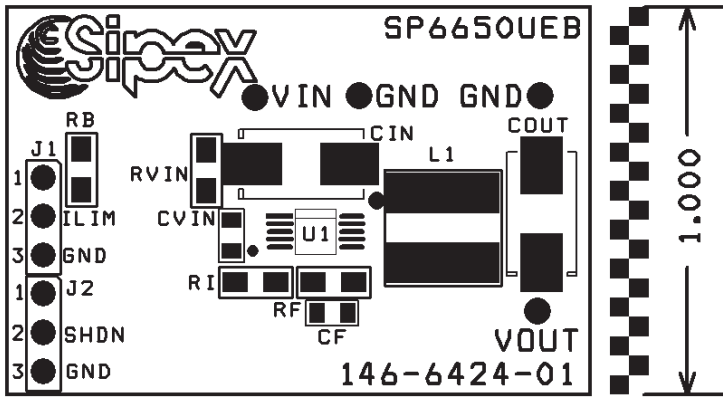

Figure 2: SP6650UEB Component Placement

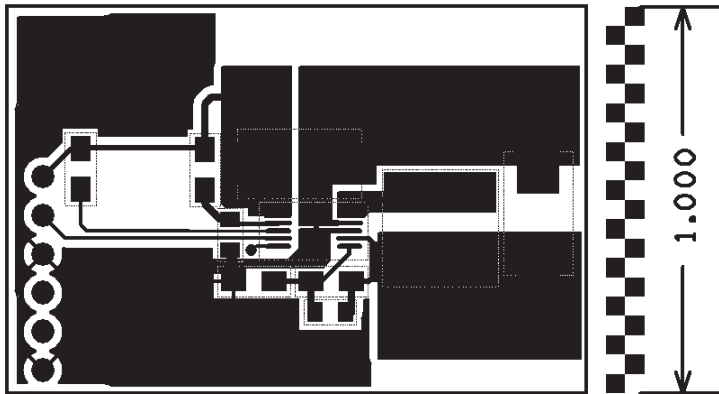

Figure 3: SP6650UEB PC layout Top Side

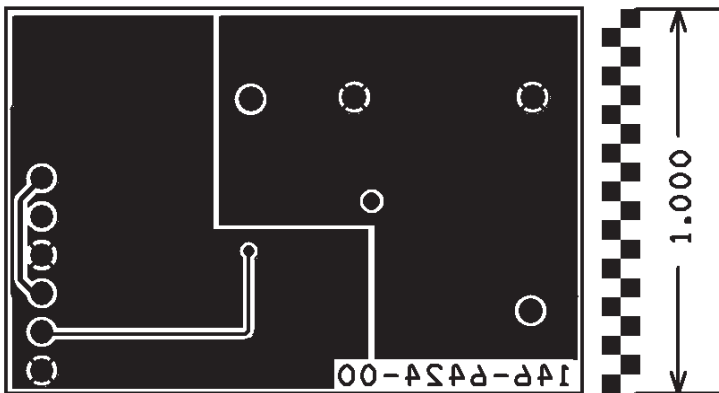

Figure 4: SP6650UEB PC Layout Bottom Side

TABLE 1: SP6650UEB LIST OF MATERIALS

Component	V_{OUT} = 3.3V, Int FB	V_{OUT} = 2.5V, Ext FB	V_{OUT} = 1.25V, Ext FB
L1	22μH,CDRH6D28 Sumida	22μH,CDRH6D28 Sumida	22μH,CDRH6D28 Sumida
C _{IN}	47μF, AVX TPSD	47μF, AVX TPSD	47μF, AVX TPSD
C _{OUT}	47μF, AVX TPSD	47μF, AVX TPSD	47μF, AVX TPSD
RB	100k 5%	100k 5%	100k 5%
RV _{IN}	10Ω 5%	10Ω 5%	10Ω 5%
CV _{IN}	1μF ceramic	1μF ceramic	1μF ceramic
RI	100k 1%	100k 1%	100k 1%
RF	open	100k 1%	short
CF	open	470pF ceramic	open
U1	SP6650	SP6650	SP6650

PIN DESCRIPTION

PIN NUMBER	PIN NAME	DESCRIPTION
1	PV_{IN}	Input voltage power pin. Inductor charging current passes through this pin.
2	V_{IN}	Internal supply voltage. Control circuitry powered from this pin.
3	BLON	Open drain battery low output. V_{IN} below battery low threshold pulls this node to ground. V_{IN} above threshold, this node is open.
4	I_{LIM}	Inductor current limit programming pin. Tie pin to V_{IN} for 0.8A peak inductor current limit. Tie pin to ground for 0.4A peak inductor current limit. TTL input threshold.
5	SHDN	Shutdown control input. Tie to V_{IN} for normal operation, tie to ground for shutdown. TTL input threshold.
6	FB	External feedback network input connection. Connect a resistor from FB to ground and FB to V_{OUT} to control the output voltage externally. This pin regulates to the internal bandgap reference voltage of 1.25V. Tie FB to ground to use the internal divider for a preset output voltage of 3.3V.
7	V_{OUT}	Output voltage sense pin. Used for internal feedback divider and timing circuit.
8	GND	Internal ground pin. Control circuitry returns current to this pin.
9	PGND	Power ground pin. Synchronous rectifier current returns through this pin.
10	LX	Inductor switching node. Inductor tied between this pin and the output capacitor to create regulated output voltage.

ORDERING INFORMATION

Part Number	Temperature Range	Package
SP6650UEB		SP6650 Evaluation Board
SP6650EU	-40°C to +85°C	10-pin MSOP



SIGNAL PROCESSING EXCELLENCE

Sipex Corporation

Headquarters and Sales Office

22 Linnell Circle
Billerica, MA 01821
TEL: (978) 667-8700
FAX: (978) 670-9001
e-mail: sales@sipex.com

Sales Office

233 South Hillview Drive
Milpitas, CA 95035
TEL: (408) 934-7500
FAX: (408) 935-7600

Sipex Corporation reserves the right to make changes to any products described herein. Sipex does not assume any liability arising out of the application or use of any product or circuit described herein; neither does it convey any license under its patent rights nor the rights of others.